

TUBELITE®

DEPENDABLE

LEADERS IN ECO-EFFICIENT STOREFRONT,
CURTAINWALL AND ENTRANCE SYSTEMS

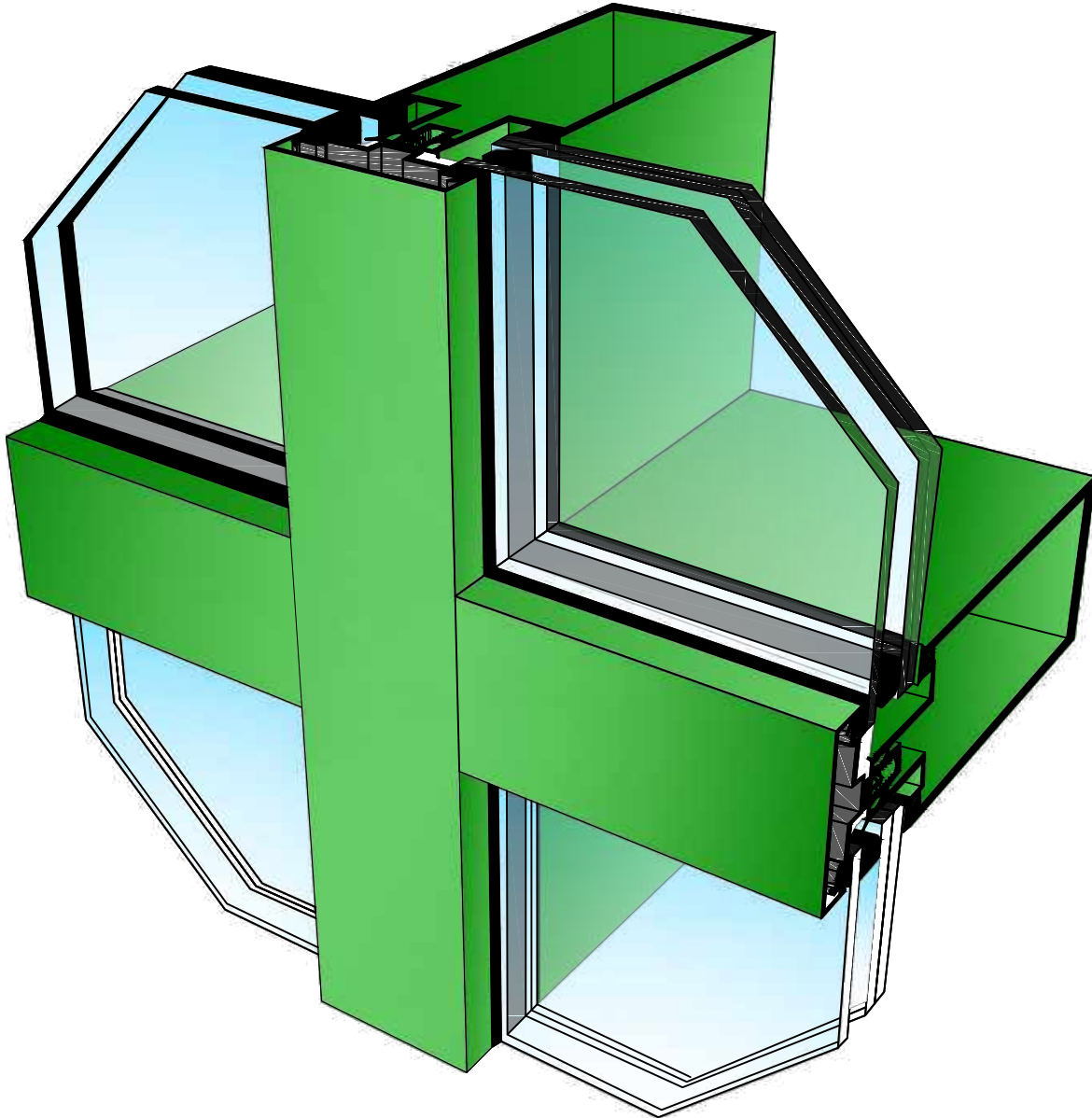

400 SERIES

HURRICANE RESISTANT CURTAIN WALL

INSTALLATION INSTRUCTIONS

3056 Walker Ridge Dr. NW, Suite G • Walker, MI 49544 • 800-866-2227

TUBELITE®

DEPENDABLE

*LEADERS IN ECO-EFFICIENT STOREFRONT,
CURTAINWALL AND ENTRANCE SYSTEMS*

TABLE OF CONTENTS

GENERAL CONSTRUCTION NOTES 4-5

QUICK REFERENCE CHECKLIST 5

PARTS LIST 6-9

ELEVATION TYPES and DETAILS 10-16

FRAME FABRICATION

- Step 1 Determine Frame Size 17
- Step 2 Cut Material to Length 18
- Step 3 Drill Verticals for Shear Blocks 19
- Step 4 Drill Horizontals for Shear Block Attachment 20
- Step 5 Fabricate Pressure Bars 21
- Step 6 Fabricate Weep Slots in Face Covers 22
- Step 7 Notch Head & Sill for Anchor Clearance 22
- Step 8 Fabricate Perimeter Anchor 23-24
- Step 9 Install Steel Reinforcement as Required 25
- Step 10 Fasten Shear Clip to Vertical..... 26
- Step 11 Install Head and Sill 'F' and 'T' Anchors 27

FRAME INSTALLATION

- Step 12 Installing Vertical Mullions 28
- Step 13 Splice Sleeve Installation 29
- Step 14 Attach Horizontals to Shear Blocks 30-31
- Step 15 Install Water Dams 32
- Step 16 Apply Perimeter Seal to Installation 33

GLAZING

- Step 17 Glazing Preparation 34
- Step 18 Installing Gaskets and Spacers 34-35
- Step 19 Installing Glass 36-38
- Step 20 Install Pressure Plates and Face Covers 39-46

ENTRANCE FRAMING..... 47-48

REGLAZING 49

CORNER CONDITIONS

- Outside Corner Exploded View 50

GENERAL CONSTRUCTION NOTES

1. These instructions cover typical product application, fabrication, installation and standard conditions and are general in nature. They provide useful guidelines, but the final shop drawings may include additional details specific to the project. Any conflict or discrepancies must be clarified prior to execution.
2. Materials stored at the job site must be kept in a safe protected from possible damage by other trades. Stack with adequate separation so materials will not rub together and store off the ground. Cardboard or paper wrapped materials must be kept dry. Check arriving materials for quality and keep a record of where various materials are stored.
3. All field welding must be done in accordance with AISC guidelines. All aluminum and glass should be shielded from field welding to avoid damage from weld splatter. Results will be unsightly and may be structurally unsound. Advise general contractor and trades accordingly.
4. Coordinate protection of installed work with general contractor and/or other trades.
5. Coordinate sequence of other trades which affect framing installation with the general contractor (e.g. fire proofing, back up walls, partitions, ceilings, mechanical ducts, HVAC, etc).
6. General contractor should furnish and guarantee bench marks, offset lines and opening dimensions. These items should be checked for accuracy before proceeding with installation because this could constitute acceptance of adjacent substrate construction by others.
7. Isolate all aluminum to be placed directly in contact with masonry or other incompatible materials with a heavy coat of zinc chromate bituminous paint. Fasteners attaching framing to building structure are typically not provided by Tubelite.
8. Sealant selection is the responsibility of the erector, installer and/or glazing contractor and must be approved by the sealant manufacturer with regard to application and compatibility for its intended use. All sealants must be used in strict accordance with the manufacturer's instructions and applied only by trained personnel to surfaces that have been properly prepared.
9. Sealant must be compatible with all materials with which they have contact, including other sealant surfaces. Consult the sealant manufacturer for recommendations relative to live, compatibility cleaning of substrate, priming, tooling/adhesion, etc. Recommend sealant manufacturer perform adhesion "pull test" at "wet" glazing for quality assurance.
10. Drainage gutters and weep holes must be kept clean at all times. Tubelite will not accept responsibility for improper drainage as a result of clogged gutters and weep holes.
11. This product requires clearances at the head, sill and jambs to allow for thermal expansions and contraction as well as construction tolerances. Refer to final distribution drawings for joint sizes. Joints smaller than 1/2" may be subject to failure. Consult the sealant manufacturer for proper sizing of joints.
12. All framing members, entrances and other materials are to be installed plumb, level and with regard to established bench mark, column center lines or other working points established by the general contractor and checked by the erector, installer and/or glazing contractor.
13. After sealant is set and a representative amount of the wall has been glazed (500 square feet or more), Tubelite recommends a water hose test to check installation. On large projects, a hose test should be repeated during glazing operation. This testing should be conducted in accordance with AAMA 501.2 specifications.
14. Cleaning of exposed aluminum surfaces should be done per AAMA recommendations.
15. Care must be taken when assembling aluminum framing components. Over tightening any fastener may cause stripping or fastener failure. Tubelite recommends the use of drill motors with clutches engaged to provide satisfactory tightening of the screw while preventing over torque. The use of impact drill motors is not recommended due to the absence of a clutch device.
16. Check www.tubeliteinc.com for any installation updates

GENERAL CONSTRUCTION NOTES

QUICK REFERENCE CHECKLIST

1. Make sure the opening is square and the caulk joints are 1/2" minimum around the frame.
2. Ensure surface that will be sealed are free of contaminants that can lead to adhesion issues.
3. Check that all weeps and baffles (optional, if requires) conform to the locations and sizes called out in these instruction.
4. Seal ends of horizontal frame members that are joined to vertical members.
5. Water dam installation and sealing is critical to system performance. check installation against instructions to ensure conformity.
6. Apply sealant between all corner gasket joints.
7. Glass bites must be equal on all sides except as noted below.
8. Double check anchor size and location against installation instructions or approved shop drawings.
9. Ensure aluminum pressure plate fasteners are torqued to 30-40 in-lbs.
10. Refer to current FPA documents for approved frame and glazing configurations.
11. Pre-shim interior side of glass prior to installing the pressure plate. this is critical for proper wet glazing

GLASS SIZE CALCULATION

Vertical & Horizontal Mullions D.L.O. + 1- 1/4"

CAUTION

Mandatory Installer Requirements for Structural Glazed Applications

The performance and structural integrity of a structural sealant glazed (SSG) framing system is dependent upon proper sealant selection and installation procedures.

Structural sealant selection and application is the responsibility of the erector, installer and/or glazing contractor and must be approved by the sealant manufacturer with regard to application and compatibility for its intended use. All sealants must be used in strict accordance with the sealant manufacturer's instructions and applied only by trained personnel to surfaces that have been properly prepared.

The structural sealant affixes the glazing infill to the framing system and must not experience adhesive or cohesive failures from structural or environmental project design requirements. The sealant's ability to perform depends on many factors including but not limited to proper sealant selection, surface preparation, infill type, frame finish type, environmental conditions at application and curing, horizontal and vertical system movements, sealant shelf life, cure time, handling, and compatibility of other materials in contact.

Proper adhesion to infill and framing is critical. Structural sealant must be compatible with all materials in contact, including frame finish (paint, anodize, power coating, etc.) , glazing materials (gaskets, tapes, sealants, etc.), infill surface (glass, panel, etc.) , and cleaning materials. Consult the sealant manufacturer for compatibility assessment, application instructions, and adhesion testing. Special surface preparations such as priming may be required by the sealant manufacturer.

It is the responsibility of the installer to ensure all glazing infills be reviewed and approved by the infill manufacture for use in SSG applications. Infills include but are not limited to glass, metal panels, stone, etc. Design modifications of the infill may be required for use in SSG applications.











Mandatory Installer Certification Required for 3M VHB Tape Applications

The performance and structural integrity of VHB tape glazed framing system is dependent upon proper VHB tape selection and installation procedures.

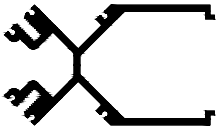

Installers are required to be trained and certified 3M personnel prior to VHB tape procurement, application, and glass installation. See 3M website (<https://www.3m.com>) for contact information.

In addition to training and certification, approved shop drawings including design loads, infill type, frame finish, frame sizes, frame installation, and finished sections of the framing must be sent to 3M for approval.

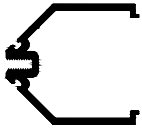



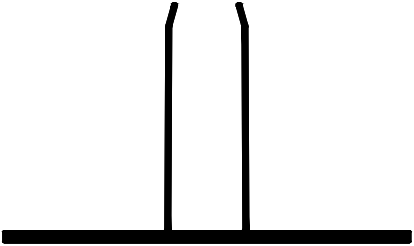
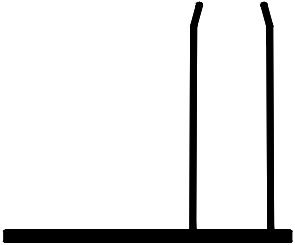
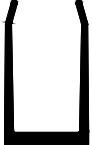

TYPICAL FRAMING EXTRUSIONS

SHAPE	DESCRIPTION	PART No.
	Captured Mullion/Horizontal	E55TB02FS
	SSG Mullion	E55TB04FS
	SSG Horizontal	E55TB252FS
	Pressure Bar	M4TB102FS
	Perimeter Pressure Bar	M5TB251FS
	3/4" Depth Cap (Standard)	E4TB64FS
	Glass Pocket Filler	E6642FS
	Corner Mullion	E6TB02FS
	90° Outside Corner Nose Adaptor for Captured Glazing	E5TB110FS
	90° Outside Corner Pressure Bar for Captured Glazing	E5TB250FS
	90° Outside Corner Nose Adaptor for SSG Glazing	E5TB67FS





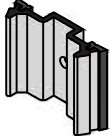

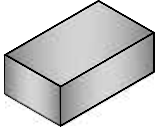
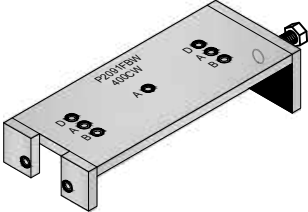





ANCHORS and CLIPS

SHAPE	DESCRIPTION	PART No.
	Shear Block for Horizontals	PTB60F
	'T' Anchor for Mullions	Captured PTB21B
		SSG PTB21A
	'F' Anchor for Jambs	PTB20B
	'U' Anchor for Door Jambs	PTB22
	Perimeter 'F' Clip Anchor	E6613FS

ACCESSORIES

SHAPE	DESCRIPTION	PART No.
	Thermal Isolator Gasket	PTB94
	Glazing Gasket for Captured Glazing	PTB28
	SSG Spacer Gasket for Silicone Glazing	PTB106
	Setting Block for 15/16" Glazing	P6550 (Silicone)
	Temporary Glass Retainer	P1195
	Weep Baffle - used at Face Covers 1/2" x 1" x 3"	PTB42
	Water Dam for Captured Glazing	PTB193
	Water Dam for SSG Glazing	PTB76A
	Drill Fixture	P2091FB

FASTENERS

SHAPE	DESCRIPTION	PART No.
 	#14-14 x 1/2" HH type 'F'	S139
 	#10-24 x 3/4" PH Self Tapping	S270
 	1/4-20 x 1 1/2" HWH type 'F'	S359
 	1/4-20 x 3/4" HWH type 'CA'	S369
 	1/4-20 x 2" HWH Bolt for Corner Mullion Nose at E5TB110FS	S428
 	1/4-20 x 3/4" FH thread cutting, type 'F'	S6505

ELEVATION TYPES

TYPES OF CURTAIN WALL INSTALLATION

The 400 Series curtain wall system can be constructed a variety of ways. The most common are single span, twin span and multi-span as illustrated below. Refer to approved shop drawings for specific guidance on splicing and anchoring.

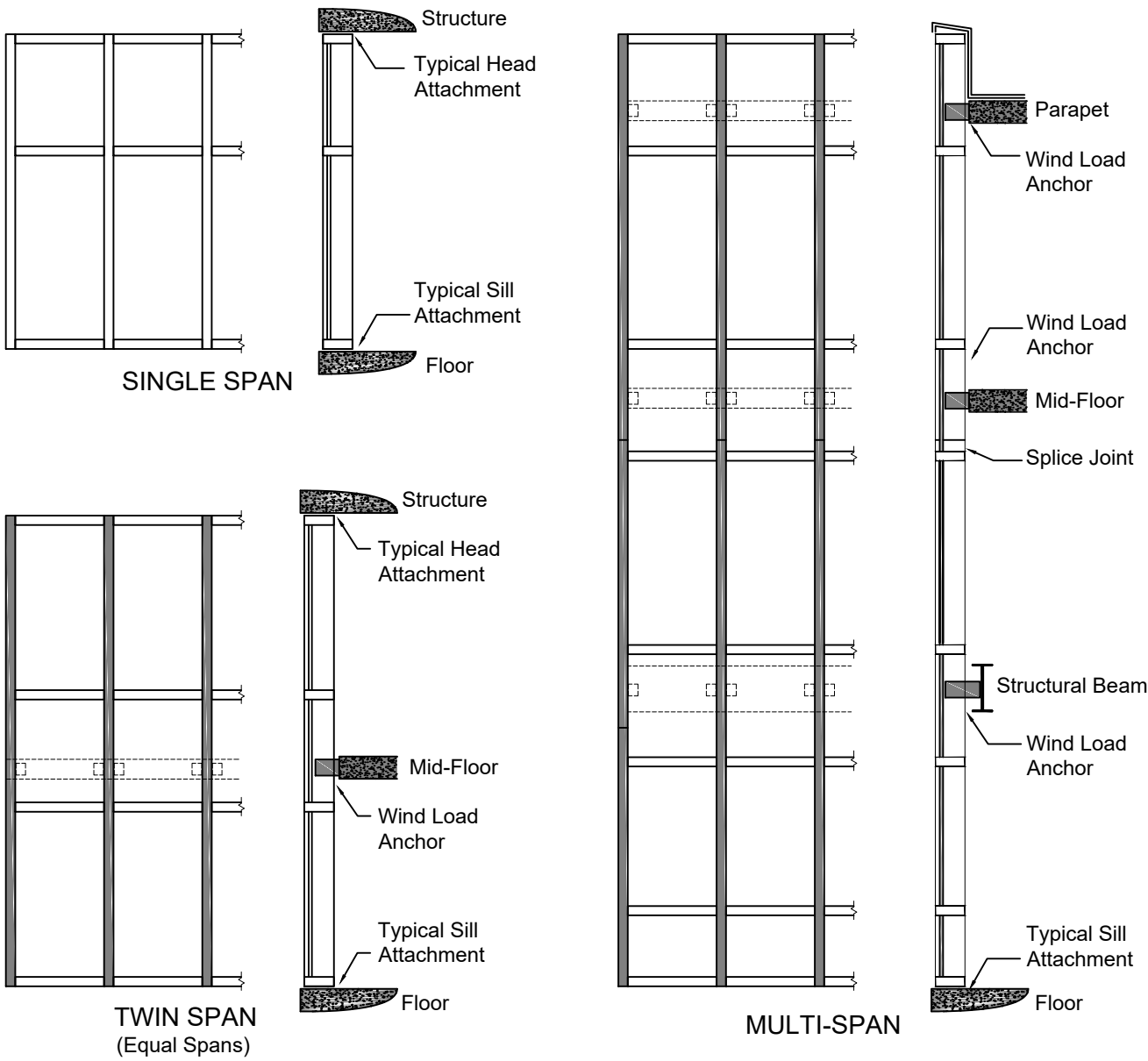

Span configurations will vary per project requirements. Conditions must be approved by engineer calculations.

Fig. 10.1

ELEVATION and WALL SECTIONS

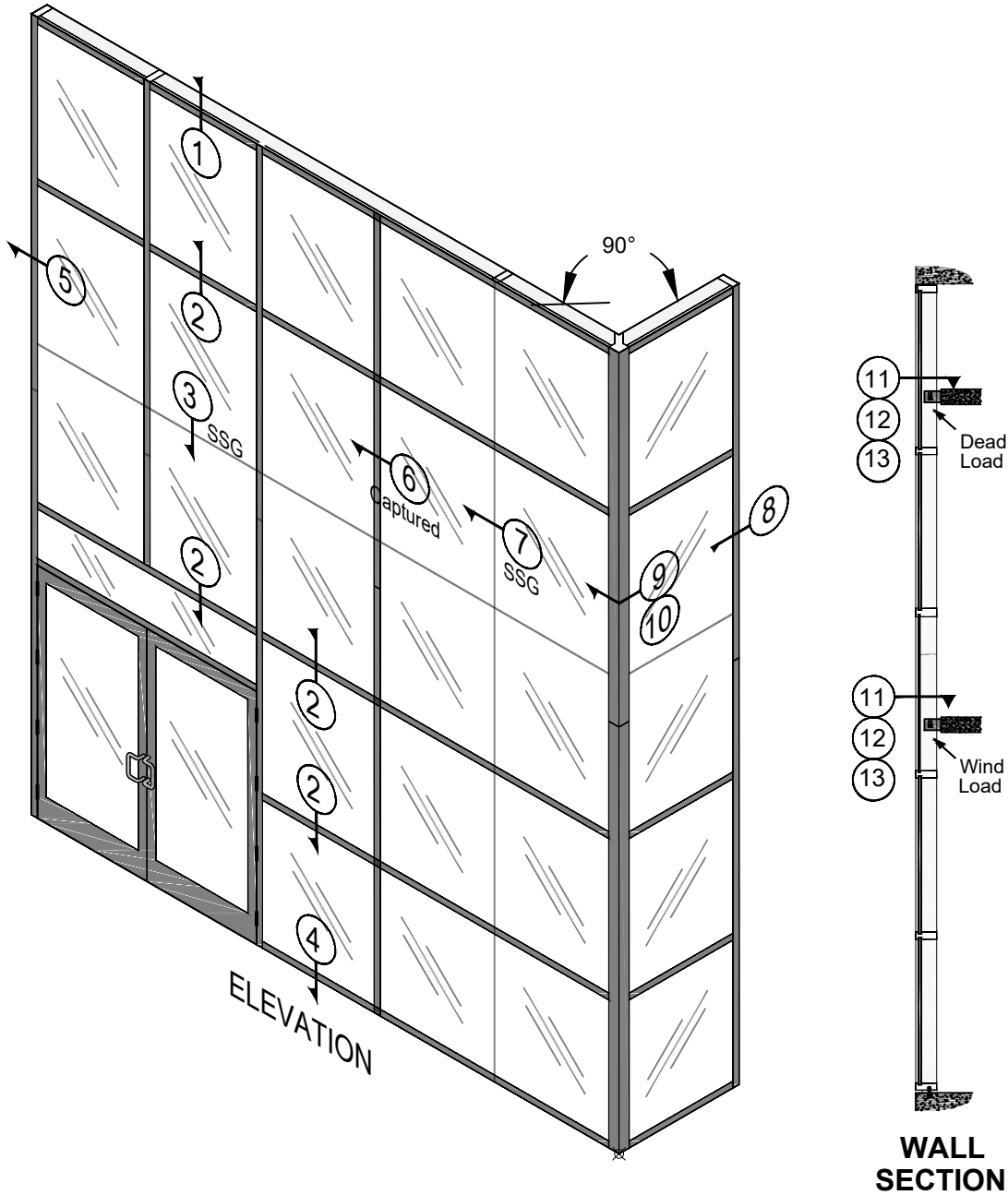
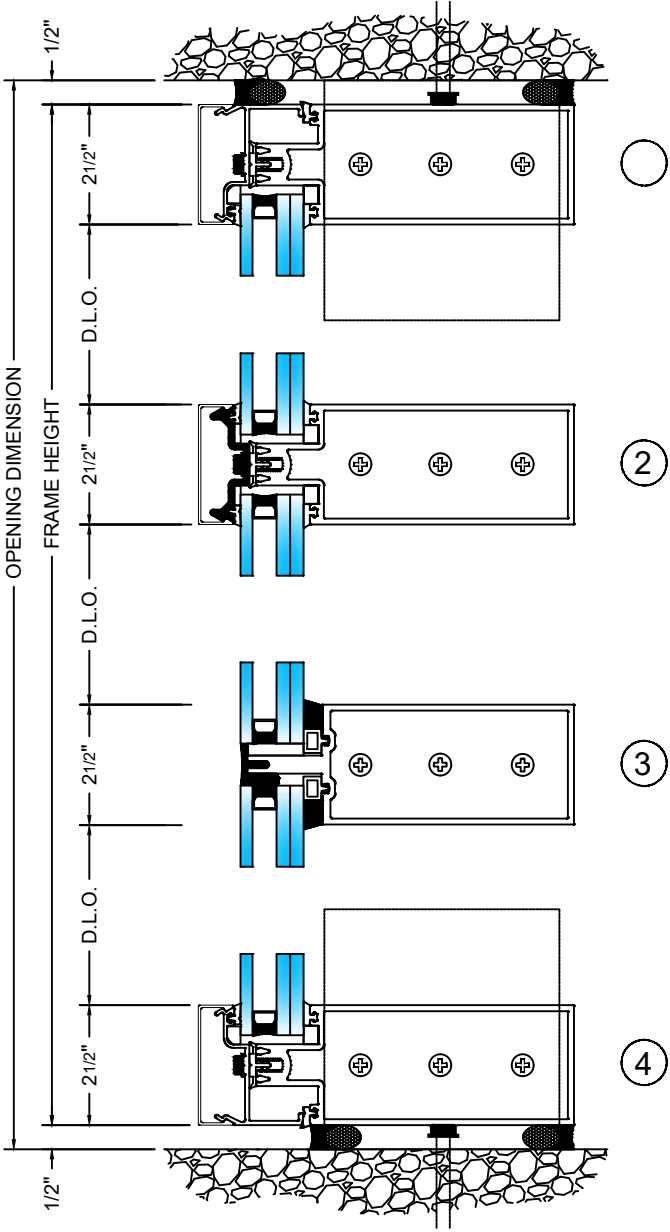

Fig. 11.1

HORIZONTAL DETAILS



HORIZONTALS

Fig. 12.1

NOTE:
For interior dry glazing option, which is available based upon design pressures and glass make up, contact Tubelite.

VERTICAL DETAILS

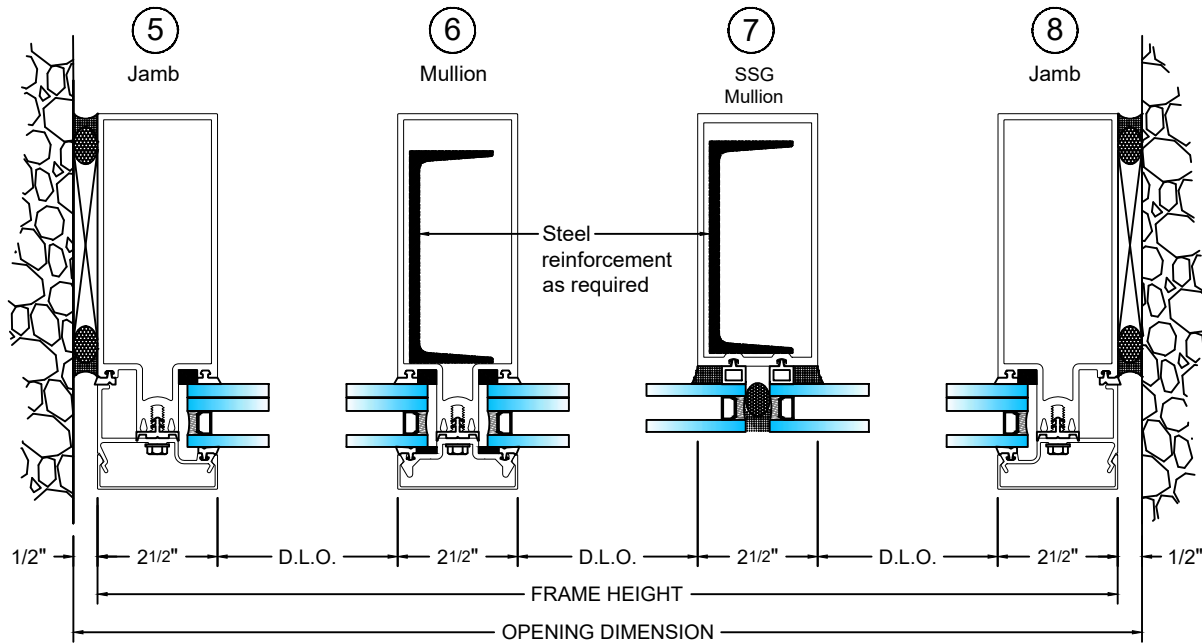

VERTICALS

Fig. 13.1

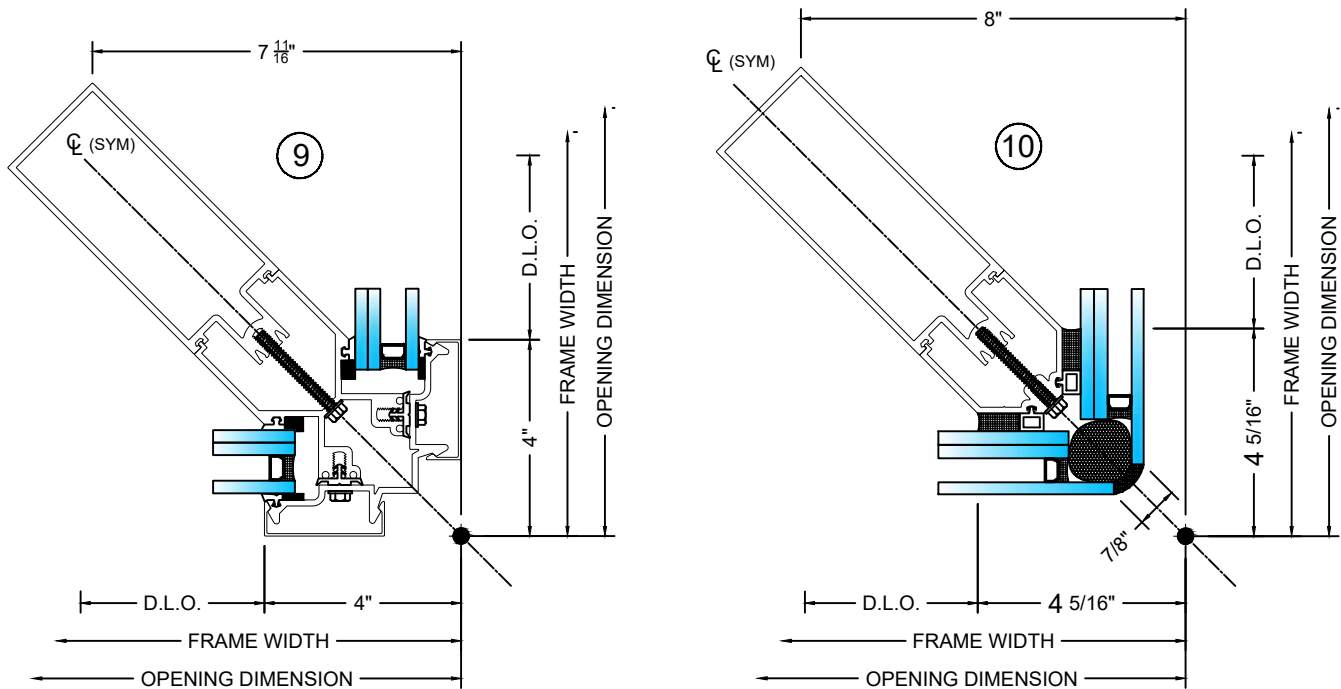

90° CORNERS

Fig. 13.2

MID-SPAN ANCHOR DETAILS

Anchor details on pages 14 through 16 represent one of several methods of anchoring for both captured and silicon glazing. Refer to approved shop drawings for job specific applications.

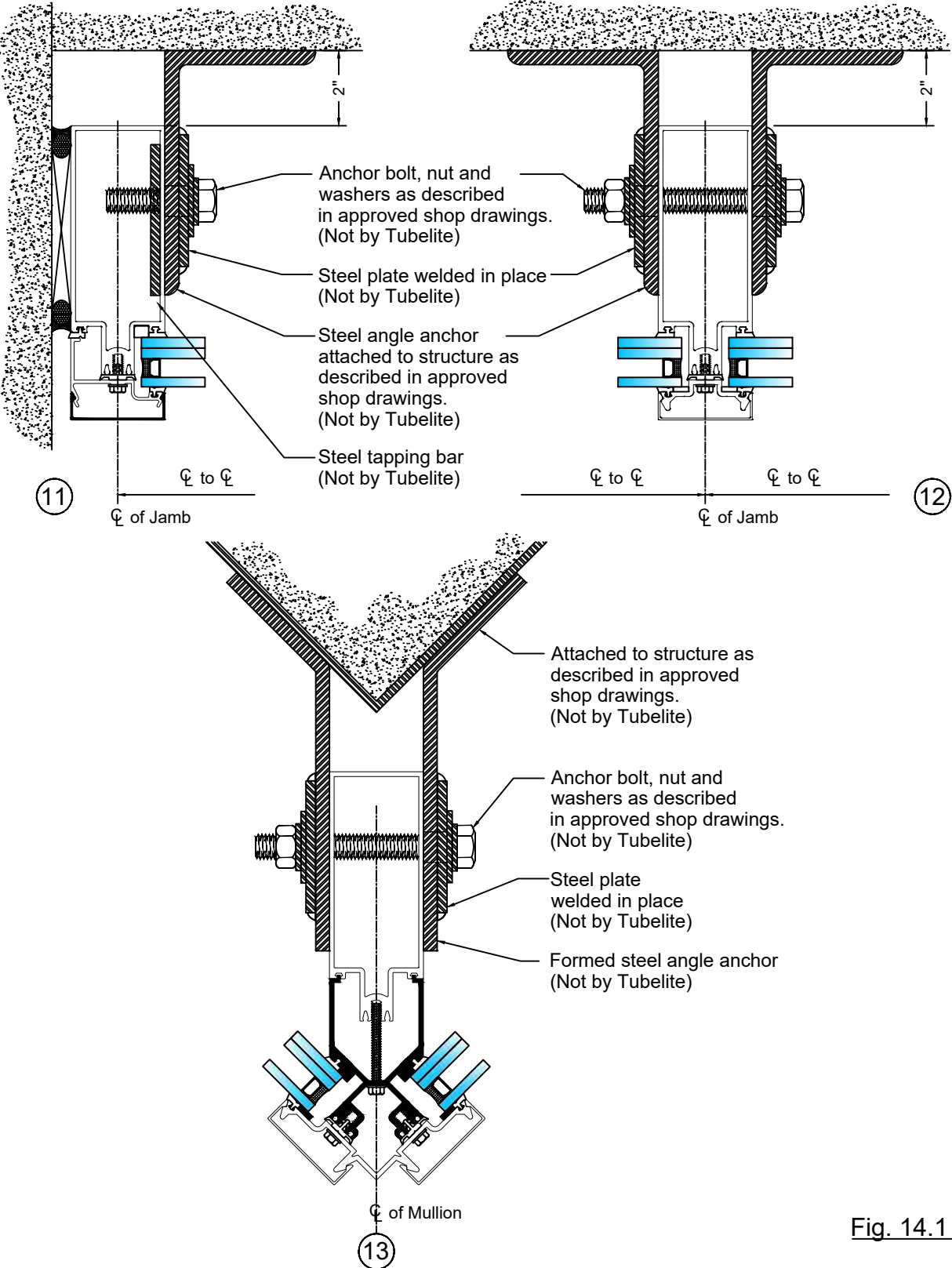

Fig. 14.1

MID-SPAN ANCHOR DETAILS

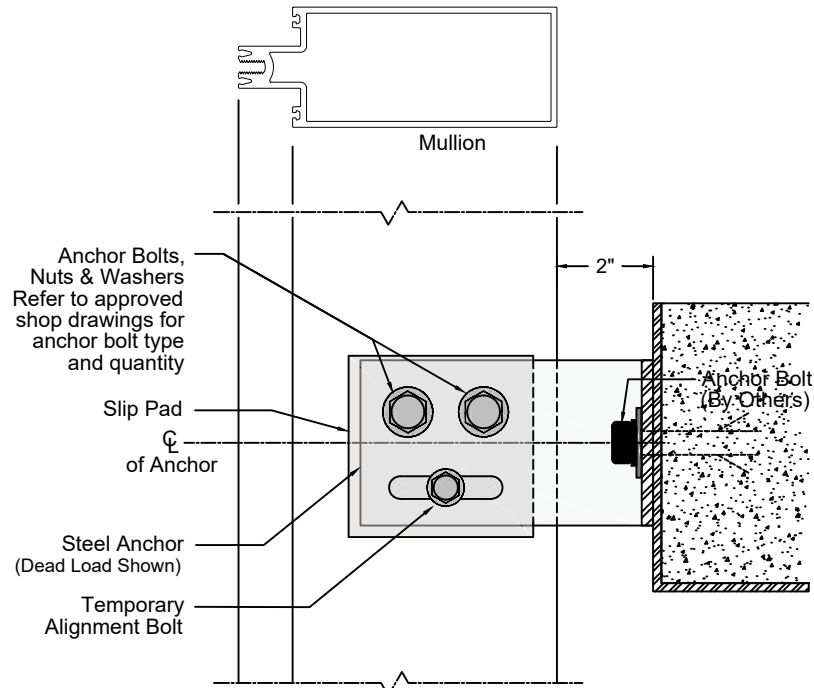

Fig. 15.1

Intermediate Mullion

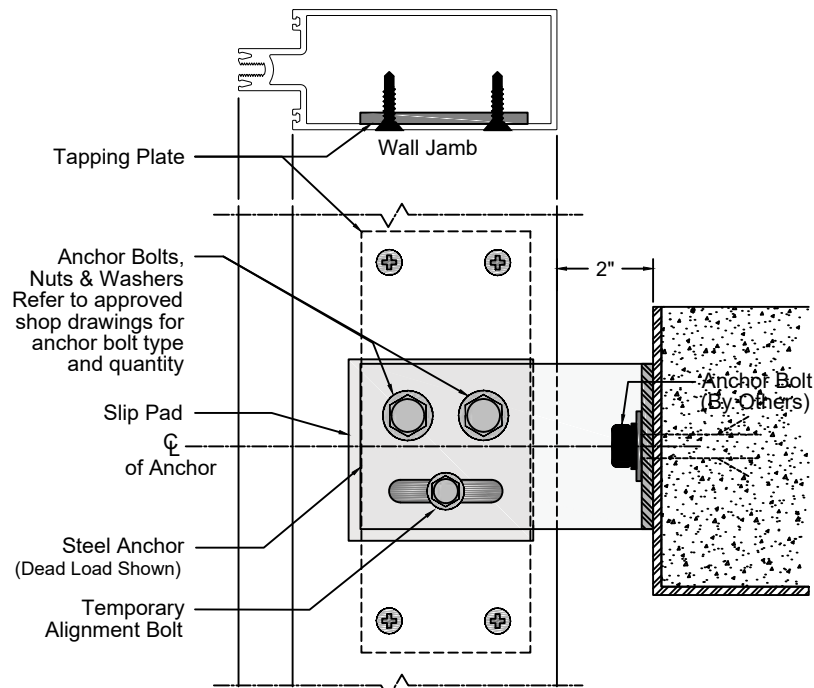
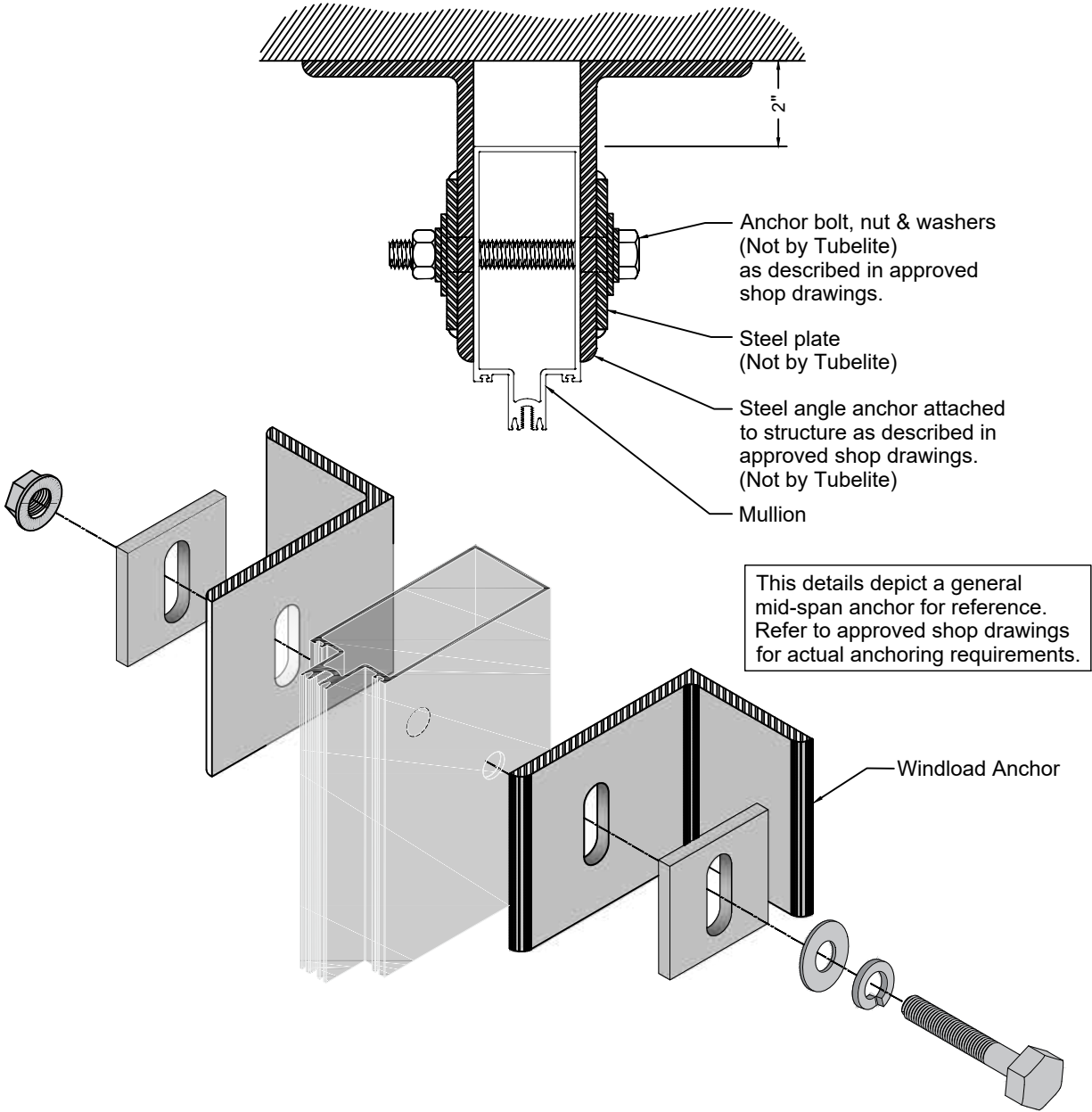

Fig. 15.2

Jamb Mullion

MID-SPAN ANCHOR DETAILS



FRAME FABRICATION

Step 1: Determine Frame Size

Frame Width

- A. Make sure the opening is square and plumb. Measure each diagonal of the opening. SEE Fig. 17.1.
- B. Measure the width of the opening (Rough Opening) at the top, middle and bottom. Select the smallest of these dimensions and subtract the left and right caulk joint width per approved shop drawing (1/2" minimum caulk joint at jambs). SEE Fig. 17.2.
- C. Allow a larger clearance to accommodate building tolerances, an out-of-square opening, anticipated thermal expansion within the unit or as required by shop drawings.

Frame Height

- D. Measure the height of the opening (Rough Opening) at several points along the entire width of the opening. Select the smallest of these dimensions and subtract 1" to allow a minimum of 1/2" at sill and head for shim and caulking. SEE Fig. 17.3.
- E. Allow a larger clearance to accommodate building tolerances, an out-of-square opening, anticipated thermal expansion within the unit or as required by shop drawings.

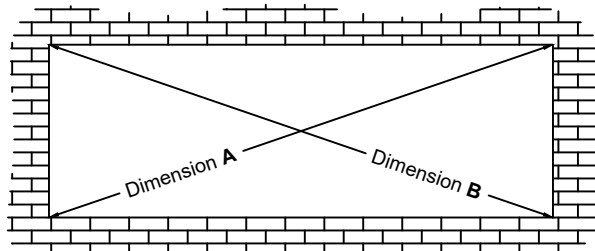

Fig. 17.1 Dimension "A" = "B"

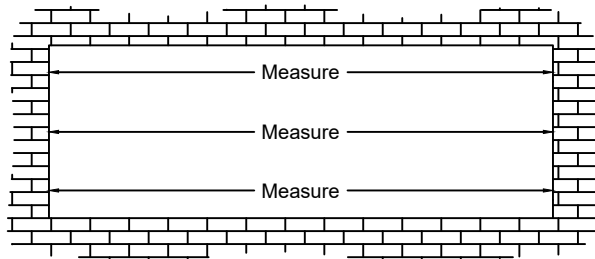

Fig. 17.2

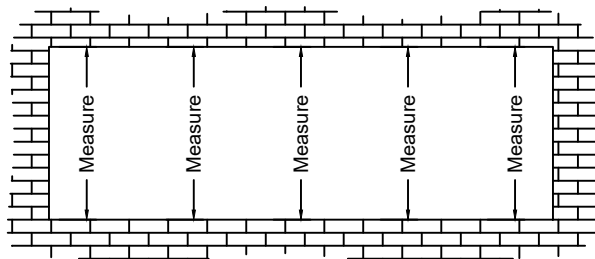
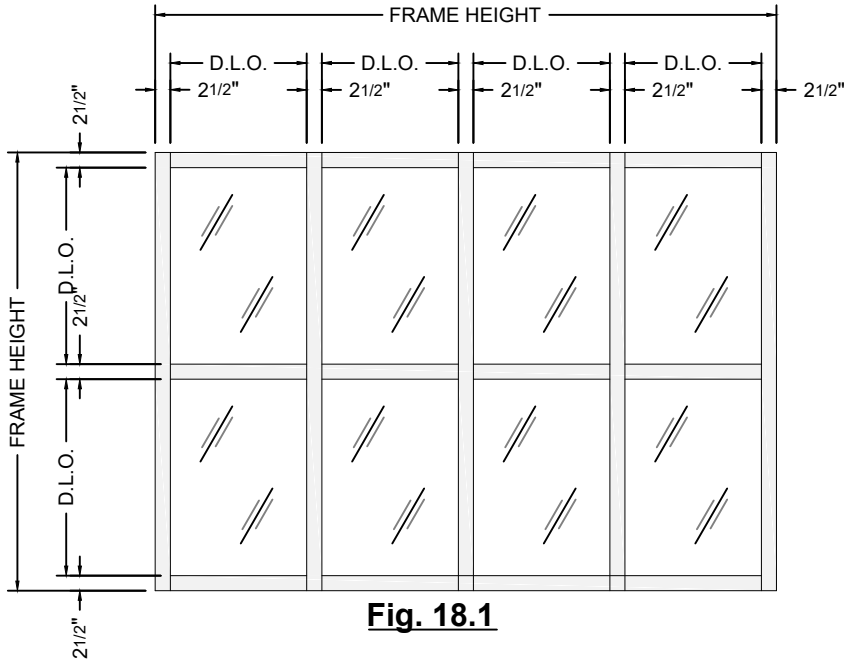

Fig. 17.3

FRAME FABRICATION

Step 2: Captured Framing - Cut Materials to Size



Cut extrusions to lengths as shown below:

Vertical Profiles:

- Vertical Mullion = Frame Height
- Pressure Plates = Frame Height
- Face Caps = Frame Height

For frames that receive vertical splicing, see step 12, page 27 and step 19, pages 41 - 42.

Horizontal Profiles:

- Tubular Head, Sill & Horizontal = D.L.O.
- Open Back Head, Sill & Horizontal = D.L.O. MINUS (-) 1/32"
- Pressure Plates = D.L.O. MINUS (-) 3/8"
- Face Caps = D.L.O. MINUS (-) 1/32"

Accessories:

- Exterior Vertical Gasket = Pressure Plate Length *PLUS* (+) Allowance*
- Exterior Horizontal Gasket = Pressure Plate Length *PLUS* (+) Allowance*
- Interior Vertical Gasket = D.L.O. *PLUS* (+) 1" *PLUS* (+) Allowance*
- Interior Horizontal Gasket = D.L.O. *PLUS* (+) Allowance*

*Allowance = 1/8" extra length per foot of D.L.O. or aluminum length

Note: Door framing material is cut to size from the factory.

FRAME FABRICATION

Step 3: Drill Holes in Vertical Members for Shear Blocks

A. Drill .201" diameter pilot holes for #14 screws in the vertical members. Use the P2091FB drill fixture to locate these holes on captured verticals.

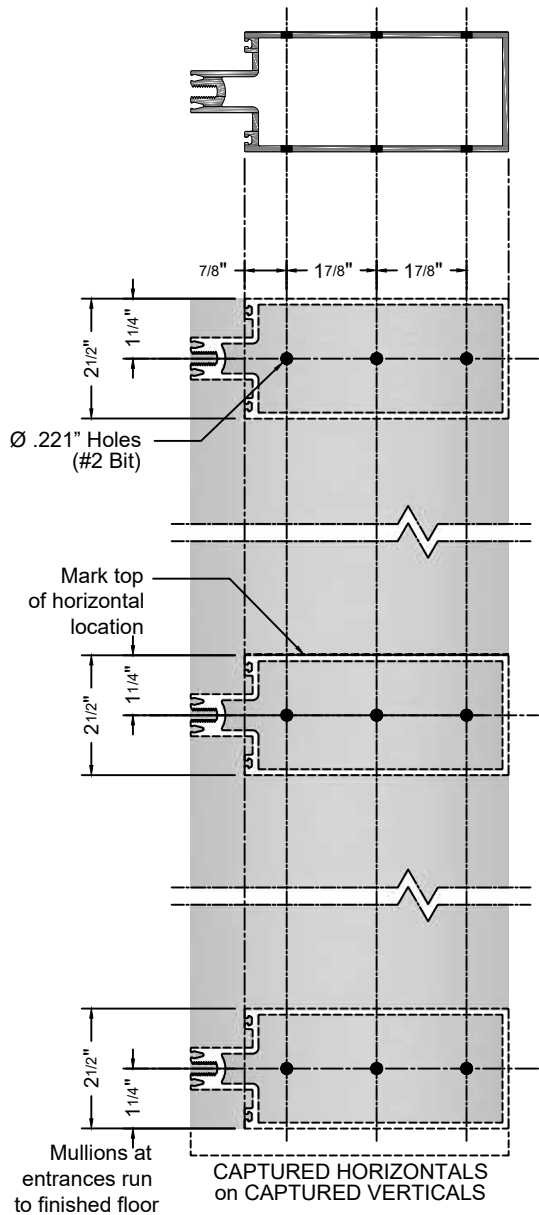

Fig. 19.1

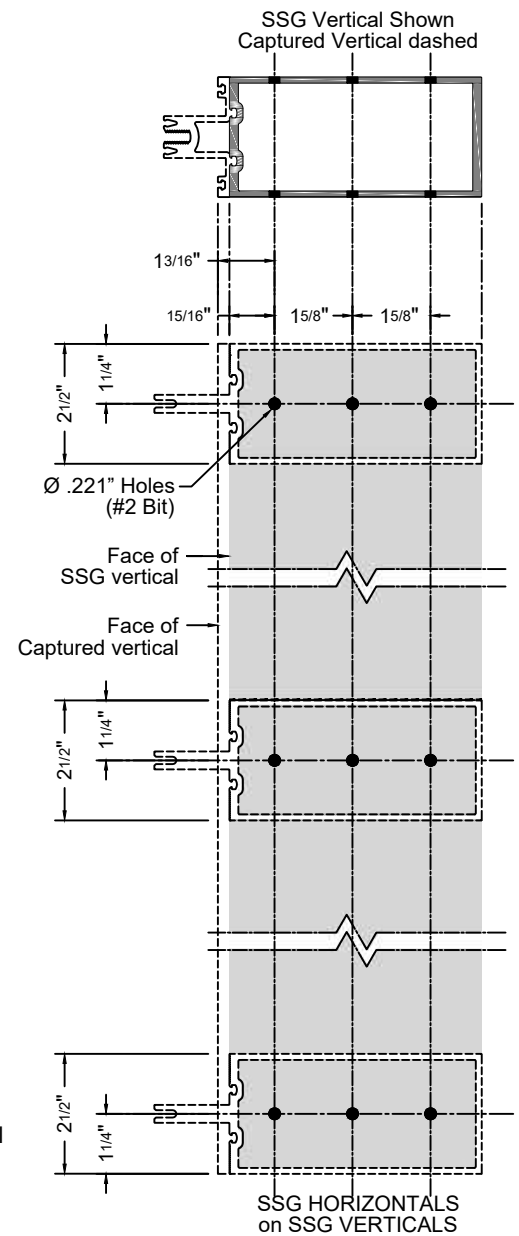

Fig. 19.3

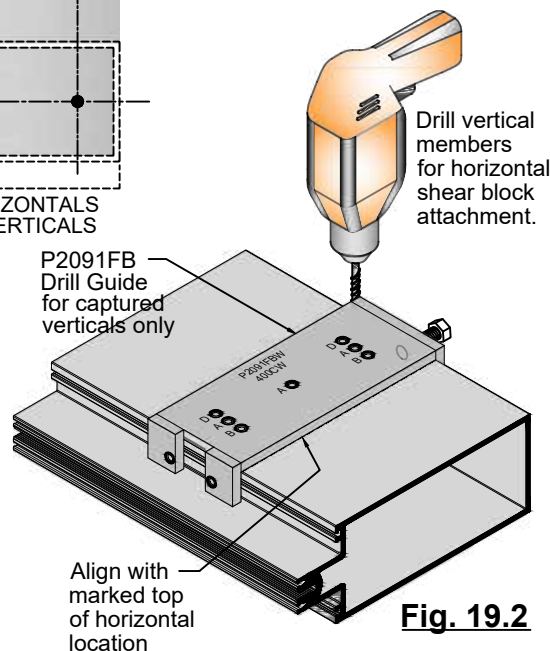
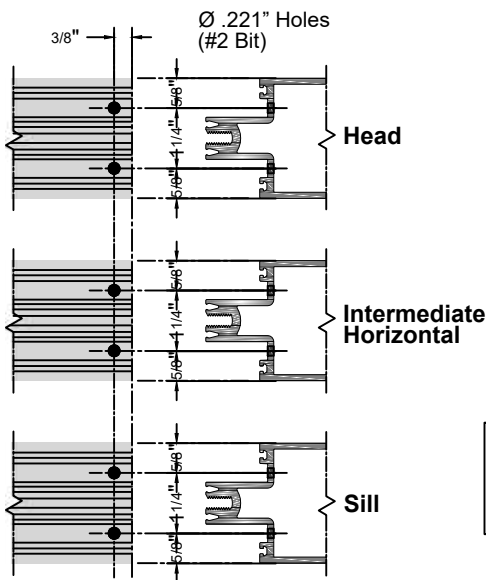

Fig. 19.2

FRAME FABRICATION

Step 4: Drill Holes in Horizontal for Attachment to Shear Blocks

- A. Drill (2) .221" diameter clearance holes for #10 screws in the horizontal sections for attachment to the shear blocks. Use the P2091FB drill fixture to locate holes. See Fig. 20.1.
- B. Drill and countersink top or bottom of each end of horizontal member as shown in Fig. 20.2. The choice of top or bottom is at the discretion of the installer.



NOTE:
 This operation also is required on SSG horizontals

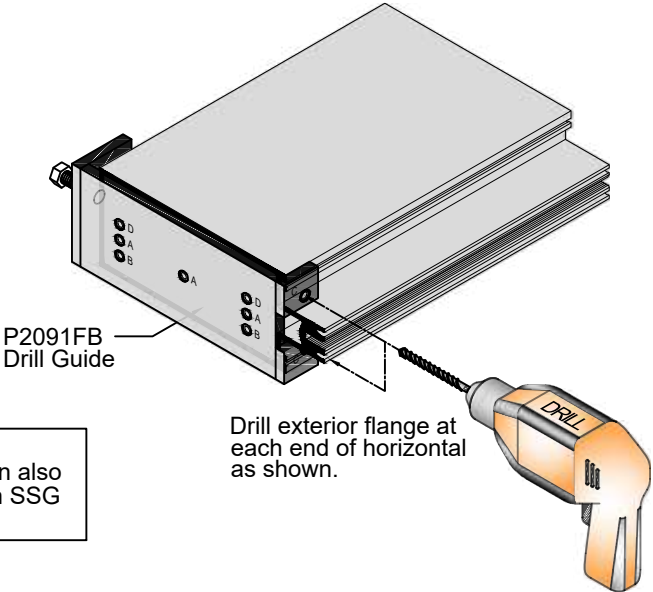
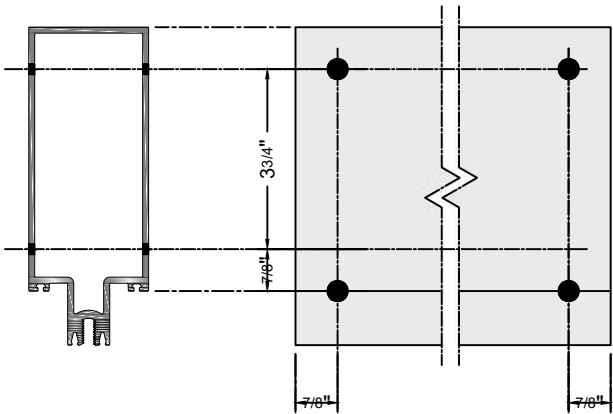

Fig. 20.1



Drill and countersink top or bottom of each end of horizontal member as shown in Fig. 20.2. The choice of top or bottom is at the discretion of the installer.

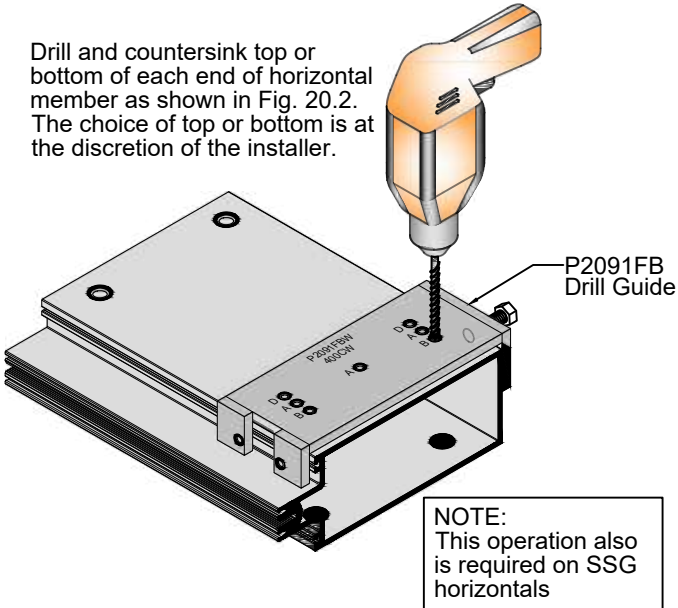
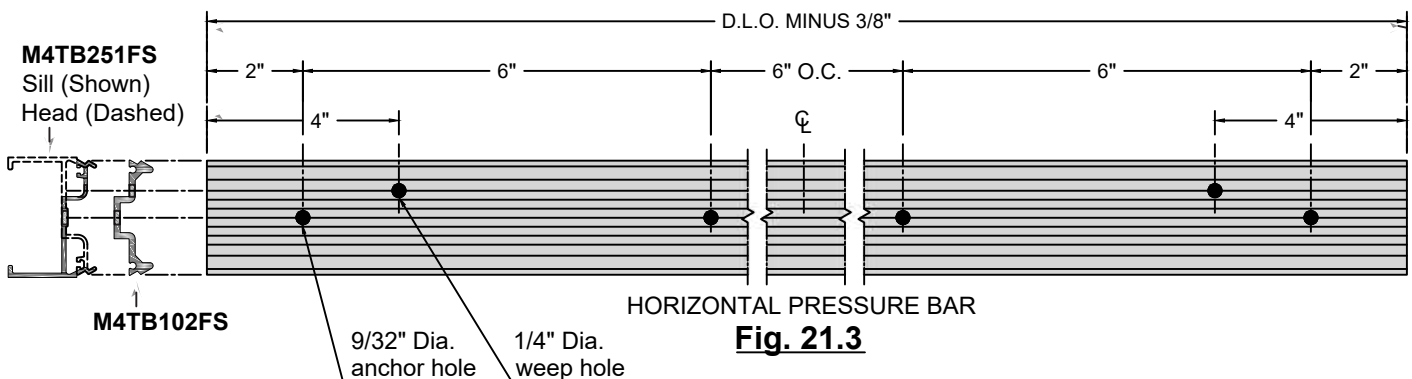
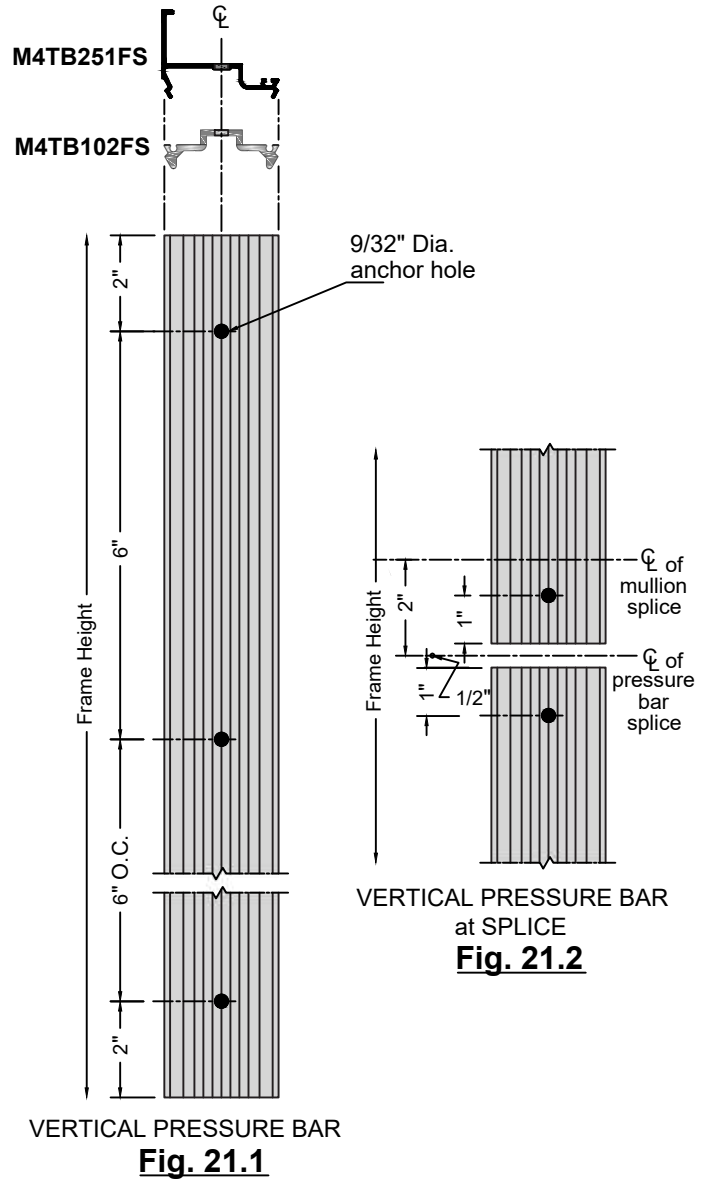

Fig. 20.2

FRAME FABRICATION

Step 5: Drill Weep Holes in Horizontal Pressure Plates

- A. Drill three 1/4" diameter weep holes per horizontal pressure plate, one at the midpoint and one at 1/8 points at each end. Locate the holes on the V-groove above the center line of the pressure plate.
- B. Pressure plates are factory punched on center for pressure plate screws. Drill additional hole(s) as required to ensure a maximum of 2" from the ends of the plates.



FRAME FABRICATION

Step 6: Fabricate Weep Slots in Horizontal Face Covers

- A. For Single Spans: Fabricate a 1/4" x 1" weep slot on the bottom of each horizontal face cover a maximum of 1" from each end of the cover.
For Twin Spans: Fabricate a 1/4" x 1/2" weep slot on the bottom of each horizontal face cover a maximum of 1-3/16" from each end of cover.

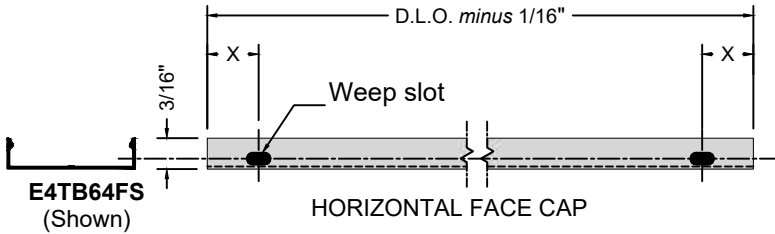

Fig. 22.1

Step 7: Notch Heads and Sills to Clear Shear Clips

- A. Notches must be cut in the head and sill members to provide clearance for the shear blocks.
See Fig. 22.2 for proper notch size.

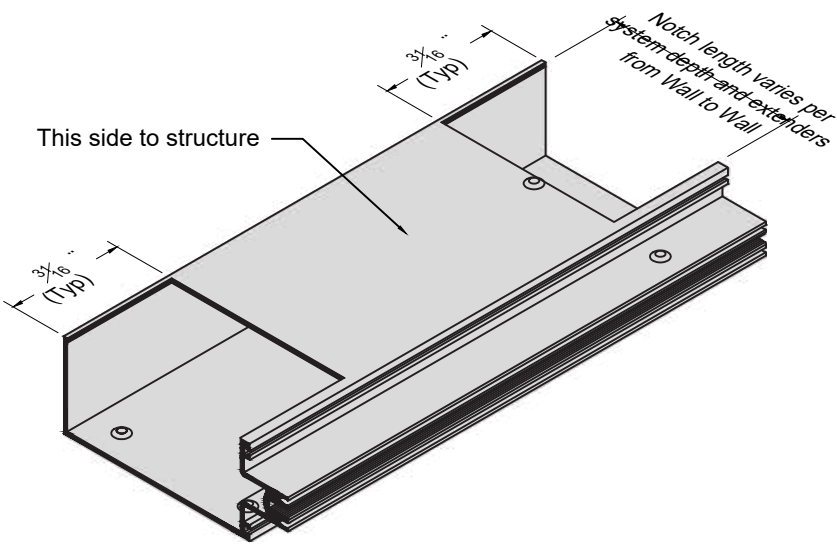

Fig. 22.2

Step 8: Fabricate Continuous F-Clip Perimeter Anchor

- A. Fabricate notching of anchor leg to clear 'T' and 'F' vertical anchors as shown in Fig. 23.2. Also see optional method shown on page 24.

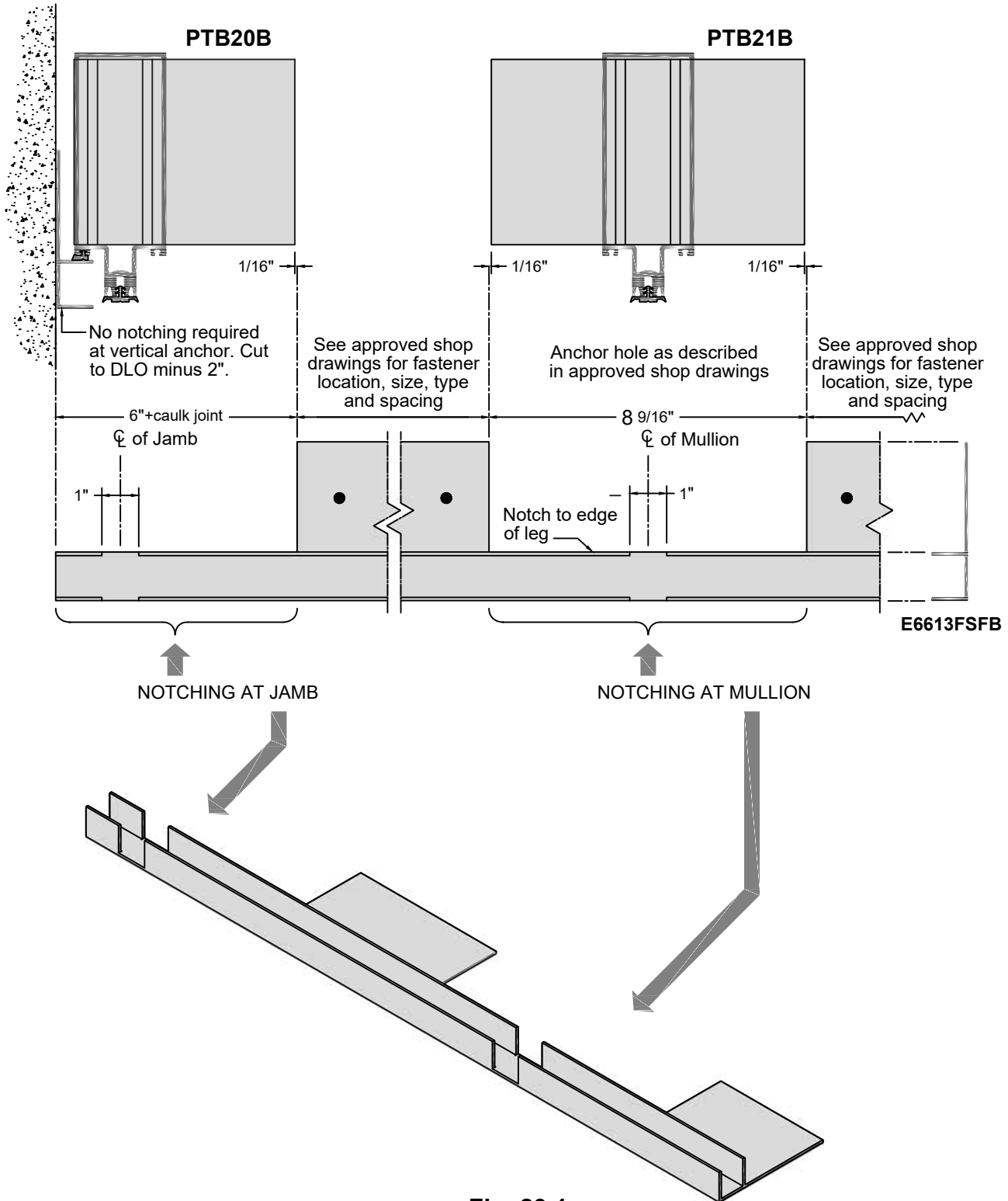

Fig. 23.1

Step 8: Fabricate F-Clip Perimeter Anchor (Optional Method)

- B. Cut and fabricate to fit between 'T' and 'F' vertical anchors as shown in Fig. 24.1.
Vertical anchor clip runs continuous from head to sill.

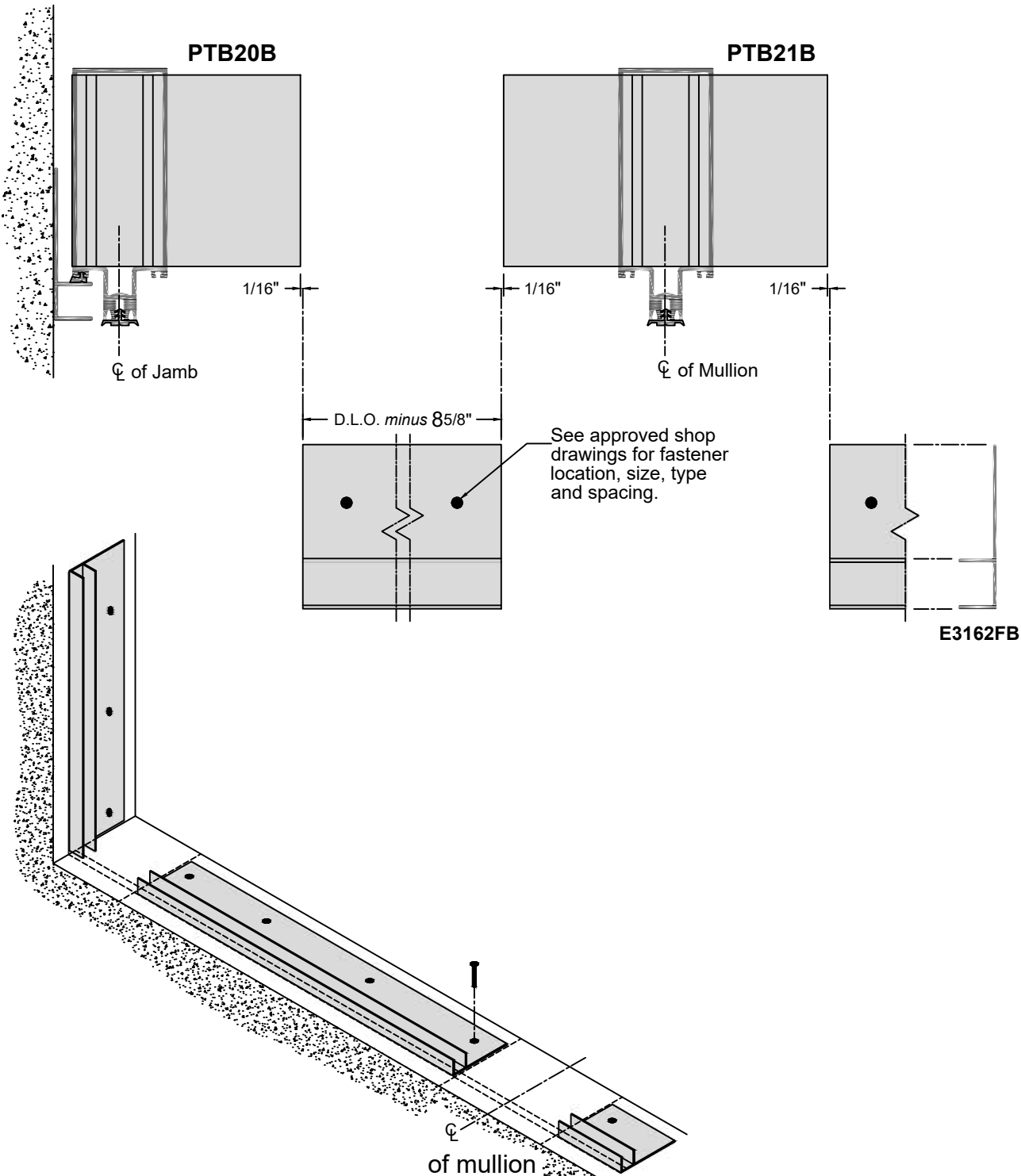

Fig. 24.1

FRAME FABRICATION

Step 9: Install Steel Reinforcement As Required

- A. Refer to approved shop drawings to determine where steel reinforcing may be required.
- B. Steel should be installed prior to the attachment of shear blocks.
- C. Steel should be sized to stop short of the top and bottom of the vertical for clearance.
- D. Locate and prep for attachment of the steel located under the horizontal shear blocks if possible. Otherwise, steel can be secured to the vertical mullion through the tongue. Anchor the steel to the vertical using fasteners and spacing per approved shop drawings (not supplied by Tubelite).

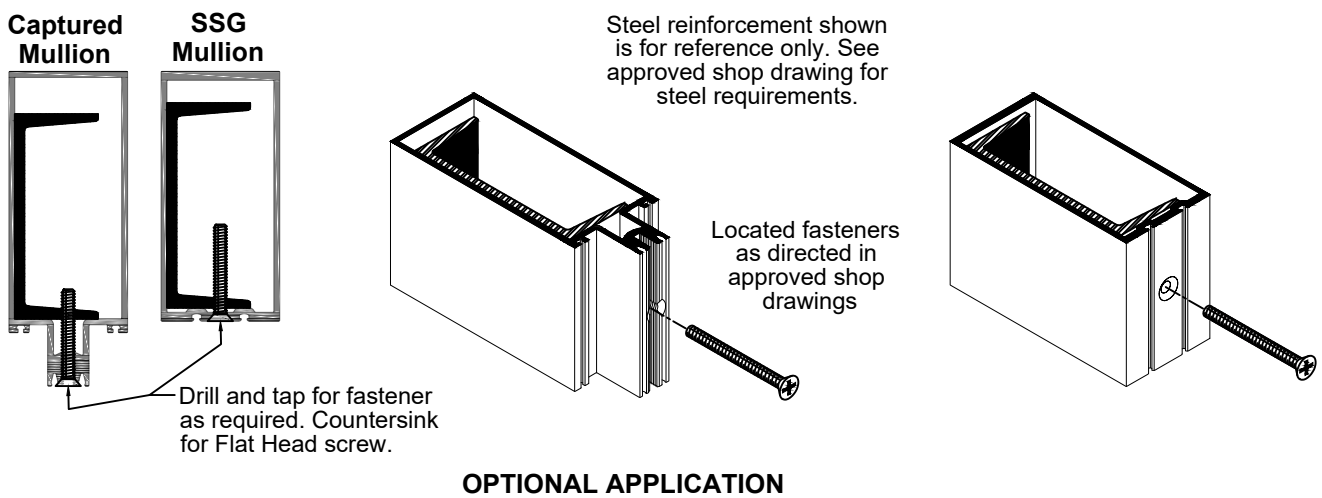
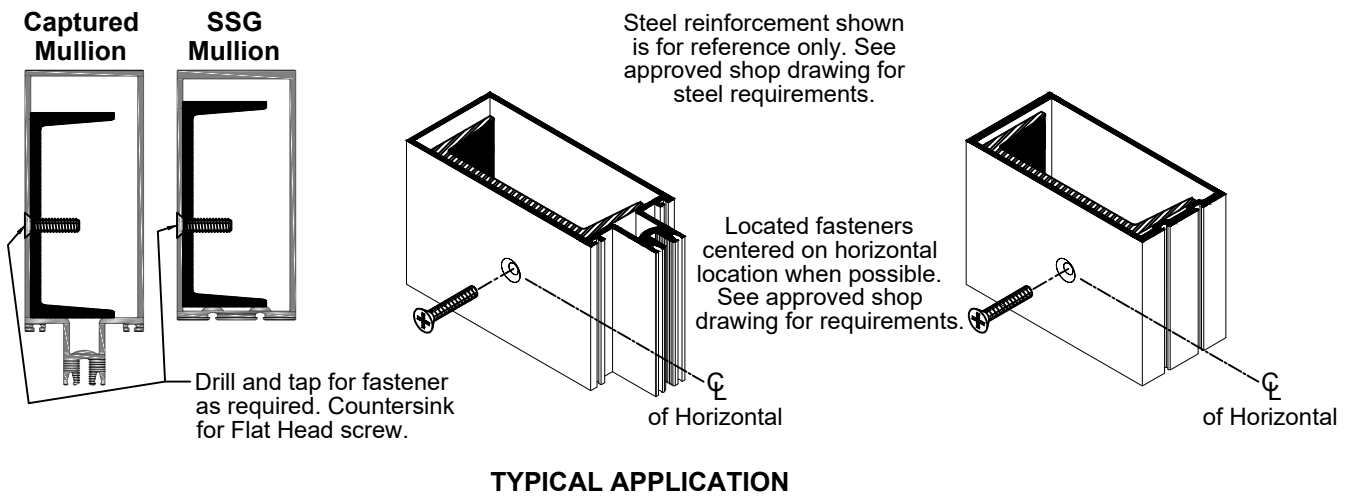

Fig. 25.1

FRAME FABRICATION

Step 10: Fasten Shear Blocks

- A. Fasten the shear blocks for tubular horizontals to the verticals using (3) S139 fasteners.
NOTE: If steel reinforcement is required, it must be installed prior to shear block attachment.

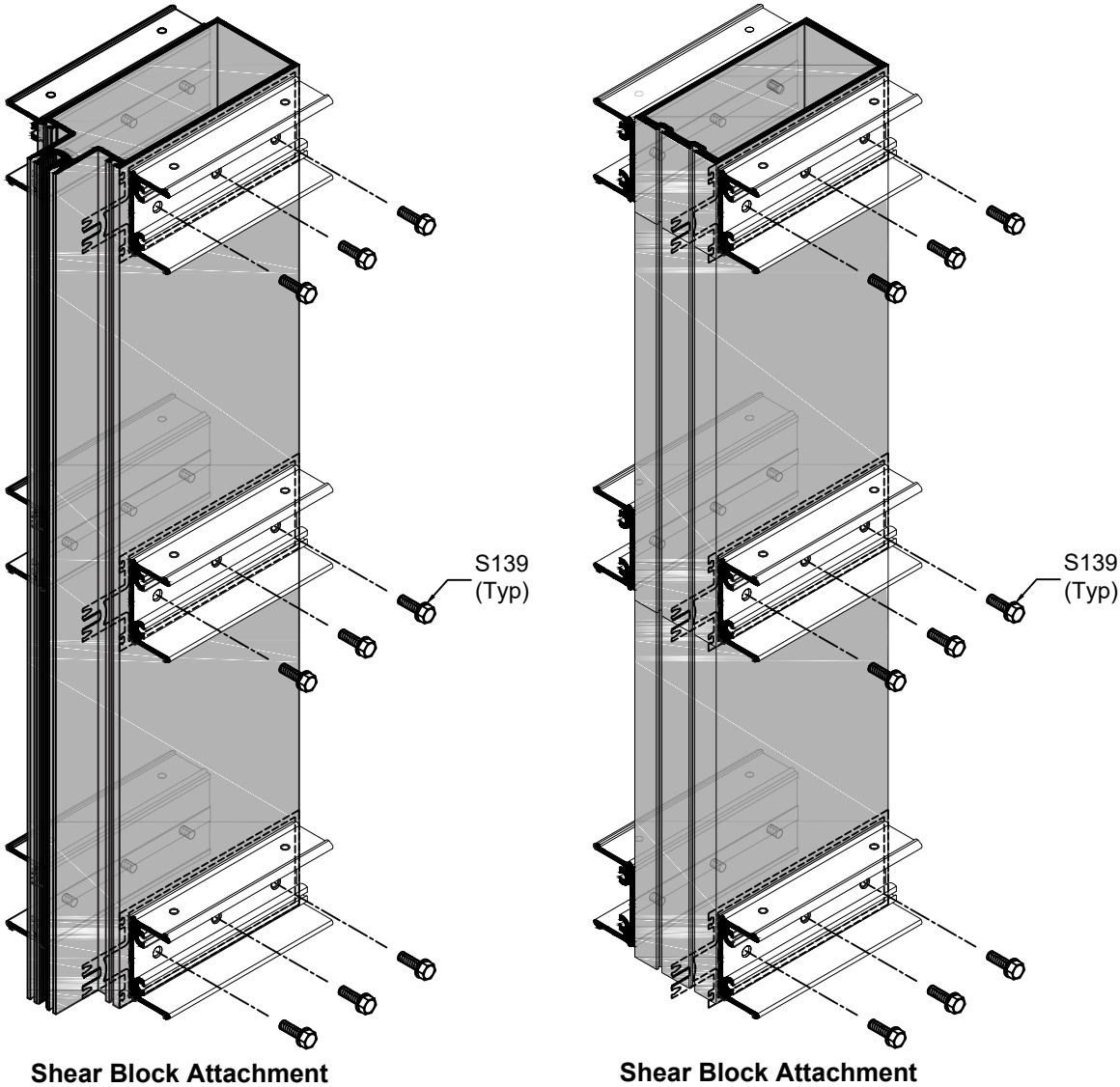

Fig. 26.1

FRAME FABRICATION

Step 11: Install Head or Sill F and T Anchors

- A. Fasten a shear block to the vertical mullion using S139 screws at the head or sill in place of an anchor clip. Refer to Step 9 for shear block installation.
- B. F and T anchors can be pre-loaded into the top and bottom of the verticals and temporarily secured with tape for transit to the job site.

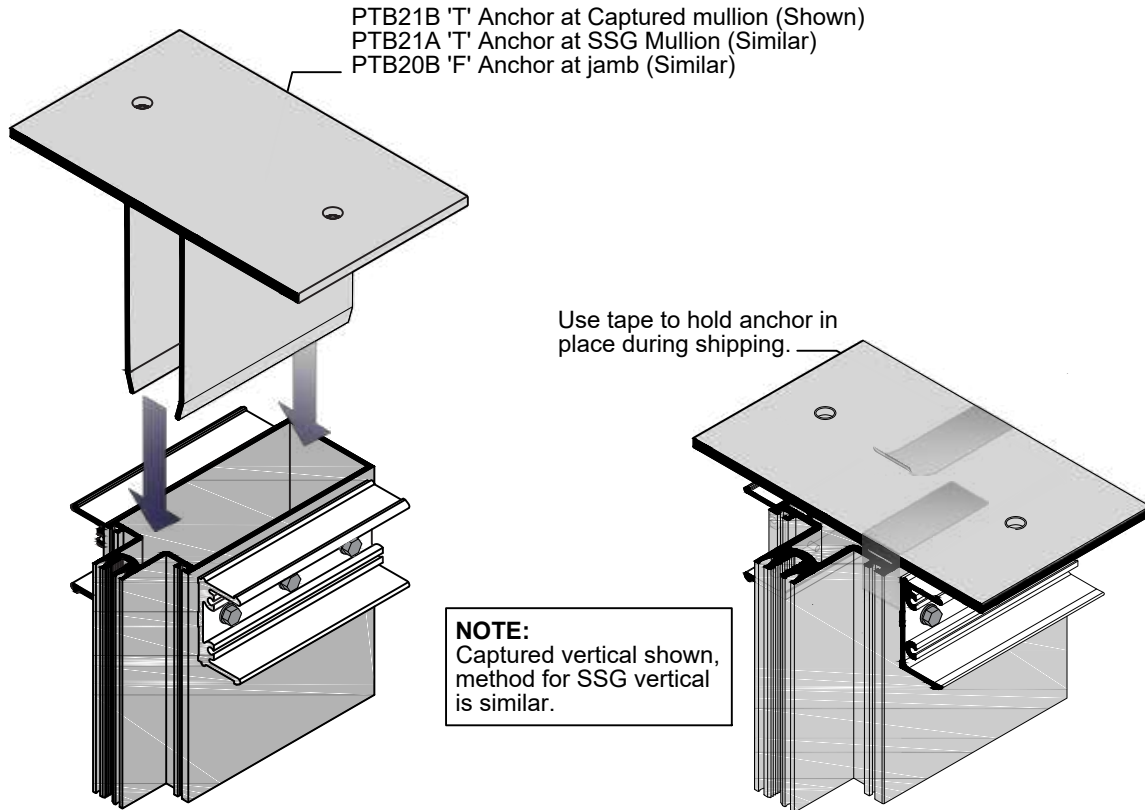

Fig. 27.1

FRAME INSTALLATION

Step 12: Installing Vertical Mullions

NOTE: Check D.L.O. and diagonal dimensions every four bays to ensure correct spacing and frame squareness.

T or F Anchor Installation

- A. Install vertical mullions plumb and level, shimming between the bottom of the vertical and T or F anchor for proper deadload distribution.
- B. Anchor Top F anchor to building per approved shop drawings.
 NOTE: Do not shim the top of the vertical to allow for thermal and liveload movement.

Multi-Span Installations

- A. Install lower vertical mullion plumb and level, shimming between the bottom of the vertical and T or F anchor for proper deadload distribution.
- B. Anchor T or F anchor to building per approved shop drawings.
- C. At the mid-span anchor, temp the vertical in place plumb and level. Check joint at the mullion splice and use a shim to hold joint at the correct size.
- D. When the entire frame is installed and securely anchored to the mid-span anchor(s), remove shims from the vertical mullion splices and back off nut 1/4 turn at all windload anchor connections and stake the bolts. Be sure any temporary screws are removed from windload anchors.
- E. Refer to Step 12, page 27 to complete the splice sleeve installation.

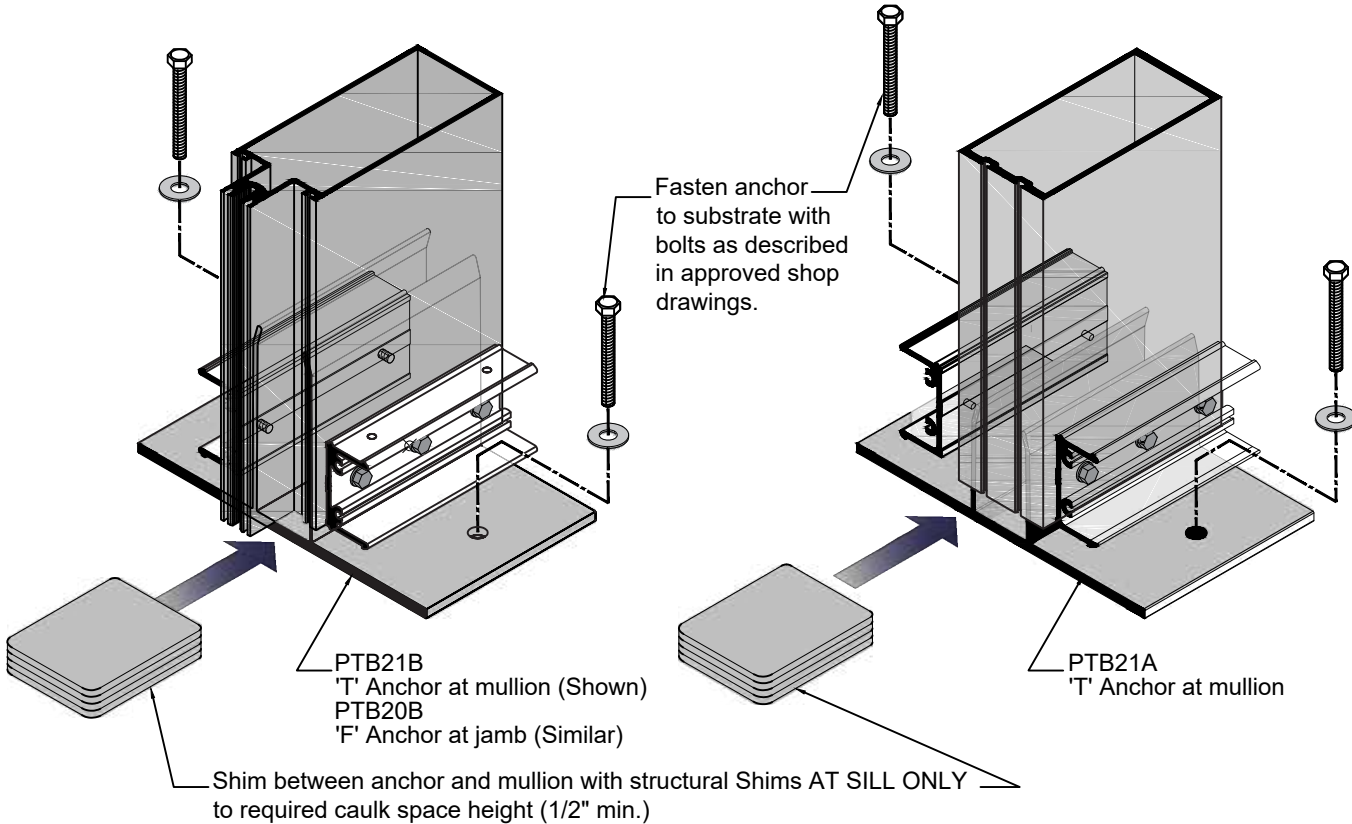

Fig. 28.1

Sill condition shown, head condition similar.

FRAME INSTALLATION

Step 13: Splice Sleeve Attachment

- A. Consult approved shop drawings for number and size of fasteners required to attach the splice sleeve to the verticals.
- B. Drill holes on both sides of the lower vertical in the locations shown on the approved shop drawings.
 NOTE: Figure 29.1 shows typical hole pattern.
- C. Slide the splice sleeve into the upper vertical mullion. Tape the sleeve into position temporarily until verticals are erected. See Fig. 29.2.
- D. After the lower and upper verticals are erected, remove the tape holding the splice sleeve and slide into place, securing to the lower mullion as shown on approved shop drawings. See Fig. 29.3.
- E. Apply bond breaker tape to the face of the splice sleeve between the lower and upper verticals, returning back 1" on each side.
- F. Apply sealant over bond breaker tape at joint. Tool sealant. See Fig. 29.4.

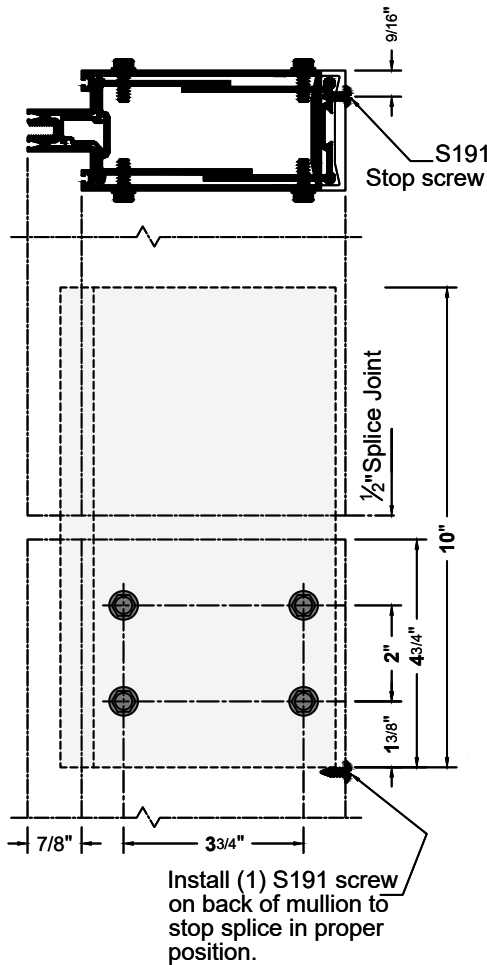
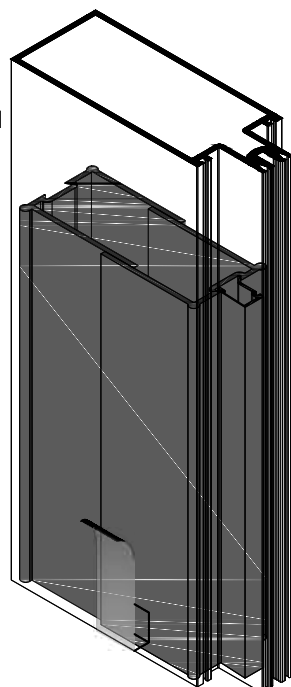

Fig. 29.1



Slide splice sleeve assembly into bottom of upper mullion and tape in place.

Fig. 29.2

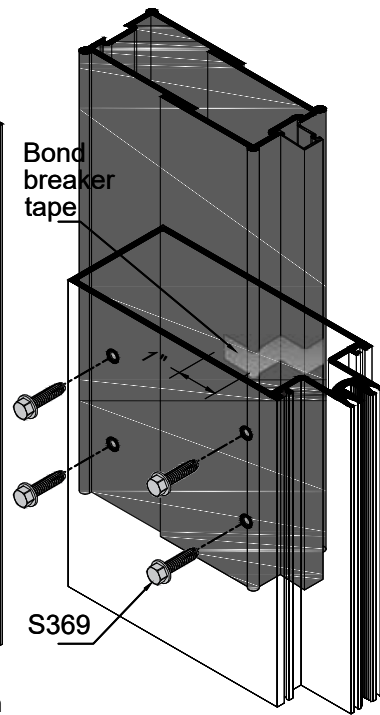

Fig. 29.3

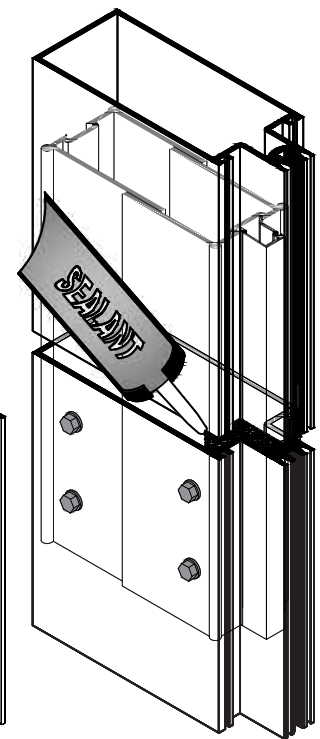

Fig. 29.4

NOTE:
 Flat head screws may be used in vision areas.

NOTE:
 Captured glazing shown,
 SSG splicing is similar.

FRAME FABRICATION

Step 14: Attach Horizontals to Shear Blocks and Anchor Clips

- A. Insert a P1094 ethafoam rod into the void of the tongue of the horizontal members, pushing it about 1/8" past flush to allow room for sealant. See Fig. 30.1.
- B. Seal shear block prior to installing the horizontal member. See Fig. 30.2.
- C. Seal the ends of the horizontal back member and attach to the shear block using S270 screws. Seal the heads of the screws.
- D. Tool sealant at the horizontal/vertical intersection. See Fig. 35.3.

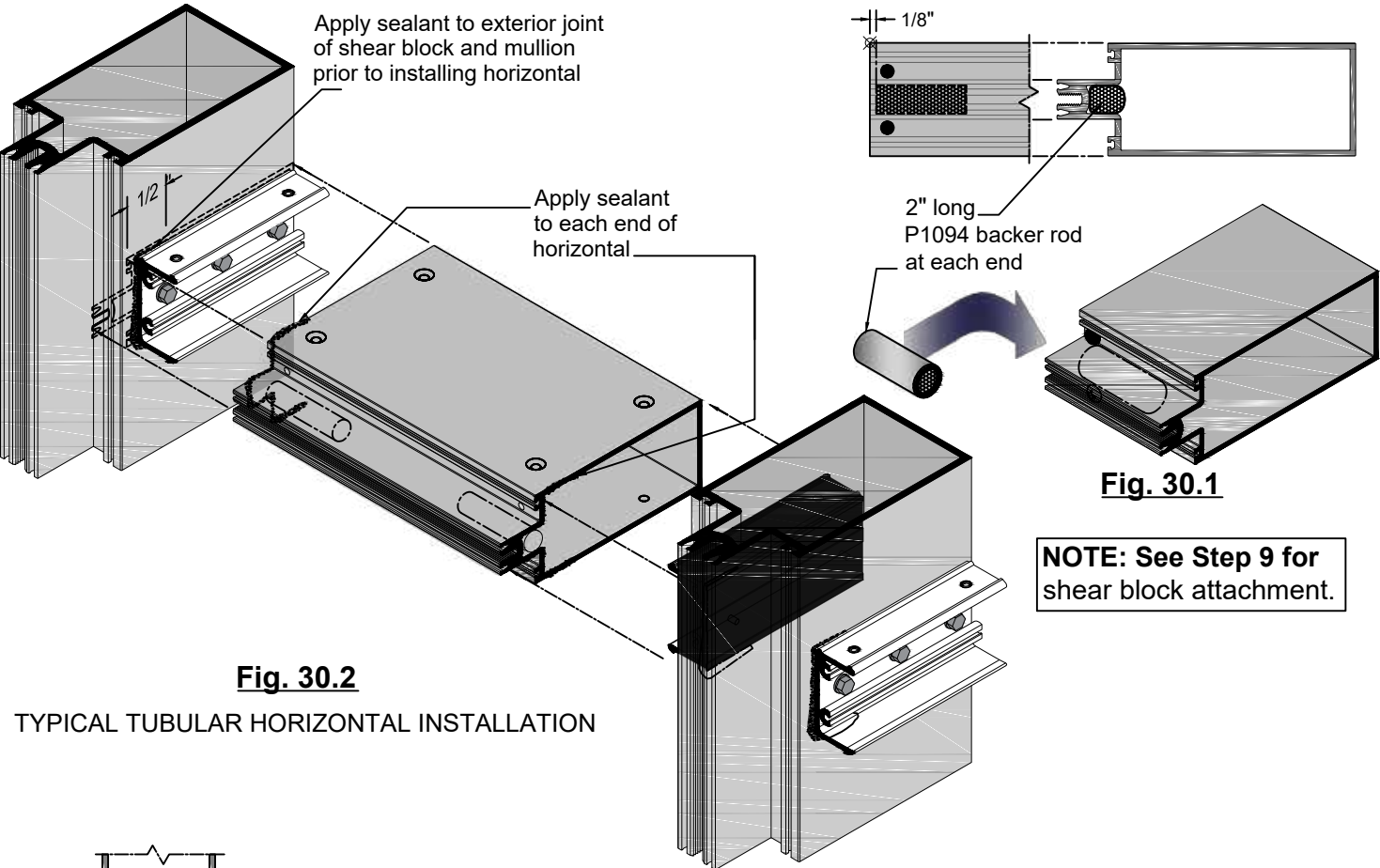

Fig. 30.1

NOTE: See Step 9 for shear block attachment.

Fig. 30.2

TYPICAL TUBULAR HORIZONTAL INSTALLATION

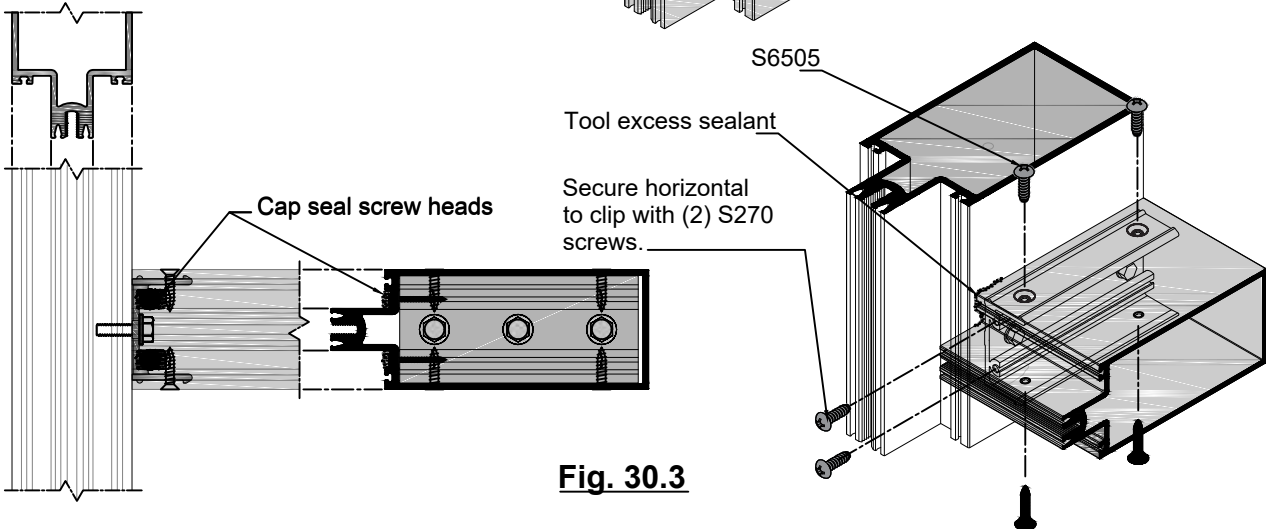
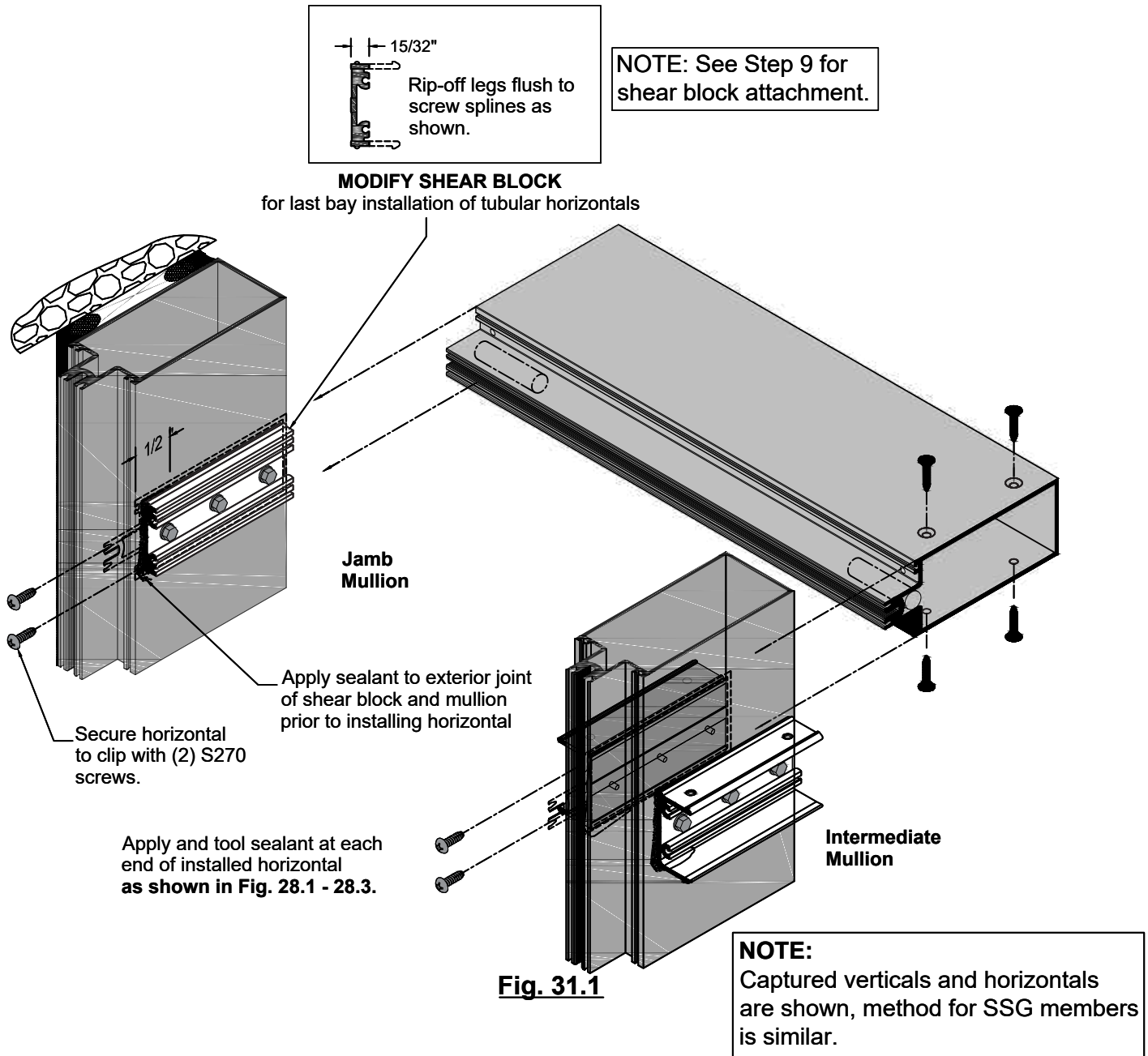

Fig. 30.3

FRAME INSTALLATION

Step 14: Attach Horizontals to Shear Blocks and Anchor Clips (Continued)

LAST BAY TUBULAR HORIZONTAL INSTALLATION



FRAME INSTALLATION

Step 15: Install Water Dams

- A. Seal the end of the horizontal member across the vertical member, including the P1094 ethafoam rod in the tongue of the horizontal. This sealant should be applied liberally.
- B. Push the PTB193 water dam into the void between the horizontal member and the vertical tongue. This is a pressure fit; the water dam should be level with the top of the horizontal tongue.
- C. Seal over the top of the PTB193 onto the horizontal tongue, damming the end of the horizontals. **THIS IS A CRITICAL SEAL.**
- D. For vertical SSG applications, follow the same sealing procedures as with a captured system noted above. See Fig. 32.2.

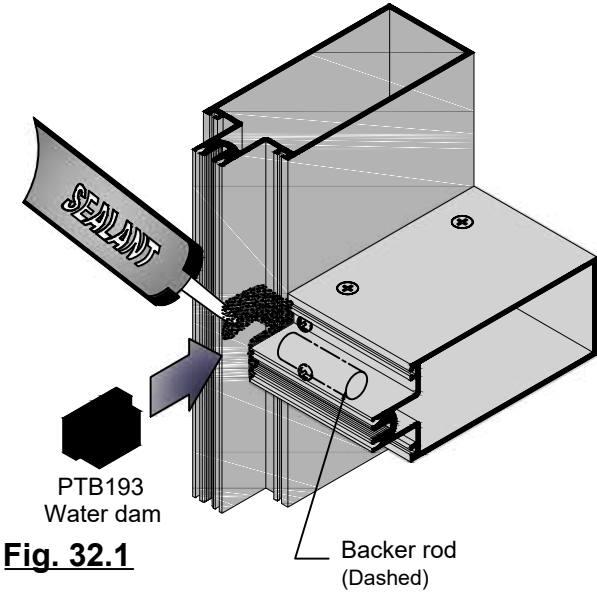
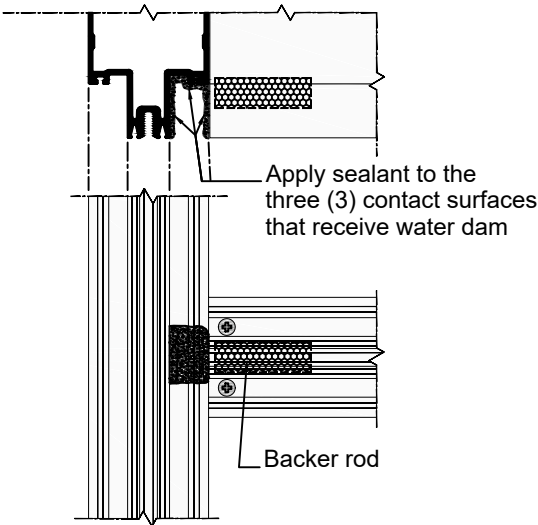

Fig. 32.1

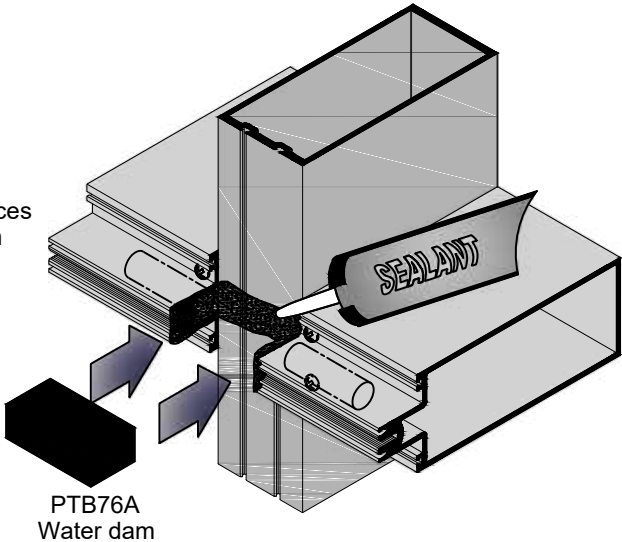
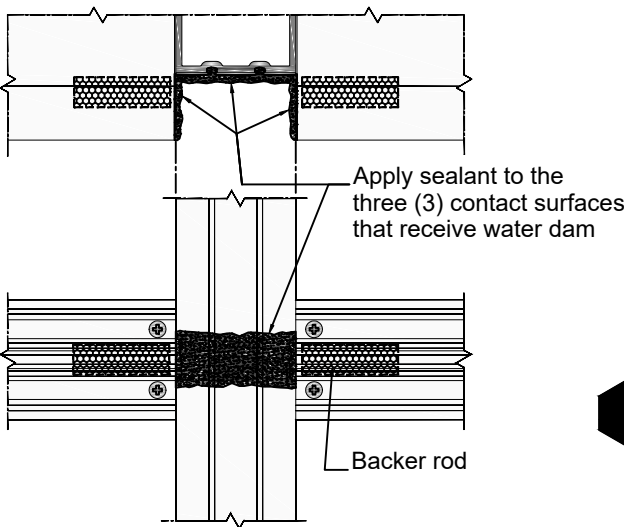
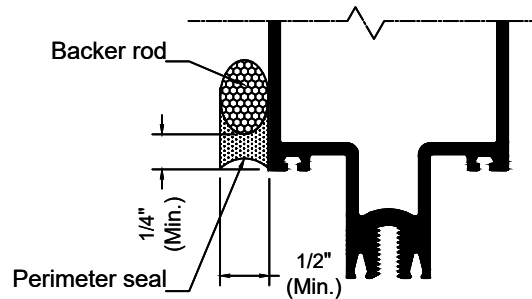

Fig. 32.2

FRAME INSTALLATION

Step 16: Seal Perimeter of Installation

- A. Insert backer rod into the gap between the building substrate and curtain wall frame.
- B. Apply sealant around the perimeter of the frame and tool the sealant. See Fig. 33.1 and Fig. 33.2.



Exterior (shown)
Interior (Similar)

Fig. 33.1

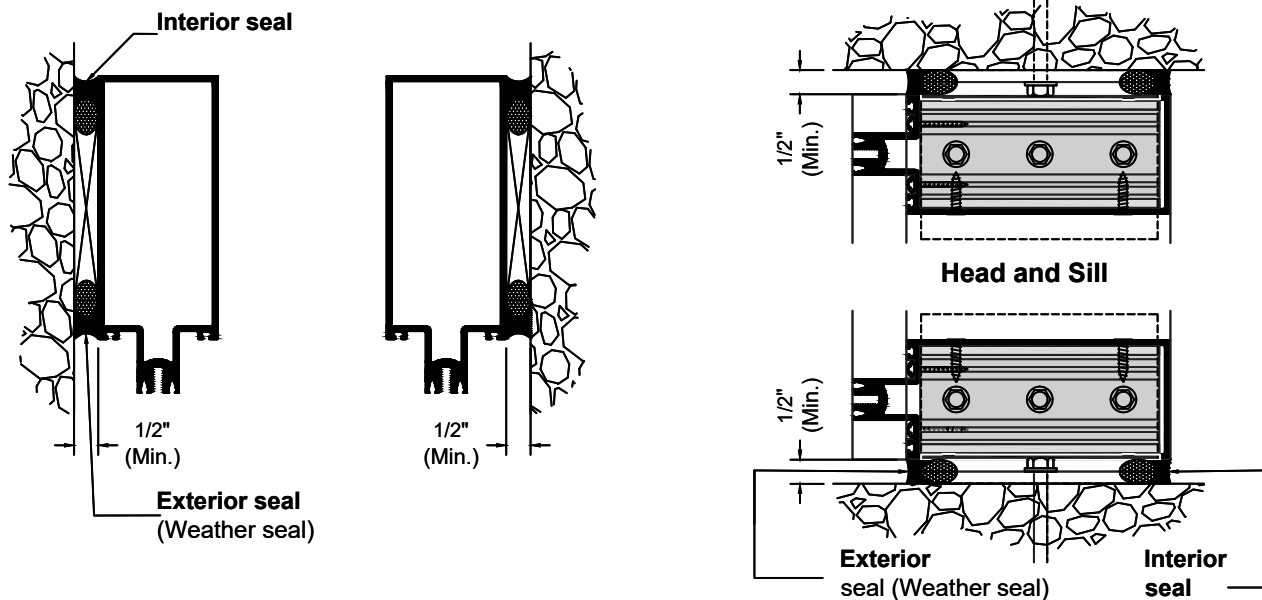

NOTE: Exterior and Interior perimeter seals must run continuous full perimeter of framing.

Fig. 33.2

GLAZING

Step 17: Glazing Preparation

- A. Remove any debris from the glazing pockets.
- B. Trim excess silicone from edges of glazing units to allow for maximum glazing clearance.

Step 18: Install Gaskets

NOTE: Crowd gaskets toward the center of the member during installation to avoid gaps caused by relaxation of the gasket material.

- A. Install PTB28 gasket into vertical and horizontal pressure plates. See Fig. 34.1.

Press gaskets into reglets

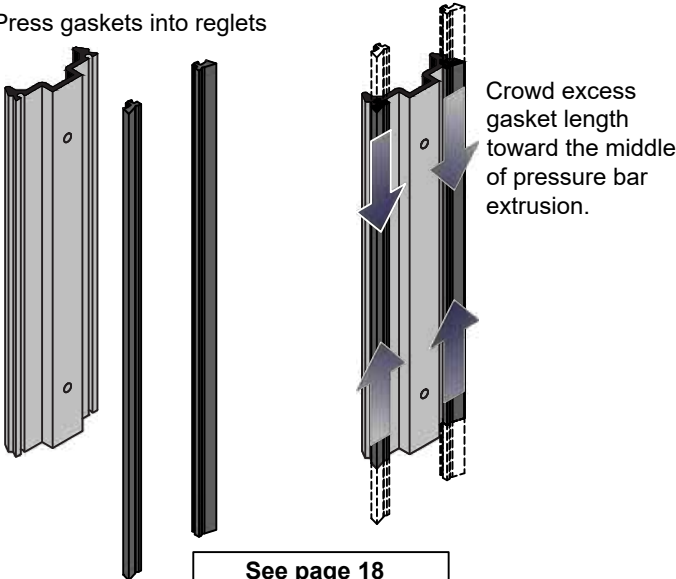

Crowd excess gasket length toward the middle of pressure bar extrusion.

See page 18 for gasket cut lengths

Fig. 34.1

Press P6552 spacers into place

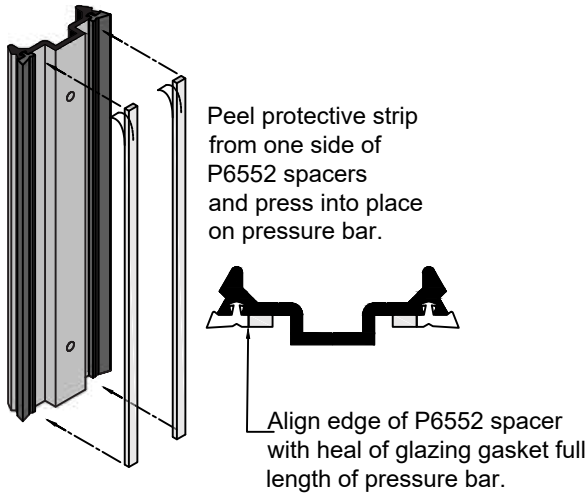

Peel protective strip from one side of P6552 spacers and press into place on pressure bar.

Align edge of P6552 spacer with heel of glazing gasket full length of pressure bar.

Fig. 34.2

PTB106 (SSG)
Modify by removing web from between gasket halves

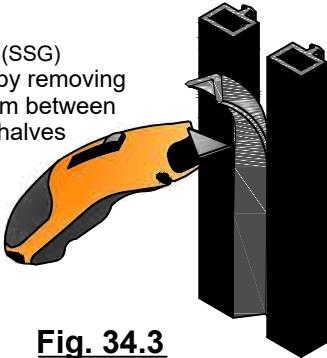

Fig. 34.3

Press gaskets into reglets and crowd excess gasket length toward the middle of extrusion.

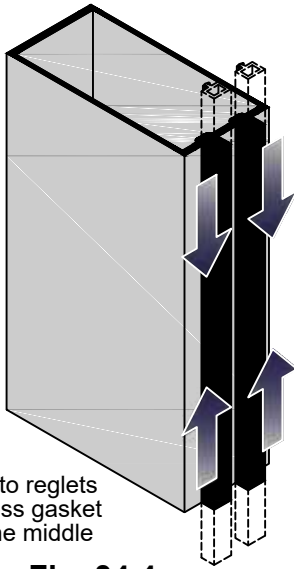

Fig. 34.4

GLAZING

Step 18: Install Gaskets (Continued)

- B. Install P6551, 1/4" x 3/8" tape into vertical mullions. See Fig. 35.1. Vertical spacers run 5/8" beyond the DLO line.
- C. Install P6551, 1/4" x 3/8" tape into the horizontals.
- D. Install PTB94 isolator gasket into vertical and horizontal tongues. Run the isolator through the vertical splice joints.

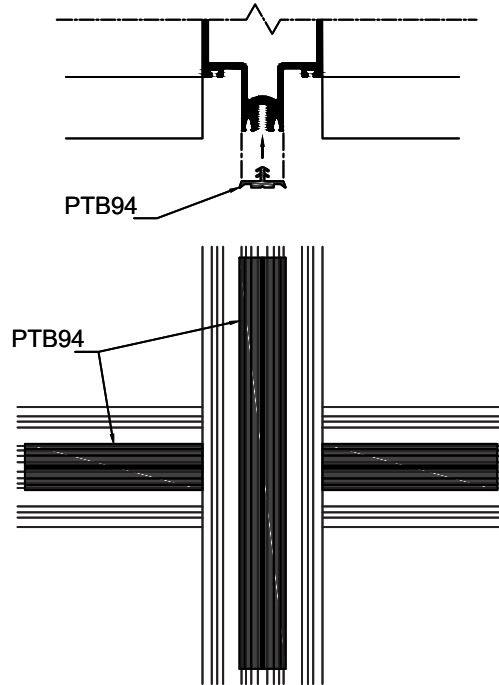

Fig. 35.1

GLAZING

Step 19: Installing Glass

- A. Install two P6550 setting blocks for 1" glass at quarter points or as indicated on approved shop drawings.
Note: Consult glass manufacturer for correct length and location for glass size over 40 sq.ft.

- B. Install glass onto setting blocks, positioning the glass for proper glass bite into vertical mullions. Insert a 1/8" thick shim between the inboard side of the glass and back member to properly space the glass from the mullion to insure proper wet seal thickness. Place shims at top, middle and bottom of the lite. se Fig. 36.2. Make sure the glass is firmly against the shims before installing temporary glazing clips or pressure plates.

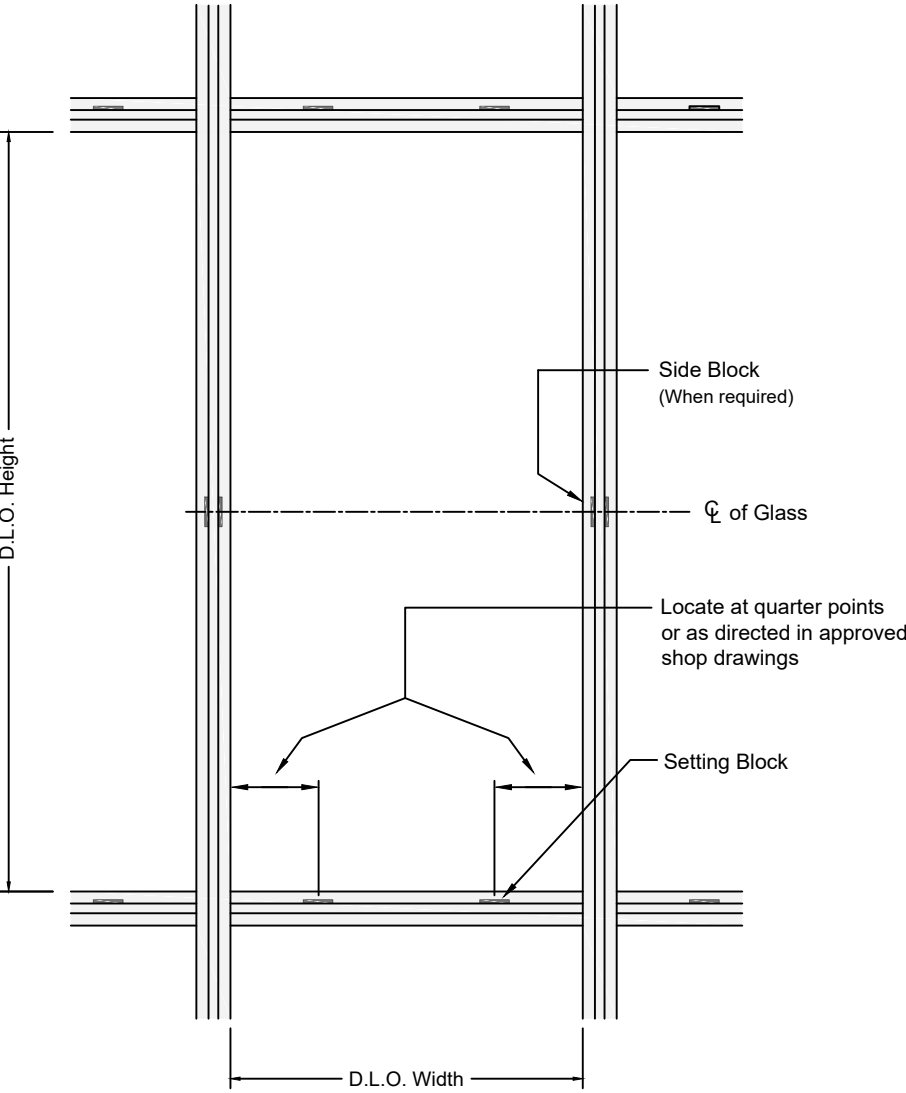

Fig. 36.1

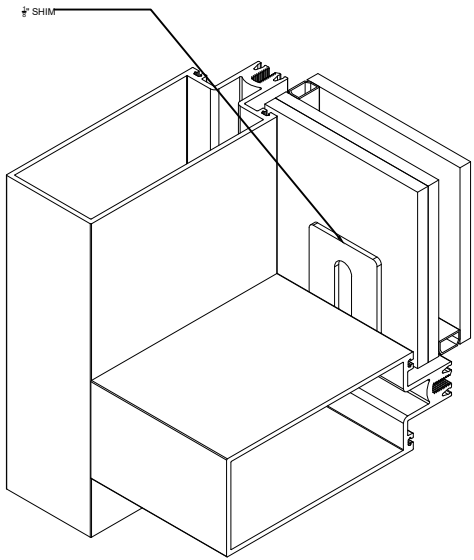

Fig. 36.2

GLAZING

Step 19: Installing Glass (Continued)

- D. Hold the glass in place using P1195 temporary glazing clips. Locate clips near each corner of the glass and at mid points. **Temporary glazing retainers are intended for short term use only. Additional retainers or full length pressure plates may be required if high windload pressures are anticipated before the installation is complete.**

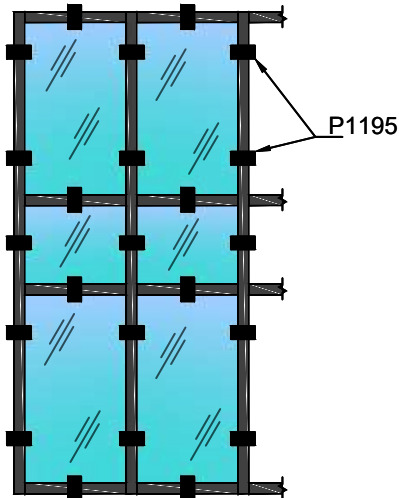

Fig. 37.1

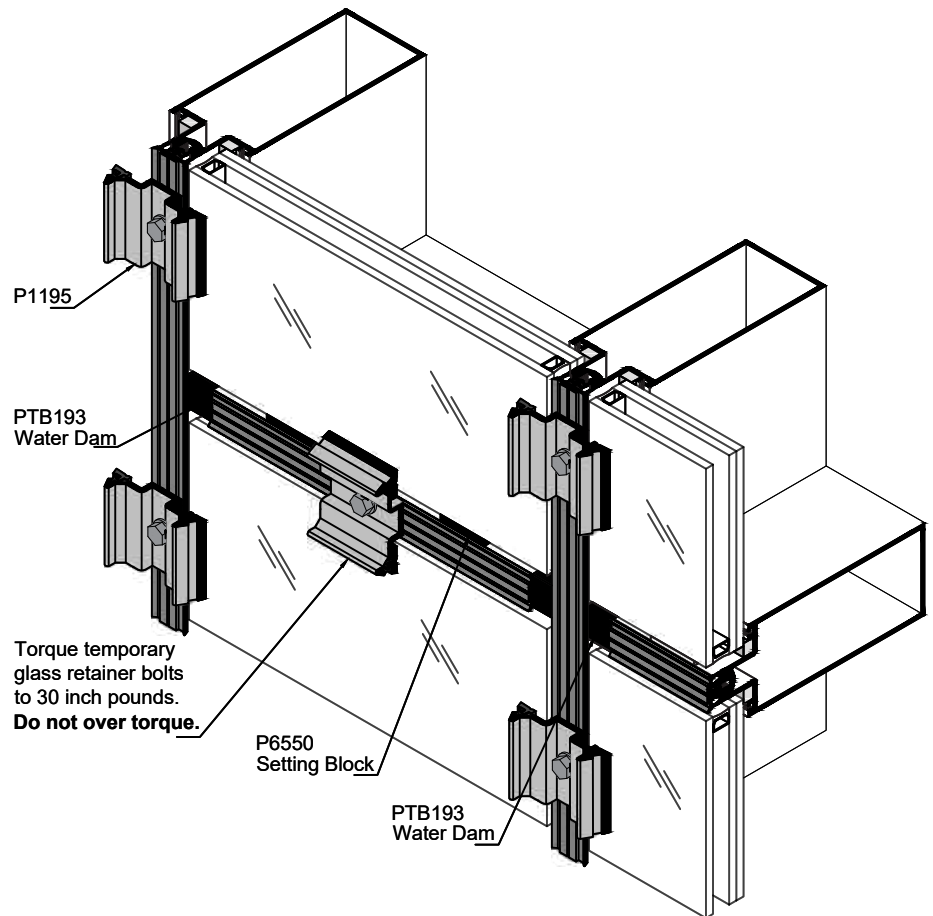

Fig. 37.2

Torque temporary glass retainer bolts to 30 inch pounds. Do not over torque.

NOTE:

For interior dry glazing option, which is available based upon design pressures and glass make up, contact Tubelite.

GLAZING

Step 19: Installing Glass (Continued)

E. Structural silicone is applied from the interior. Hold glass in place with P1195 temporary glazing clips and a 1/4" x 2" TEK screw. Tape off side of vertical and glass prior to applying the structural silicone. Apply sealant around the shims (See Step 19.B, page 36). After the structural silicone has cured per silicone manufacturer's recommendations, remove the shims and P1195 temporary glazing clips. Seal the hole in the mullion from the screw used to attach the P1195 clip prior to applying the pressure plates (Captured system) or weather seal (SSG System).

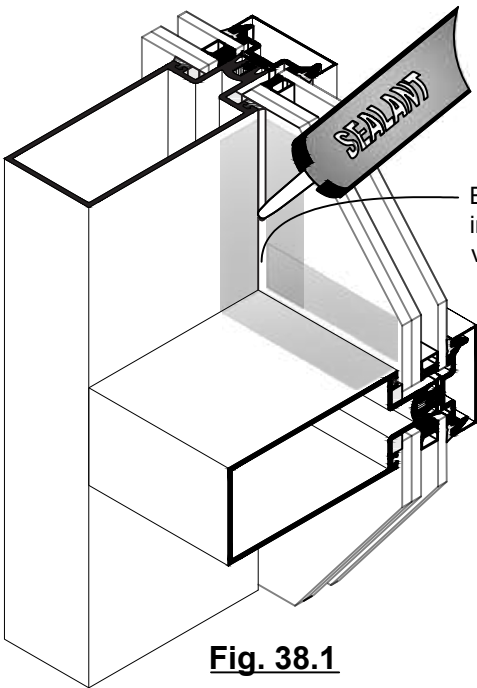

Ensure silicone is injected into voids at horizontal and vertical intersection.

Trim edges of structural silicone area with masking tape for clean lines. Apply silicone and tool.

Fig. 38.1

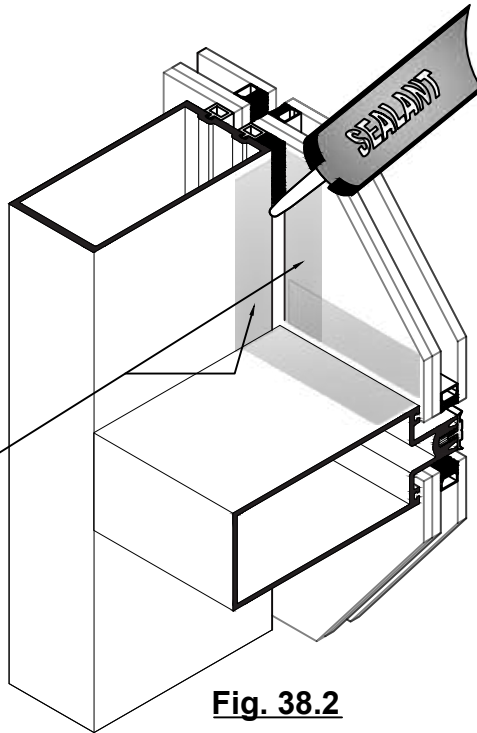
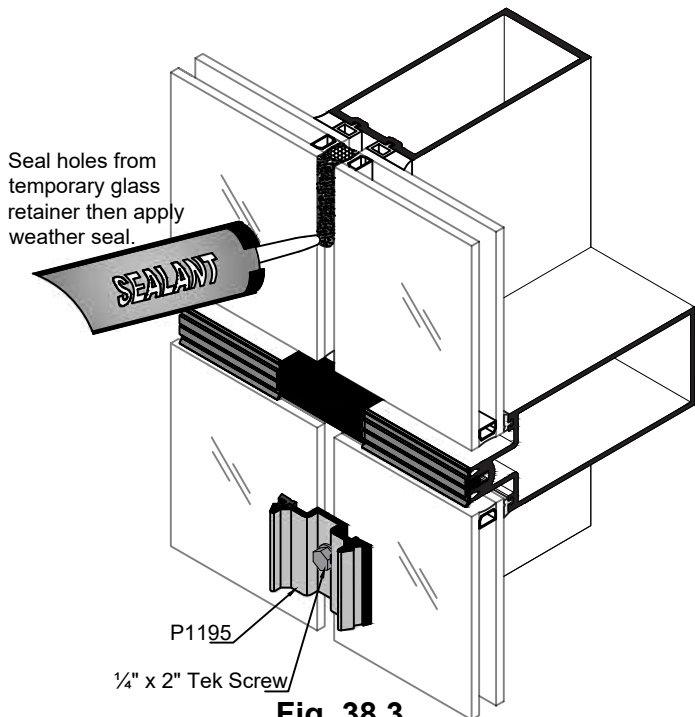

Fig. 38.2



Seal holes from temporary glass retainer then apply weather seal.

P1195
1/4" x 2" Tek Screw

Fig. 38.3

GLAZING

Step 20: Install Pressure Plates and Face Covers

- A. Remove temporary glazing retainers from verticals as required.
- B. Vertical pressure plates must be installed first. Prior to installing, apply sealant to the face of each water dam.
- C. Install the vertical pressure plates using S359 screws.
- D. Remove temporary glazing retainers from horizontals as required.
- E. Install the horizontal pressure plates using S359 screws, ensuring that weep holes are on the top side of the pressure plate.
- F. Ensure there are anchor holes in the pressure plates 2" max from the ends and 2" max from each horizontal/vertical intersection to maintain proper compression on the glass.
- G. Torque all pressure plate screws to 60 in-lbs. When using a cordless drill with a torque limiter, check torque periodically against a torque wrench.
- H. Install the vertical face covers using a wood block to protect the face cover.
- I. Seal the horizontal pressure plates to the vertical face covers, tooling the sealant into the joint.
- J. Install the horizontal face covers with equal gaps on each end. Make sure the weep slots in the face cover are pointing down.

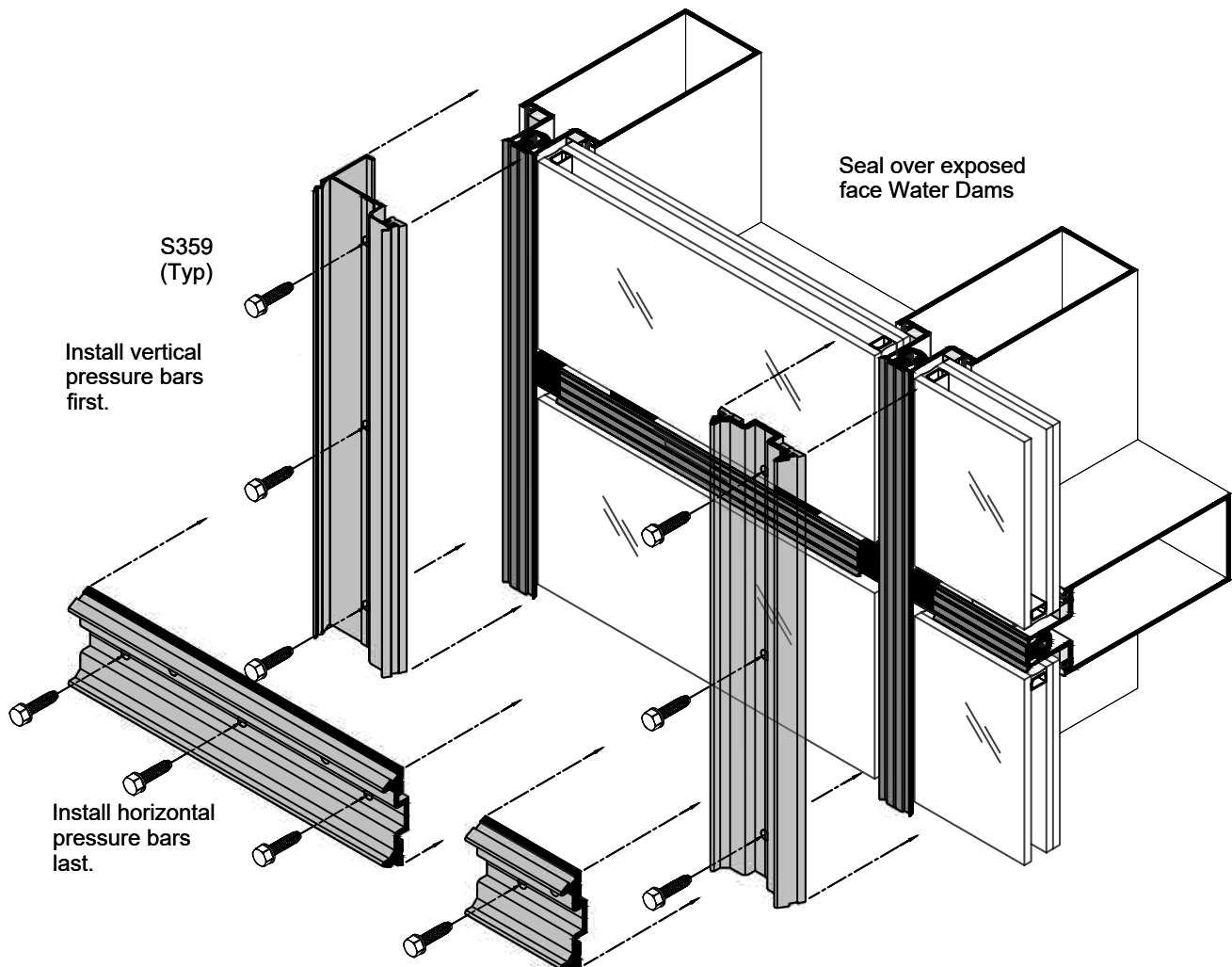

Fig. 39.1
Also see Fig. 38.1.

GLAZING

Step 20: Install Pressure Plates and Face Covers (Continued)

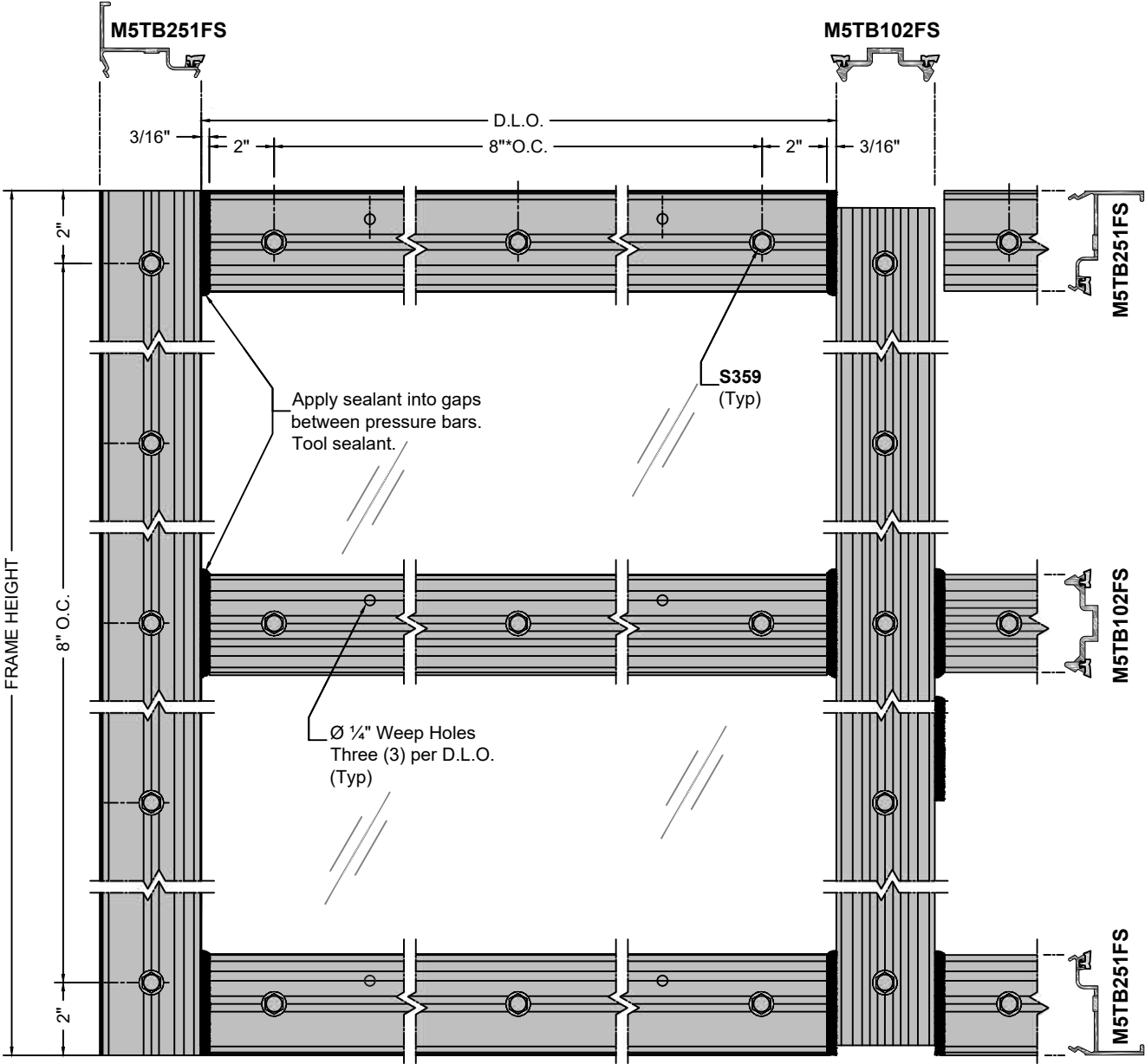

Fig. 40.1
CAPTURED PRESSURE BAR INSTALLATION

Step 20: Install Pressure Plates and Face Covers (Continued)

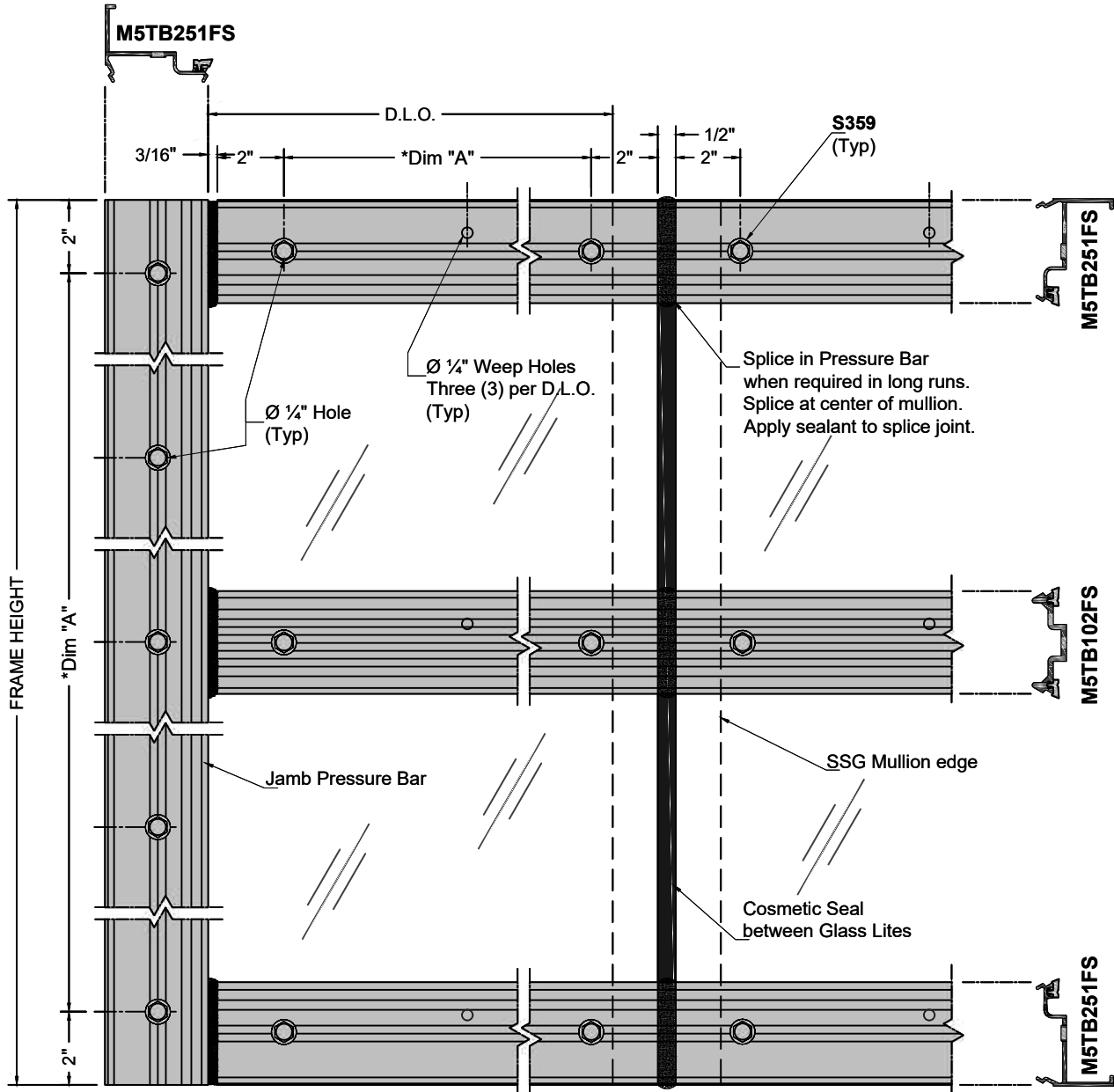

Fig. 41.1

SSG PRESSURE BAR INSTALLATION

NOTE: SSG horizontal not shown

GLAZING

Step 20: Install Pressure Plates and Face Covers (Continued)

- H. Install the vertical face covers using a wood block to protect the face cover.
- I. Seal the horizontal pressure plates to the vertical face covers, tooling the sealant into the joint.
- J. Install the horizontal face covers with equal gaps on each end. Make sure the weep slots in the face cover are pointing down and PTB42 weep baffles are covering the slots.

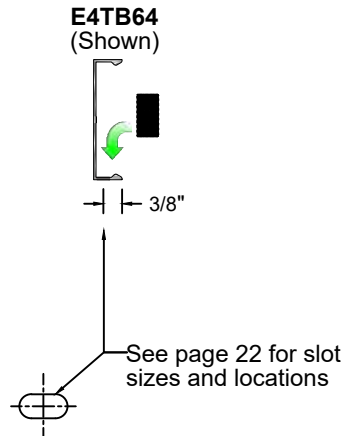
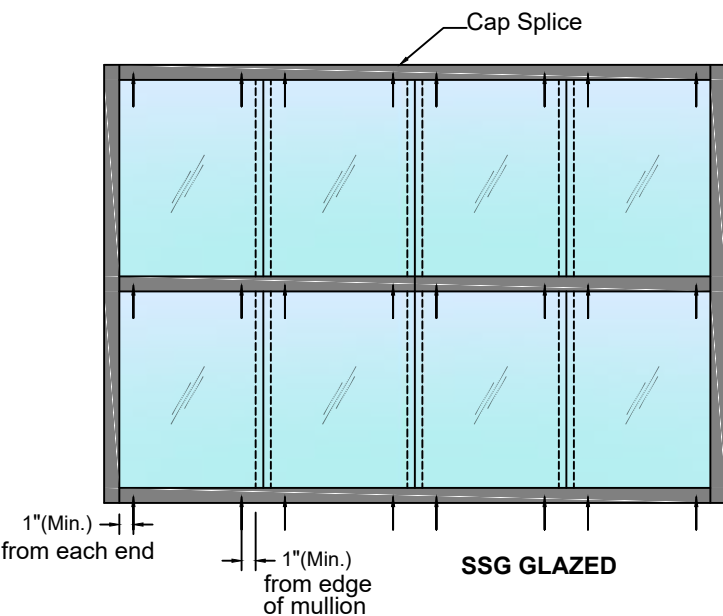
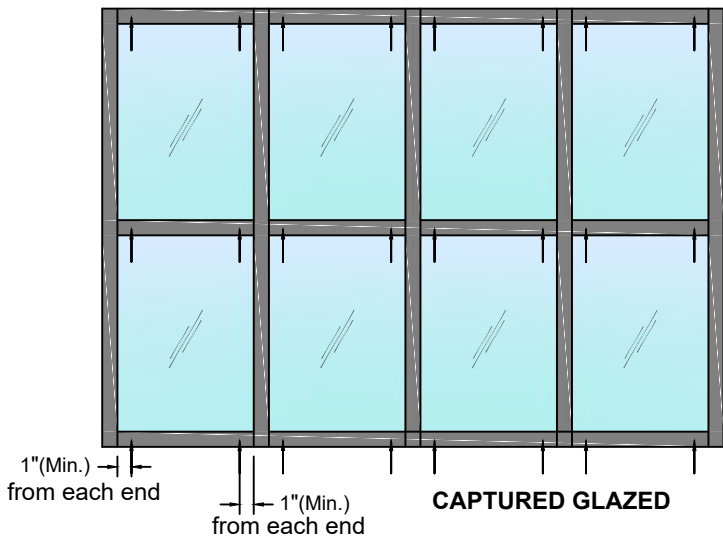

TYPICAL WEEP SLOT
(Located at bottom of horizontal Face Caps)

CUSTOM EXTENDED FACE CAPS
(Available upon request)

Fig. 42.1

GLAZING

Step 20: Install Pressure Plates and Face Covers (Continued)

Seal horizontal pressure bar end gaps.

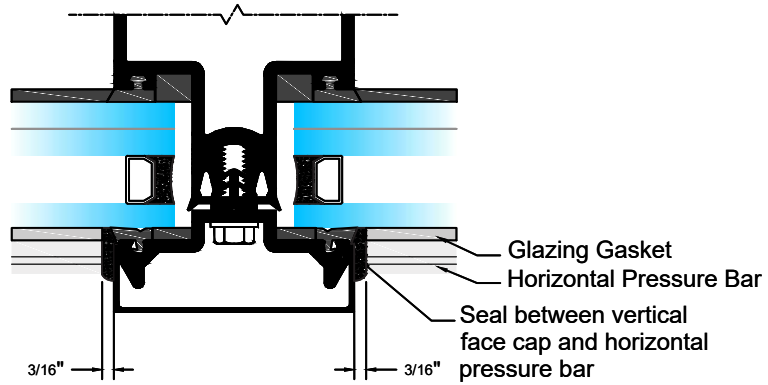

Fig. 43.1

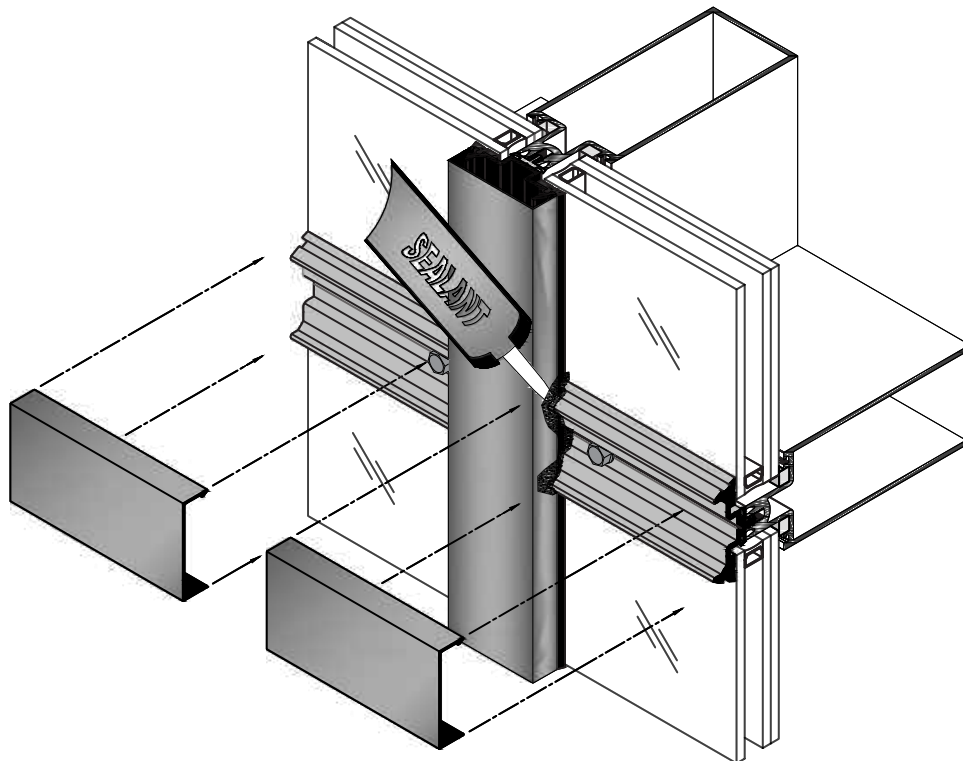

Fig. 43.2

GLAZING

Step 20: Install Pressure Plates and Face Covers (Continued)

Pressure Bar and Face Cap at multi-span mullion splice.

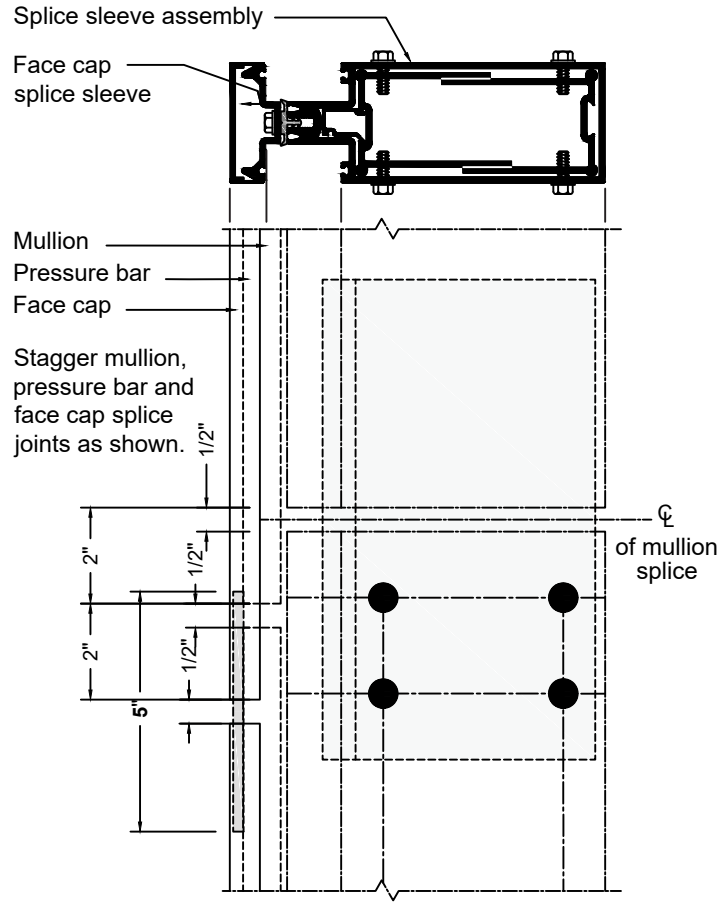

Fig. 44.1

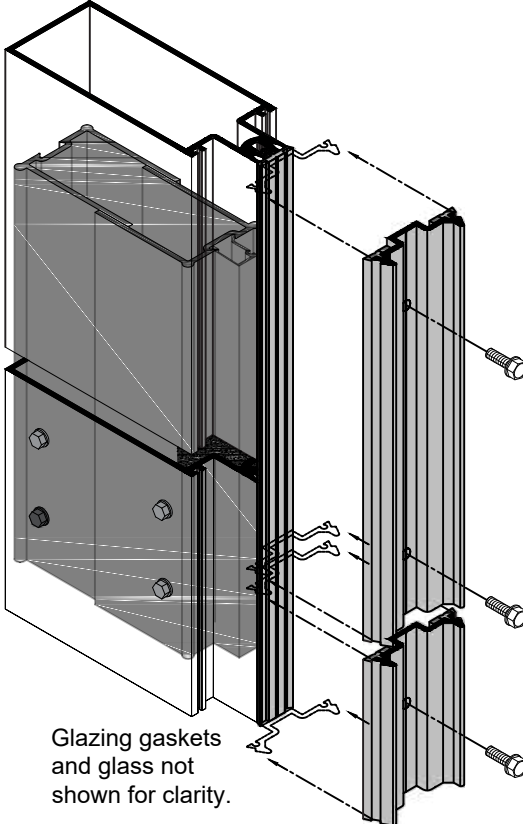

Fig. 44.2

See Step 13 for mullion splice procedure.

GLAZING

Step 20: Install Pressure Plates and Face Covers (Continued)

Pressure Bar and Face Cap at multi-span mullion splice.

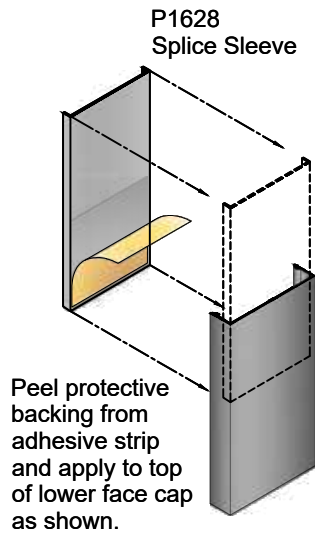

Fig. 45.1

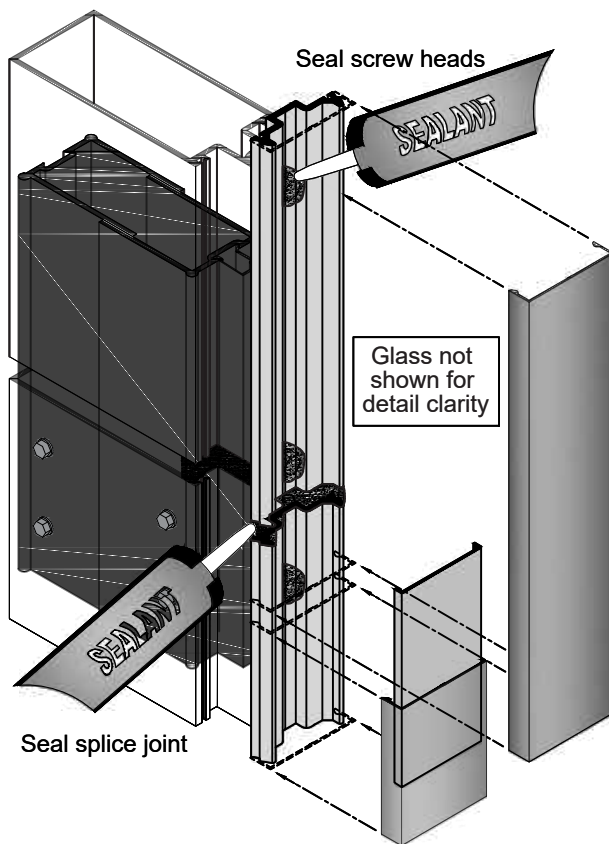

Fig. 45.2

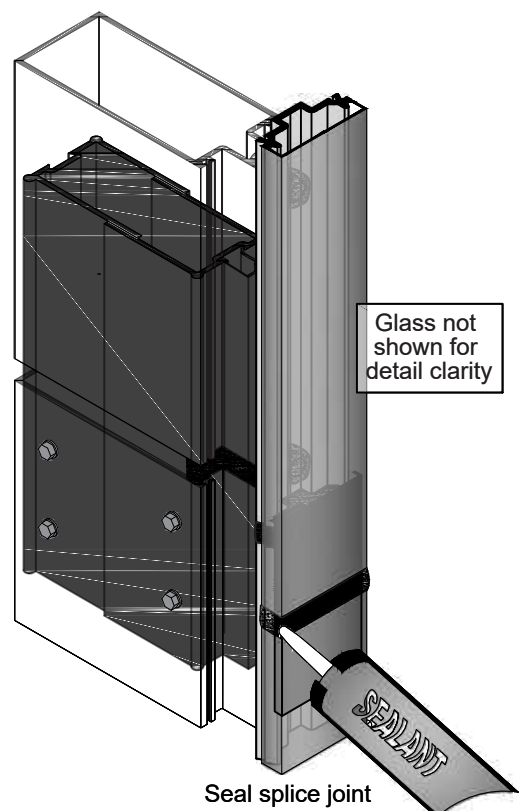

Fig. 45.3

GLAZING

Step 20: Install Pressure Plates and Face Covers (Continued)

Pressure Bar and Face Cap at multi-span mullion splice.

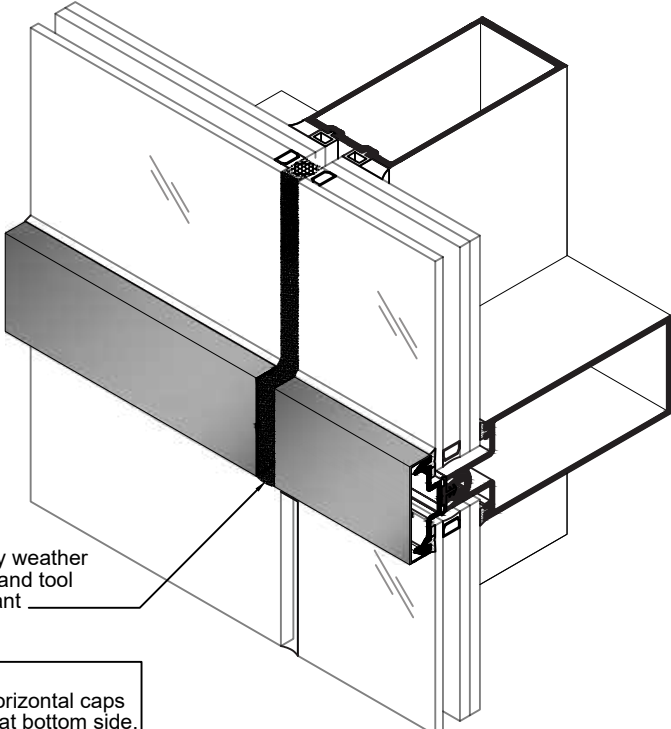

Fig. 46.1

NOTE:
Always place horizontal caps with weep hole at bottom side.

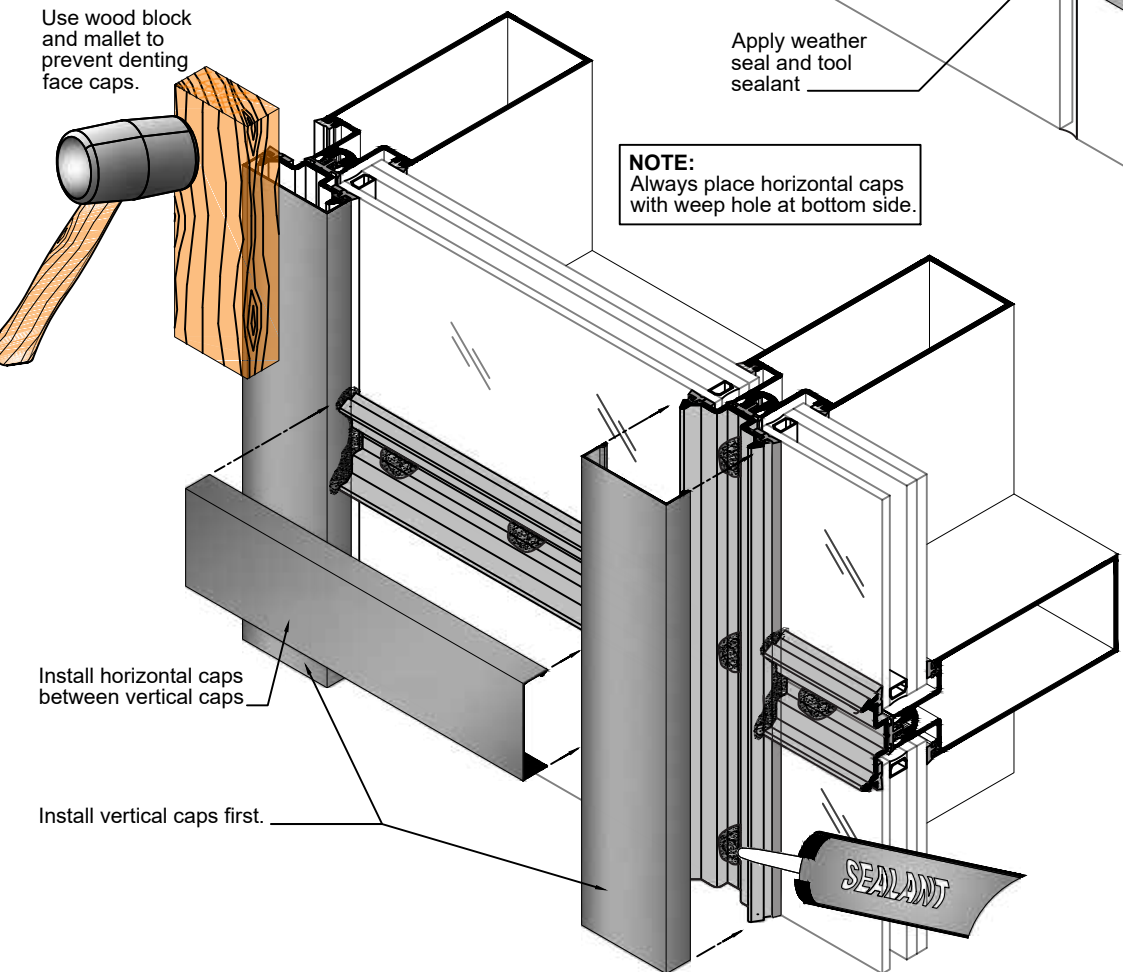

Fig. 46.2

FACE CAP INSTALLATION

ENTRANCE FRAMING

ENTRANCE FRAMING

- A. All door framing is shipped fabricated from the factory. Curtain wall frames can be installed in the field prior to installing the doors.
- B. Curtain wall verticals and door subframes run to floor. Bed verticals in sealant and anchor to building per approved shop drawings. See Fig. 47.1 and Fig. 47.2 for possible anchoring methods.
Always refer to approved shop drawings for specific requirements.

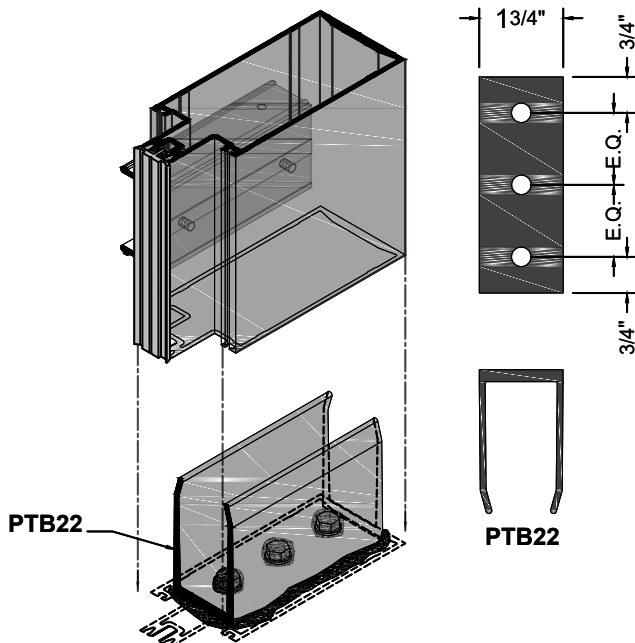
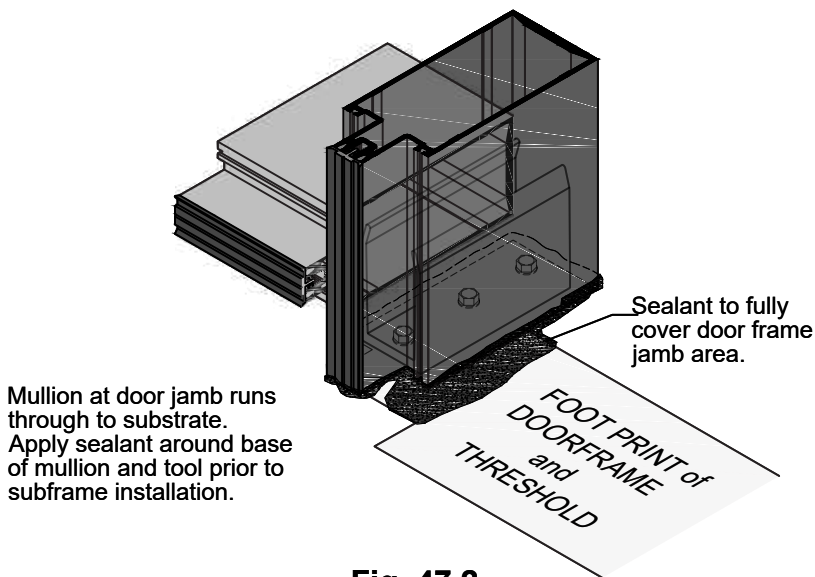

Fig. 47.1



Mullion at door jamb runs through to substrate. Apply sealant around base of mullion and tool prior to subframe installation.

Fig. 47.2

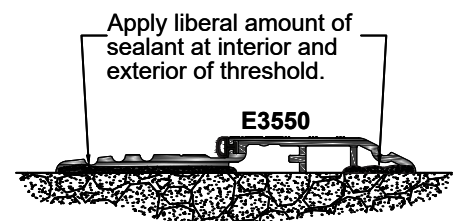

Fig. 47.3

ENTRANCE FRAMING

ENTRANCE FRAMING (Continued)

C. SUBFRAME INSTALLATION

- Prep the curtain wall frame with pocket closures or as detailed on approved shop drawings.
- Prior to installing the subframe, lay down a bed of sealant where the threshold will be installed.
See Fig. 44.2 and Fig. 43.3.
- Install subframe onto curtain wall mullion, shimming equally from side to side. Attach subframe per approved shop drawings. Seal joint between subframe and curtain wall.
- Seal the top of the jamb subframe as shown in Fig. 48.3.
- Attach threshold to building per approved shop drawings.
- Install door per Tubelite’s Entrances and Frames Installation Manual.

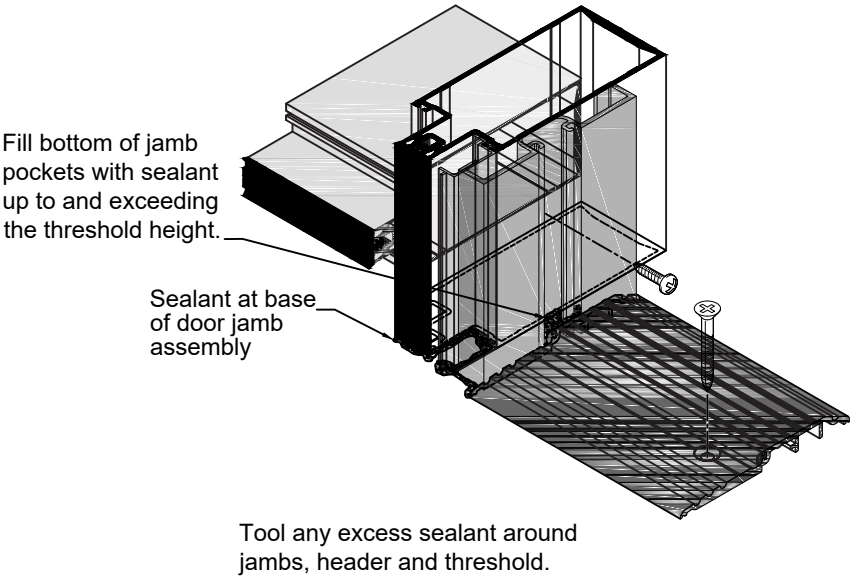

Fig. 48.1

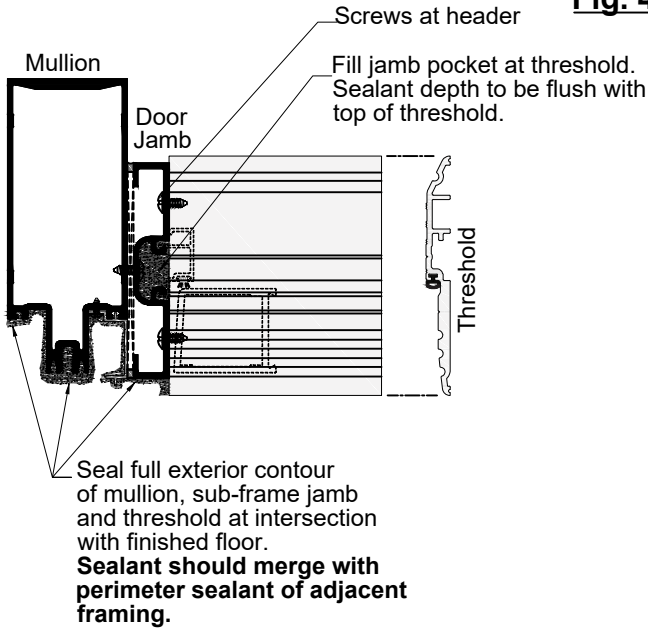

Fig. 48.2

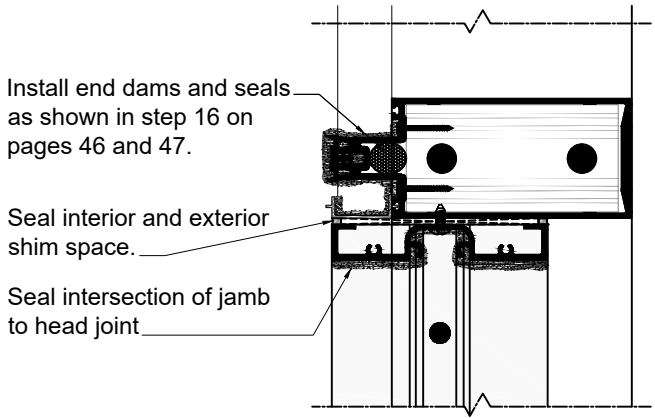

Fig. 48.3

REGLAZING

REGLAZING

- A. Reglazing is done from the exterior.
- B. Carefully remove face covers surrounding the lite to be removed.
- C. Remove vertical and horizontal pressure plates adjacent to affected lite.
- D. Temp surrounding glass in place with P1195 temporary clips per Step 19, pages 46 through 48.
- E. Remove lite of glass and gaskets from opening. Clean debris and sealant from the glass pocket and glazing reglets.
- F. Install new glass in opening per Steps 17 through 19, pages 32 through 40.

CORNER CONDITION

CAPTURED OUTSIDE CORNER

- A. Attach E5TB250FS captured corner adaptor to the back member using “S428”, spaced 18” on center.
- B. Install horizontals to corner mullion.
- C. Install water dams as noted in Step 14, pages 30.
- D. Attach glazing gaskets, spacers and isolator gaskets and seal as noted in steps 18, page 33.
- E. Install glass, pressure plates and face covers per Steps 19 and 20, pages 35 through 41.

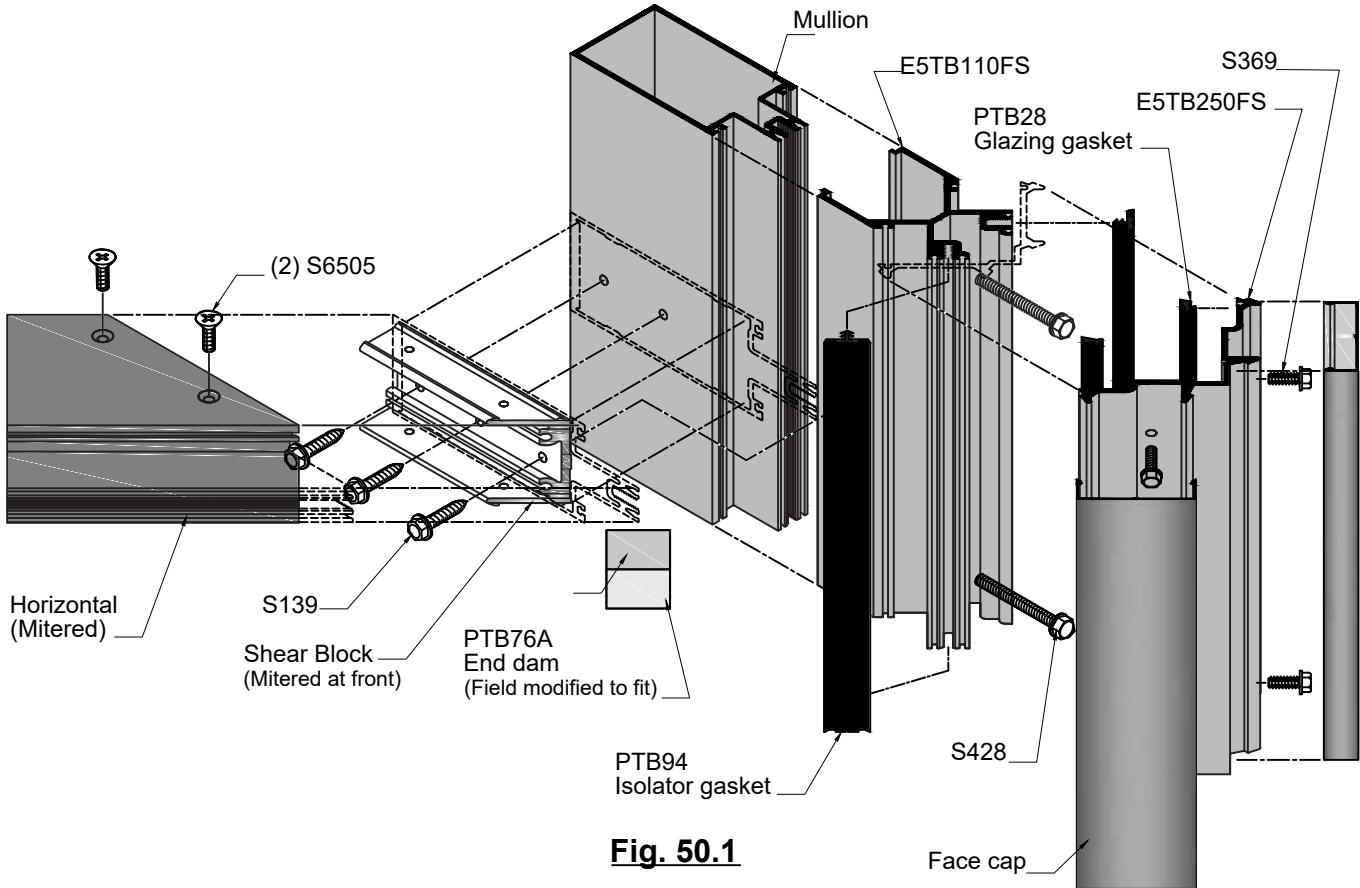
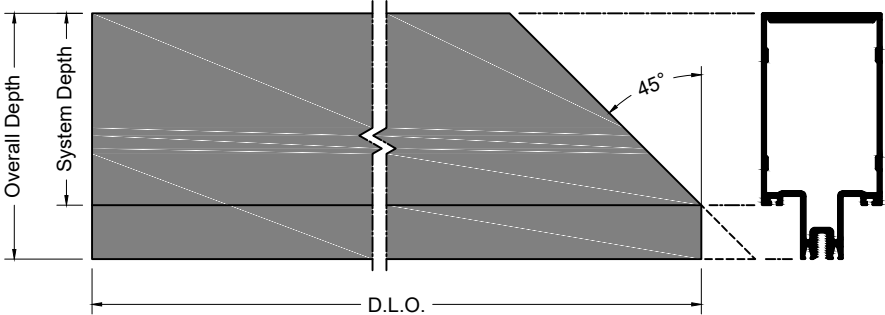

Fig. 50.1



Horizontal at outside 90° corners (Handed)

Fig. 50.2

CORNER CONDITION

SSG OUTSIDE CORNER

- A. Attach E5TB67FS captured corner adaptor to the back member using "S427" , spaced 18" on center.
- B. Install horizontals to corner mullion.
- C. Install water dams as noted in Step 15, pages 32.
- D. Install glazing gaskets, spacers and isolator gaskets and seal as noted in steps 18, page 34 and 35.
- E. Install glass, pressure plates and face covers per Steps 19 and 20, pages 39 through 46.

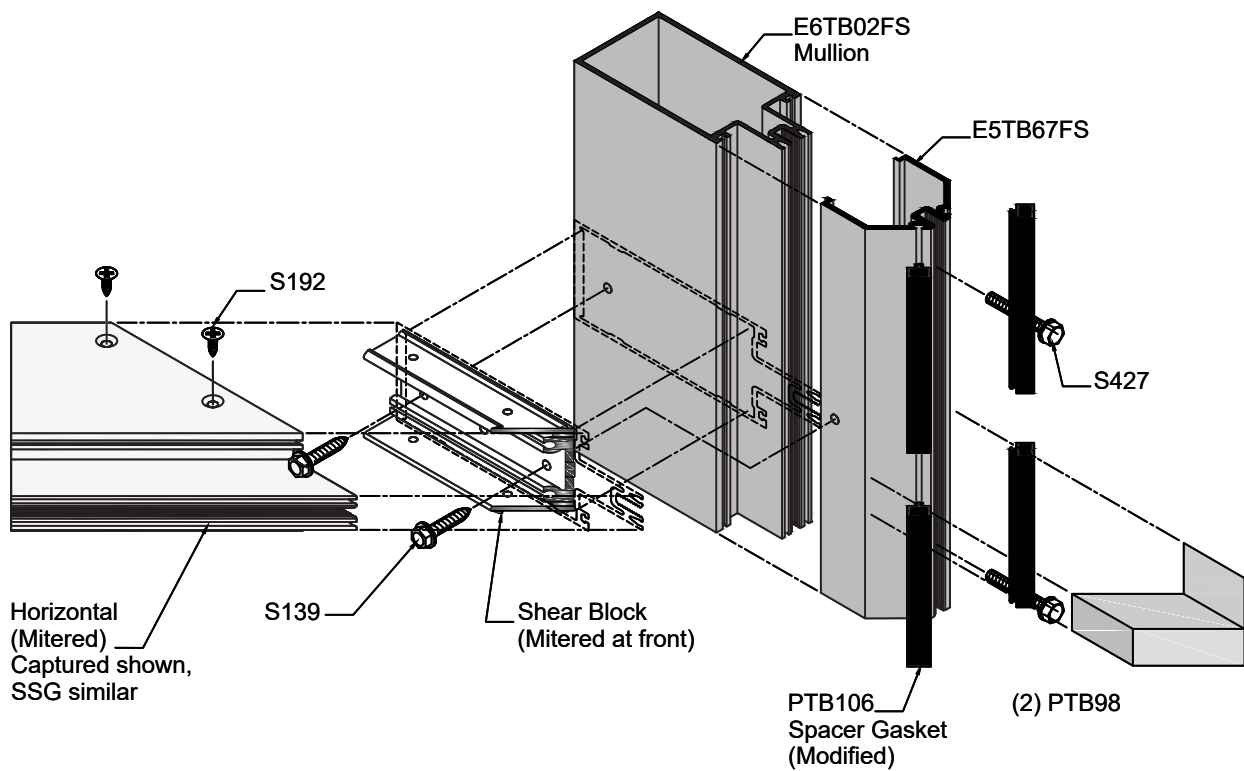

Fig. 51.1