

▼ 4560 Handle

Lever of satin chrome plated zinc alloy is shaped to fit the hand, with a concave thumb-rest portion that tends to keep knuckles and thumb safely away from the jamb, even on a short backset narrow stile. Finish: 682 (US26D).



▼ 4565 Handle

Thumbturn of minimum practical length is designed to offer a firm grip to the fingertips. Ideal for doors where latch is operated infrequently or in emergencies only. Finish: 682 (US26D).

▼ Function

Designed to operate 4500/4700/4900 Series latches by a natural downward hand movement, these handles incorporate an activator cam disc that mounts on the handle escutcheon and fits solidly into the cylinder hole of the latch. Not intended for use as a door pull.

Deadlatch Handles

4560, 4561, 4565

▼ 4561 Handle

Lever of black satin nylon. Shaped similarly to 4560 for convenient, safe operation. Nylon material remains comfortable to the touch even in very hot or very cold environments.

▼ Escutcheons

All three handles shown here use the same 1-3/8" x 4" escutcheon. It is designed to match the narrow stile door's clean lines. A 1/4" square heat-treated spindle is part of escutcheon assembly, which interlocks with the cam plug. Finish: Ritecoat 130.

▼ Cam Plugs

Secured in latch body by cylinder setscrew, plug is also rigidly tied to handle escutcheon by hardened steel pins. Handing can be reversed by removing a spring clip, "flopping" the cam and replacing the clip.



4560/61/65 Deadlatch Handles

DIMENSIONS

INCHES
MILLIMETERS
Nominal, subject to tolerance extremes.

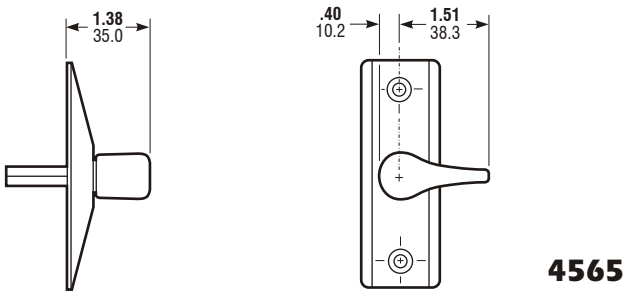
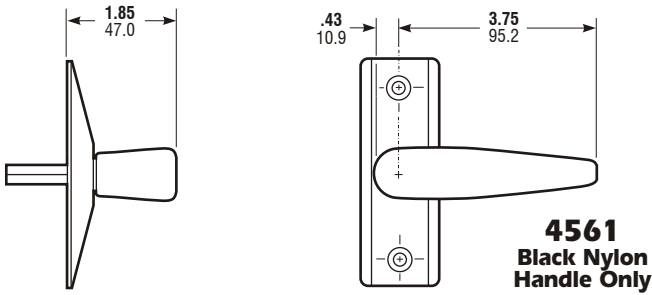
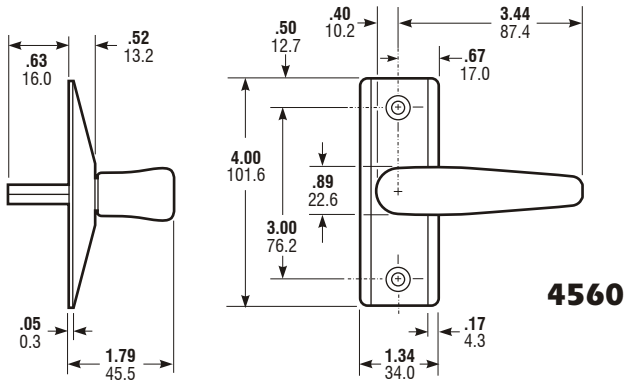

HOW TO ORDER

Specify quantity and the following information.
Specify special Ritecoat finish if required. See page SW-33.

Handle Type

- 4560** Satin
- 4561** Nylon
- 4565** Turn

Handing*

- 5** LH or LHR
- 6** RH or RHR

Door Thickness For MS+1890

- 11** 1-3/4"
- 12** 2" - 2-1/4"
- 13** 2-1/2" - 2-3/4"
- 14** 3"

4560-501-130

Door Thickness For 4500/4700/4900

- 01** 1-3/4" - 2"
- 02** 2-1/4" - 2-1/2"
- 03** 2-3/4" - 3"
- 04** 3-1/4"

Finish

- 130** Satin Aluminum
- 121** Dark Bronze
- 119** Black

*Assuming handle on interior of door.

INSTALLATION

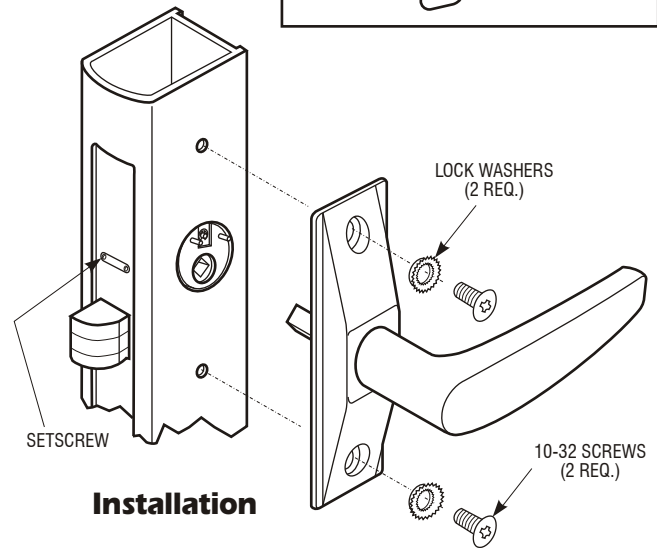
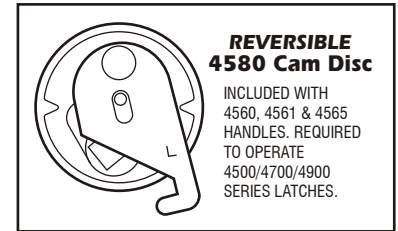
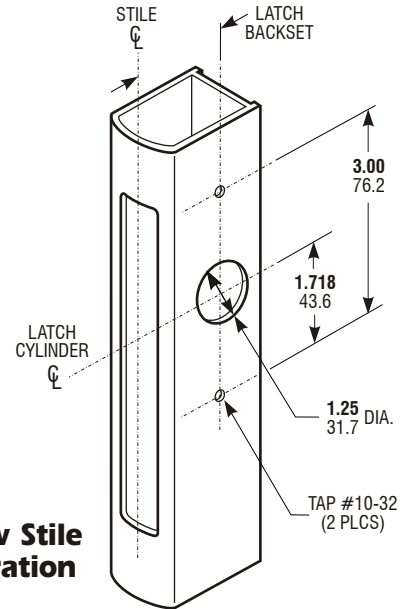

OPTIONS

Pre-handing can be specified LH or RH although re-handing in the field is easily accomplished. The three standard handles shown are for 1-3/4" thick doors. Available on special order for doors up to 3-1/4" at extra cost.

STANDARD PACKAGE

Individually bagged and bulk-packed in cartons, up to 100 per carton.