





Maxblock™ Sunshades by Tubelite

Designed for use with Tubelite 200 & 400 Series Curtainwall (Shear Block & Screw Spline)

Airfoil Blade System

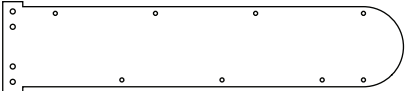
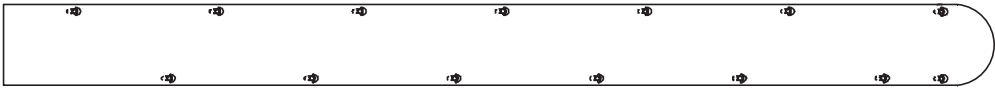
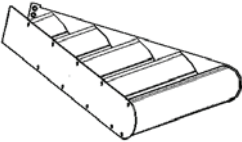
Illustration	Part Number	Description	Base List Price	Weight / S.L.	Ft./ S.L.	Stocked			
						Mill	Clear	Bronze	White
	E3902	5" Airfoil Blade	\$ 176	24.47	21'0"	-			
	E3901	Radiused Fascia	\$ 147	17.66	21'0"	-			
	P3901A*	20" Outrigger - use 3 Blades	\$ 83	-	-	-			
	P3901B*	25" Outrigger - use 4 Blades	\$ 95	-	-	-			
	P3901C*	30" Outrigger - use 5 Blades	\$ 119	-	-	-			
	P3901D*	35" Outrigger - use 6 Blades	\$ 133	-	-	-			
		<i>Corner outriggers are 50" length and must be cut to fit. Use [1] each Right and Left halves per corner. The assembly is shown with P3901B & P3905 Outriggers, [4] Blades and Fascia.</i>							
	P3905L*	Outrigger for 90 degree corners - Left half	\$ 204	-	-	-			
	P3905R*	Outrigger for 90 degree corners - Right half	\$ 204	-	-	-			
	P3909	Fixture for 45 degree miter cut of Airfoil Blade at corner condition	\$ 14	-	-	-			



Please note that many of these extrusions are not stocked and require extra lead-time.



*Outriggers are PAINTED ONLY to match Anodized & Painted finishes, and are subject to related multipliers and set-up charges.

For finishes to match anodized, use KP paint code and finish multiplier with set-up charges for the corresponding anodized finish.

Maxblock™ Sunshades by Tubelite

Designed for use with Tubelite 200 & 400 Series Curtainwall (Shear Block & Screw Spline)

Round Blade System

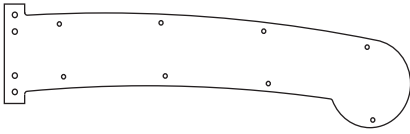
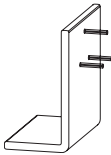
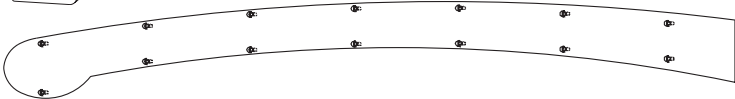
Illustration	Part Number	Description	Base List Price	Weight / S.L.	Ft./ S.L.	Stocked			
						Mill	Clear	Bronze	White
	E3904	2-3/4" Round Blade	\$ 143	20.12	21'0"	-			
	E3906	3-3/4" Round Fascia	\$ 202	28.46	21'0"	-			
	P3904A*	20" Outrigger - use 3 Blades	\$ 120	-	-	-			
	P3904B*	25" Outrigger - use 4 Blades	\$ 138	-	-	-			
	P3904C*	30" Outrigger - use 5 Blades	\$ 171	-	-	-			
	P3904D*	35" Outrigger - use 6 Blades	\$ 185	-	-	-			
	P3911	Fixture for 45 degree mitre cut of Tubular Blade	\$ 14	-	-	-			
	P3912*	Outrigger for 90 degree Corners	\$ 882	-	-	-			

Corner outriggers are 50" length and must be cut to fit.
 Use [1] each Right and Left halves per corner.







Please note that many of these extrusions are not stocked and require extra lead-time.

*Outriggers are PAINTED ONLY to match Anodized & Painted finishes, and are subject to related multipliers and set-up charges. For finishes to match anodized, use KP paint code and finish multiplier with set-up charges for the corresponding anodized finish.

Maxblock™ Sunshades by Tubelite

Designed for use with Tubelite 200 & 400 Series Curtainwall (Shear Block & Screw Spline)

'Z' Blade System

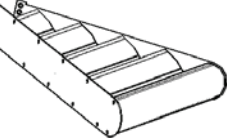
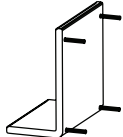
Illustration	Part Number	Description	Base List Price	Weight / S.L.	Ft./ S.L.	Stocked			
						Mill	Clear	Bronze	White
	E3903	5-1/4" 'Z' Blade	\$ 155	18.29	21'0"	-			
	E3905	Box Fascia	\$ 260	21.25	21'0"	-			
	P3903A*	20" Outrigger - use 3 Blades	\$ 83	-	-	-			
	P3903B*	25" Outrigger - use 4 Blades	\$ 95	-	-	-			
	P3903C*	30" Outrigger - use 5 Blades	\$ 119	-	-	-			
	P3903D*	35" Outrigger - use 6 Blades	\$ 133	-	-	-			
		<i>Corner outriggers are 50" length and must be cut to fit. Use [1] each Right and Left halves per corner. The assembly is shown with P3901B & P3907 Outriggers, [4] Blades and Fascia.</i>							
	P3907L*	Outrigger for 90 degree corners - \$ 204 Left half		-	-	-			
	P3907R*	Outrigger for 90 degree corners - \$ 204 Right half		-	-	-			
	P3910	Fixture for 45 degree mitre cut of 'Z' Blade	\$ 14	-	-	-			



Please note that many of these extrusions are not stocked and require extra lead-time.





*Outriggers are PAINTED ONLY to match Anodized & Painted finishes, and are subject to related multipliers and set-up charges.

For finishes to match anodized, use KP paint code and finish multiplier with set-up charges for the corresponding anodized finish.

Maxblock™ Sunshades by Tubelite

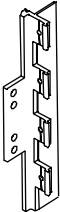
Designed for use with Tubelite 200 & 400 Series Curtainwall (Shear Block & Screw Spline)

Accessories - use section F1 multiplier

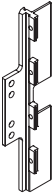
Illustration	Part Number	Description	Per Unit	Base List Price	Stocked			
					Mill	Clear	Bronze	White
	P3900	400CW Anchor Bracket - Self-mating and Interlocking Halves	Each	\$29.00	•			
	P3902	400CW Anchor Bracket - Return Leg for End/Jamb Self-mating and Interlocking Halves	Each	\$29.00				
	P3919	Reinforcing Bar Use with S359	Each	\$19.00				
	S359	1/4-20 x 1 1/2" Hex Washer Head - Tek screw Zinc Fastener for anchor bracket attachment with reinforcing bar	100 per pkg.	\$17.00	•			
	S365	3/8-16 x 5/8" SS Hex Phillips Head ms Zinc Fastener for outrigger attachment to anchor bracket.	100 per pkg.	\$71.00	•			
	S269	#10 x 1" Type 23 S.S. Hex Drive Fastener blade attachment to outrigger.	100 per pkg.	\$71.00	•			
	P3908	200CW Anchor Bracket Self-mating and Interlocking		\$ 33.00				
	S363	1/4-14 x 1-1/2" Hex Head Self-drilling Fastener for anchor bracket attachment to verticals	100 per pkg.	\$17.00				





Please note that many of these extrusions are not stocked and require extra lead-time.

Maxblock™ Sunshades by Tubelite

Designed for use with Tubelite 200 & 400 Series Curtainwall (Shear Block & Screw Spline)

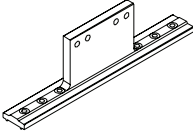
Accessories - use section F1 multiplier

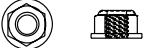
Illustration	Part Number	Description	Weight / S.L.	Ft./ S.L.	Per Unit	Base List Price	Stocked			
							Mill	Clear	Bronze	White
	P3906	200CW Anchor Bracket Return leg for end/jamb Self-mating and Interlocking				\$27.00				
	P3916	400CW - SS IG / 14000 Storefront Sunshade Anchor Bracket (requires 1/4" reduced glass width - see detail)			Each	\$100.00				
	P3918	Reinforcing Bar			Each	\$13.00				
	S367	Bolt for P3916			100/bx.	\$133.00				
	S368	Locking Nut for S367			100/bx.	\$45.00				



Please note that many of these extrusions are not stocked and require extra lead-time.

