

# **400 I.G. Series Curtainwall**

## **Installation Instructions**

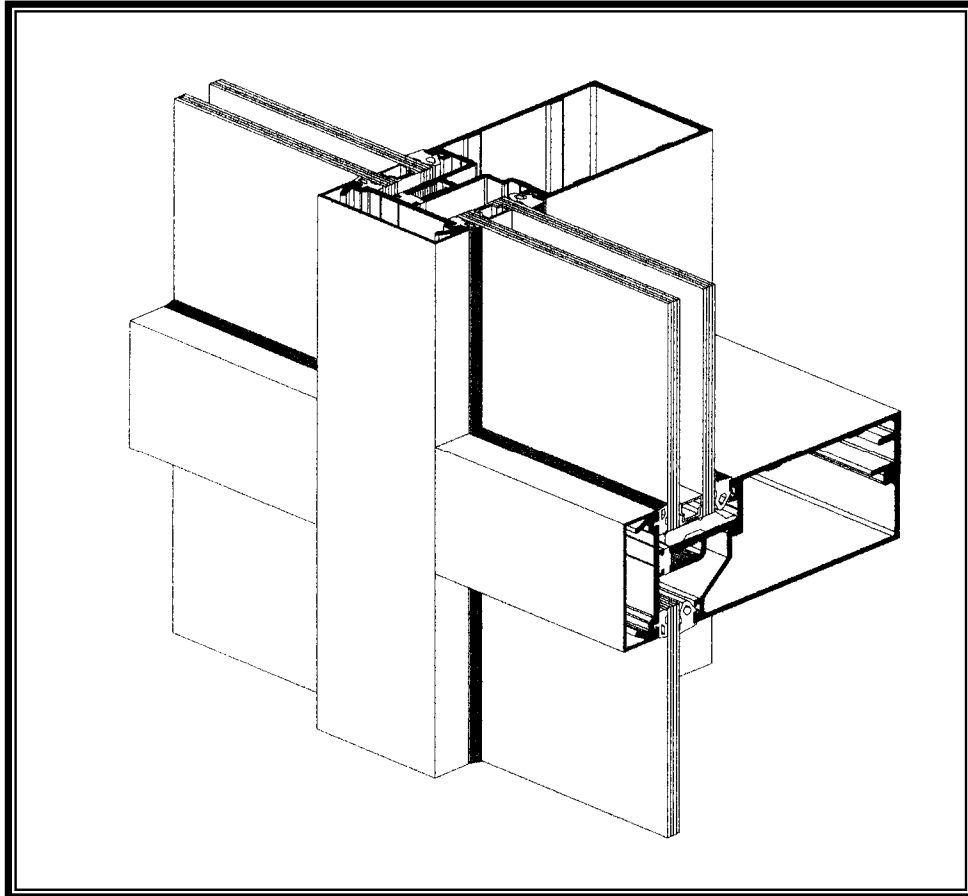

P1891 Rev. 9/20/96

# **TUBELITE<sup>®</sup>**











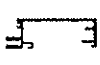

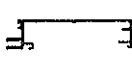

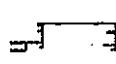
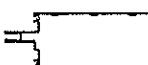
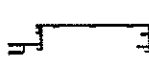

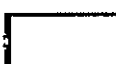
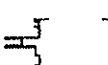

STOREFRONT, CURTAINWALL & ENTRANCES

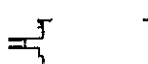
***DEPENDABLE***

---

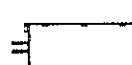
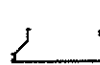

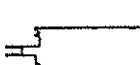















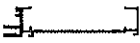

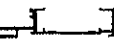

**Tubelite Inc.**  
3056 Walker Ridge Drive NW, Suite G  
Walker, Michigan 49544  
Phone 800.866.2227  
Fax 877.299.2414  
[www.tubeliteinc.com](http://www.tubeliteinc.com)

PARTS LIST - EXTRUSION

DESCRIPTION	PART NO.	DESCRIPTION	PART NO.
 2 1/2" X 3 5/8" TYPICAL MULLION 1/4" GLAZING	E-3400	 3 5/8" INSIDE GLAZE ROLL OVER HORIZONTAL 1/4" GLAZING	E-3412
 2 1/2" X 5 1/4" TYPICAL MULLION 1/4" GLAZING	E-3401	 5 1/4" INSIDE GLAZE ROLL OVER HORIZONTAL 1/4" GLAZING	E-3413
 2 1/2" X 3 5/8" TYPICAL MULLION 1" GLAZING	E-3402	 3 5/8" INSIDE GLAZE ROLL OVER HORIZONTAL 1" GLAZING	E-3414
 2 1/2" X 5 1/4" TYPICAL MULLION 1" GLAZING	E-3403	 5 1/4" INSIDE GLAZE ROLL OVER HORIZONTAL 1" GLAZING	E-3415
 2 1/2" X 3 5/8" OPEN BACK HEAD/JAMB 1/4" GLAZING	E-3404	 2 1/2" X 3 5/8" BUTT GLAZE MULLION 1/4" GLAZING	E-3416
 2 1/2" X 5 1/4" OPEN BACK HEAD/JAMB 1/4" GLAZING	E-3405	 2 1/2" X 5 1/4" BUTT GLAZE MULLION 1/4" GLAZING	E-3417
 2 1/2" X 3 5/8" OPEN BACK HEAD/JAMB 1" GLAZING	E-3406	 CLOSURE FOR 3 5/8" ROLL OVER HORIZONTAL	E-3418
 2 1/2" X 5 1/4" OPEN BACK HEAD/JAMB 1" GLAZING	E-3407	 CLOSURE FOR 5 1/4" ROLL OVER HORIZONTAL	E-3419
 2 1/2" X 3 5/8" ROLL OVER HORIZONTAL 1/4" GLAZING	E-3408	 3 5/8" GLAZING BEAD FOR INSIDE GLAZE HORIZONTALS 1" GLAZING	E-3420
 2 1/2" X 5 1/4" ROLL OVER HORIZONTAL 1/4" GLAZING	E-3409	 3 5/8" GLAZING BEAD FOR INSIDE GLAZE HORIZONTALS 1/4" SPANDREL GLAZING	E-3421
 2 1/2" X 3 5/8" ROLL OVER HORIZONTAL 1" GLAZING	E-3410	 5 1/4" GLAZING BEAD FOR INSIDE GLAZE HORIZONTALS 1" GLAZING	E-3422
 2 1/2" X 5 1/4" ROLL OVER HORIZONTAL 1" GLAZING	E-3411	 5 1/4" GLAZING BEAD FOR INSIDE GLAZE HORIZONTALS 1/4" SPANDREL GLAZING	E-3423













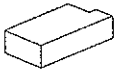
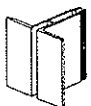



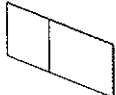

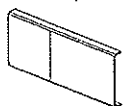
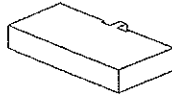
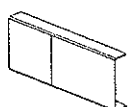
NOTE: 'M' INDICATES FACTORY INSTALLED ISOLATOR GASKET

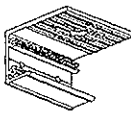
PARTS LIST - EXTRUSION

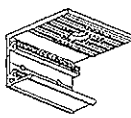

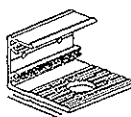

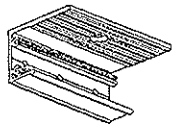

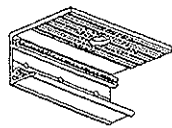



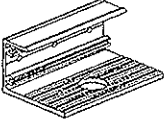

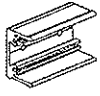

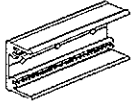

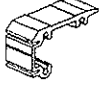

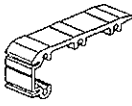
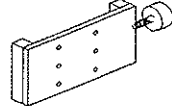
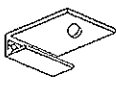
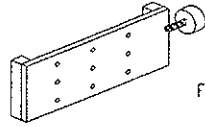
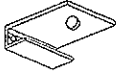

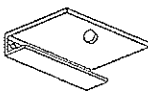
DESCRIPTION	PART NO.	DESCRIPTION	PART NO.
 SPANDREL GLAZING ADAPTOR 1' GLAZING	E-3424	 5 1/4" GLAZING BEAD FOR INSIDE GLAZE HORIZONTALS 1/4" GLAZING	E-3449
 BUTT GLAZE SPANDREL GLAZING ADAPTOR 1' GLAZING	E-3425	 135° BUTT GLAZE ADAPTOR	E-3488
 POCKET FILLER 1' GLAZING	E-3432	 135° PRESSURE PLATE 400 SERIES	M-3489
 3 5/8" INSIDE GLAZE HEAD HORIZONTAL 1/4" GLAZING	E-3435	 135° FACE CAP	E-3490
 5 1/4" INSIDE GLAZE HEAD HORIZONTAL 1/4" GLAZING	E-3436	 TYPICAL PRESSURE PLATE	M-3426
 3 5/8" INSIDE GLAZE HEAD HORIZONTAL 1' GLAZING	E-3437	 SHALLOW POCKET PERIMETER PRESSURE PLATE 1/4" GLAZING	M-3427
 5 1/4" INSIDE GLAZE HEAD HORIZONTAL 1' GLAZING	E-3438	 DEEP POCKET PERIMETER PRESSURE PLATE 1/4" GLAZING	M-3428
 90° D.S. CORNER EXTENSION FOR USE WITH E-3402	E-3443	 SHALLOW POCKET PERIMETER PRESSURE PLATE 1' GLAZING	M-3429
 90° D.S. CORNER EXTENSION FOR USE WITH E-3403	E-3444	 DEEP POCKET PERIMETER PRESSURE PLATE 1' GLAZING	M-3430
 90° D.S. CORNER ADAPTOR	E-3445	 POCKET FILLER 1/4" GLAZING	E-3431
 90° D.S. CORNER PRESSURE PLATE	E-3446	 2 1/2" X 1 1/2" SNAP COVER	E-4TB-05
		 2 1/2" X 1" SNAP COVER	E-4TB-33

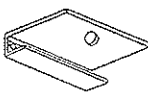
NOTE: 'M' INDICATES FACTORY INSTALLED ISOLATOR GASKET & PRE-PUNCHED AT 10" O.C.

PARTS LIST - ACCESSORIES

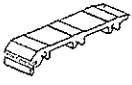
DESCRIPTION	PART NO.	DESCRIPTION	PART NO.
 2 1/2' X 3/4' SNAP COVER	E-4TB-64	 SILICONE COMPATIBLE DEEP POCKET HORIZONTAL END DAM FOR 1/4' GLAZING	P-2007
 2 1/2' X 5/8' SNAP COVER	E-4TB-77	 SILICONE COMPATIBLE SHALLOW POCKET HORIZONTAL END DAM	P-2008
 TEMPORARY GLAZING RETAINER FOR E-3416 & E-3417 BUTT GLAZE MULLIONS	P-1108	 SILICONE COMPATIBLE DEEP POCKET HORIZONTAL END DAM FOR 1' GLAZING	P-2009
 LOCKING LUG FOR USE WITH SILL SHEAR BLOCK / ANCHOR	P-1267	 4' LONG E.P.D.M. SETTING BLOCK FOR 1/4' GLAZING	P-2010
 ALUMINUM SPLICE FOR E-4TB-77 SNAP COVER	P-1628A	 4' LONG E.P.D.M. SETTING BLOCK FOR 1' GLAZING	P-2011
 FORMED ALUMINUM SPLICE FOR E-4TB-64 SNAP COVER	P-1628B	 SILICONE COMPATIBLE BUTT GLAZE HORIZONTAL END DAM FOR 1' GLAZING	P-2012
 FORMED ALUMINUM SPLICE FOR E-4TB-33 SNAP COVER	P-1628C	 SILICONE COMPATIBLE BUTT GLAZE HORIZONTAL END DAM FOR 1/4' GLAZING	P-2012
 SILICONE COMPATIBLE SPACER GASKET FOR 1' GLAZING	P-1690	 HEAD HORIZONTAL SHEAR BLOCK / ANCHOR FOR 3 5/8' MULLIONS WITH P-2028 PIPE SLEEVE	P-2015A
 E.P.D.M. EXTERIOR GLAZING GASKET	P-2002	 HEAD HORIZONTAL SHEAR BLOCK / ANCHOR FOR 3 5/8' MULLIONS WITH P-2029 PIPE SLEEVE	P-2015B
 E.P.D.M. INTERIOR GLAZING GASKET	P-2003	 SILL HORIZONTAL SHEAR BLOCK / ANCHOR FOR 3 5/8' MULLIONS WITH P-1267 LOCKING LUG	P-2015C
 E.P.D.M. INTERIOR WEDGE GLAZING GASKET	P-2005	 HEAD HORIZONTAL SHEAR BLOCK / ANCHOR FOR 5 1/4' MULLIONS WITH P-2028 PIPE SLEEVE	P-2016A
 SILICONE COMPATIBLE SHALLOW POCKET HORIZONTAL END DAM FOR 1/4' GLAZING	P-2006	 HEAD HORIZONTAL SHEAR BLOCK / ANCHOR FOR 5 1/4' MULLIONS WITH P-2029 PIPE SLEEVE	P-2016B

PARTS LIST - ACCESSORIES

DESCRIPTION	PART NO.	DESCRIPTION	PART NO.
 SILL HORIZONTAL SHEAR BLOCK / ANCHOR FOR 5 1/4" MULLIONS WITH P-1267 LOCKING LUG	P-2016C	 10' LONG MULLION SPLICE FOR 5 1/4" MULLIONS (2) PER SPLICE	P-2026
 INTERMEDIATE HORIZONTAL SHEAR BLOCK FOR 3 5/8" MULLIONS	P-2017	 MULLION END CAP	P-2027
 INTERMEDIATE HORIZONTAL SHEAR BLOCK FOR 5 1/4" MULLIONS	P-2018	 7/16" I.D. X 1' LONG PIPE SLEEVE SPACER FOR 3/8" ATTACHMENTS	P-2028
 INTERMEDIATE HORIZONTAL SHEAR BLOCK FOR 3 5/8" ROLL OVER HORIZONTAL	P-2019	 9/16" I.D. X 1' LONG PIPE SLEEVE SPACER FOR 1/2" ATTACHMENTS	P-2029
 INTERMEDIATE HORIZONTAL SHEAR BLOCK FOR 5 1/4" ROLL OVER HORIZONTAL	P-2020	 DRILL FIXTURE FOR SHEAR BLOCKS FOR 3 5/8" HORIZONTALS	P-2043
 SHEAR BLOCK / ANCHOR FOR 3 5/8" INSIDE GLAZE HEAD HORIZONTAL WITH P-2028 PIPE SLEEVE	P-2021A	 DRILL FIXTURE FOR SHEAR BLOCKS FOR 5 1/4" HORIZONTALS	P-2044
 SHEAR BLOCK / ANCHOR FOR 3 5/8" INSIDE GLAZE HEAD HORIZONTAL WITH P-2029 PIPE SLEEVE	P-2021B	 1/4-20 X 1' HEX HEAD ZINC PLATED SCREW FOR ATTACHMENT OF PRESSURE BARS	S-203
 SHEAR BLOCK / ANCHOR FOR 5 1/4" INSIDE GLAZE HEAD HORIZONTAL WITH P-2028 PIPE SLEEVE	P-2022A	 #12-24 X 1' HEX HEAD ZINC PLATED SCREW FOR ATTACHMENT OF SHEAR BLOCKS	S-204
 SHEAR BLOCK / ANCHOR FOR 5 1/4" INSIDE GLAZE HEAD HORIZONTAL WITH P-2029 PIPE SLEEVE	P-2022B	 #12-24 X 2' HEX HEAD ZINC PLATED SCREW FOR ATTACHMENT OF SHEAR BLOCKS	S-205
 SHEAR BLOCK FOR 3 5/8" INSIDE GLAZE, ROLL OVER INTERMEDIATE HORIZONTAL	P-2023	 #10-24 X 1 1/2" PPH ZINC PLATED SCREW FOR CONCEALED ATTACHMENT OF HORIZONTALS	S-206
 SHEAR BLOCK FOR 5 1/4" INSIDE GLAZE, ROLL OVER INTERMEDIATE HORIZONTAL	P-2024	 #10-24 X 1 1/4" PFH ZINC PLATED SCREW FOR ATTACHMENT OF E-3425 BUTT GLAZE ADAPTOR	S-207
 10' LONG MULLION SPLICE FOR 3 5/8" MULLIONS (2) PER SPLICE	P-2025	 #10-24 X 3/4" PPH ZINC PLATED SCREW FOR CONCEALED ATTACHMENT OF HORIZONTALS	S-270

# GENERAL CONSTRUCTION NOTES

1. These instructions cover typical product application, fabrication, installation and standard conditions and are general in nature. These should be used as a guideline and in conjunction with approved shop drawings. The shop drawings take precedence and may include additional details specific to this project. Any conflict or discrepancies must be clarified through Tubelite's Engineering Department prior to execution. See shop drawings for entrance requirements, steel reinforcing and special project situations.
2. Materials stored at the job site must be kept in a safe place removed from possible damage by other trades. Stack with adequate separation so that materials do not rub together. Store off the ground. Cardboard or paper wrapped materials must be kept dry. Check arriving materials for quantity and keep record of where various materials are stored.
3. All field welding of steel anchor clips must be done in accordance with AISC guidelines. All welds should be touched up with a rust resistant primer. All aluminum and glass should be shielded from field welding to avoid damage from weld splatter. Results will be unsightly and may be structurally unsound. Advise general contractor and other trades accordingly.
4. Coordinate protection of installed work with general contractor and/or other trades.
5. Coordinate sequence of other trades which affect framing installation with the general contractor (e.g. fire proofing, back up walls, partitions, ceiling, mechanical ducts etc.)
6. General contractor should furnish and guarantee bench marks, offset lines and opening dimensions. These items should be checked for accuracy before proceeding with erection. Make certain that all adjacent substrate construction is in accordance with the contract documents and/or approved shop drawings. If not, notify the general contractor in writing before proceeding with installation because this could constitute acceptance of adjacent substrate construction by others.
7. Isolate all aluminum to be placed directly in contact with masonry or other incompatible materials with a heavy coat of zinc chromate or bituminous paint.
8. Sealant selection is the responsibility and option of the erector, installer and/or glazing contractor and must be approved by the sealant manufacturer with regard to application and compatibility for its intended use. All sealants must be used in strict accordance with the manufacturer's instructions and applied only by trained personnel to surfaces that have been properly prepared.
9. Sealants must be compatible with all materials with which they have contact, including other sealant surfaces. Consult sealant manufacturer for recommendations relative to shelf life, compatibility, cleaning of substrate, priming, tooling, adhesion, etc.
10. Drainage gutters and weep holes must be kept clean at all times. Tubelite cannot accept responsibility for improper drainage as a result of clogged gutters and weep holes.
11. This product requires clearances at head, sill and jambs to allow for thermal expansion and contraction. A 3/8" minimum joint is recommended. Joints smaller than 3/8" may be subject to failure. Consult your sealant supplier.
12. All materials to be installed plumb, level and true with regard to established bench marks and column center lines established by the general contractor and checked by the erector, installer and/or glazing contractor.
13. Cleaning of exposed aluminum surfaces should be done with AAMA recommendations.

## 400 I.G. SERIES CURTAIN WALL

Tubelite 400 I.G. Series Curtain Wall has been designed for low and medium rise applications. It was designed to provide either four-sided conventional captured support or two-sided horizontal captured support combined with two-sided vertical structural silicone support.

Offset glazing pockets and removable interior stops allow glazing or re-glazing from both the exterior and interior of the building. Broken lites can be replaced from the exterior of the building without removal of the vertical face caps or pressure plates. Glazing can also be alternately inside and/or outside glazed if the application so requires.

The rollover horizontal members permit erection of the verticals first, to reduce installation time and costs. Open back head and jamb members provide economical alternatives to tubular members.

In structural glazed applications the integrity of the wall depends greatly on the quality of the installation. Clean materials, primed if necessary, carefully filled and tooled sealant pockets (no voids) and adequate curing time are extremely critical factors.

It is the responsibility of the Glazing Contractor to submit samples of framing members to the silicone manufacturer for adhesion testing. Samples of the glazing accessories, that will come in contact with the silicone, should also be submitted for compatibility testing. Incompatible materials may result in unsightly discoloration which could result in loss of adhesion and structural failure.

Silicone will be applied in two steps. After the installation of the silicone compatible spacer gasket (P-1690) and placement of temporary glazing retainer clips, the structural silicone joint is installed from the interior. After curing, the temporary glazing retainer clips (P-1108) are removed and the silicone weather seal is installed from the exterior.

Installers should follow these instructions for the fabrication, assembly and installation of this system and the silicone manufacturer's instructions and recommendations for the application of the silicone.

### GLASS SIZES

Glass Height: Daylight Opening + 1" (See Fig. 2)

Glass Width: Daylight Opening + (See Fig. 1)

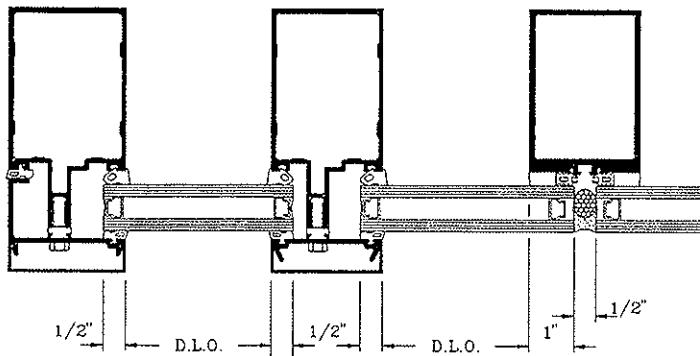

FIGURE 1

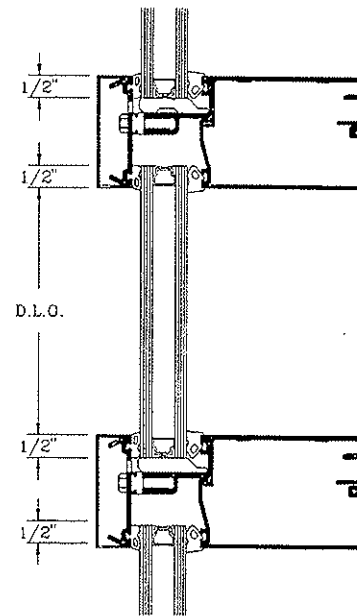

FIGURE 2

Note: These formulas do not take into account out of square openings or glass manufacturing tolerances. Consult your glass manufacturer before ordering glass.

## FRAME FABRICATION

Tubelite 400 I.G. Series Curtain Wall has been designed for mullions, pressure plates and snap covers, to run through and be cut the same dimension as the frame height shown on the approved shop drawings. (see figure 4) Horizontal framing members run between the vertical members and are cut slightly shorter than the daylight opening dimension to allow for thermal expansion and contraction. (see figure 3)

### CUTTING

Cut mullions, pressure plates and snap covers to the frame height. See figure 4

Cut horizontal D.L.O.  $-1/16''$   
See figure 3.

Cut horizontal pressure plates D.L.O.  $-1/4''$   
See figure 3.

Cut horizontal snap covers D.L.O.  $-1/16''$   
See figure 3.

Cut horizontal glazing adaptors D.L.O.  $-1/16''$   
See figure 3.

Cut interior horizontal glass stops  
D.L.O.  $-3/32''$

Cut vertical glazing adaptors D.L.O.  $+1\ 1/4''$   
See figure 4.

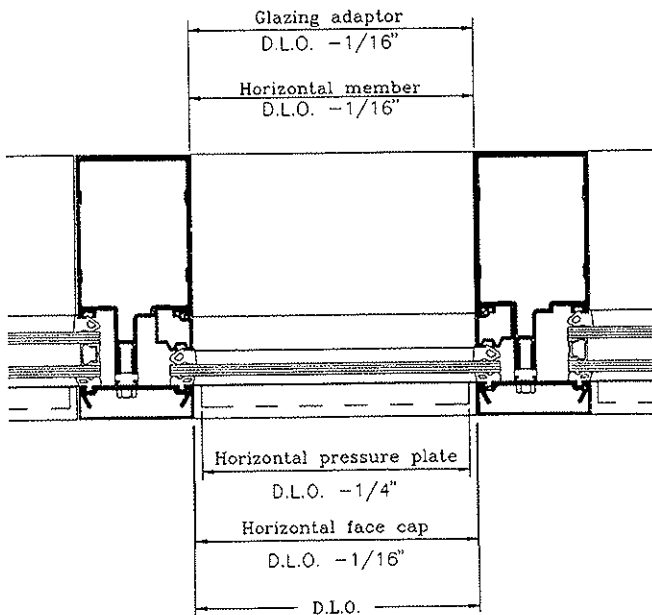

FIGURE 3

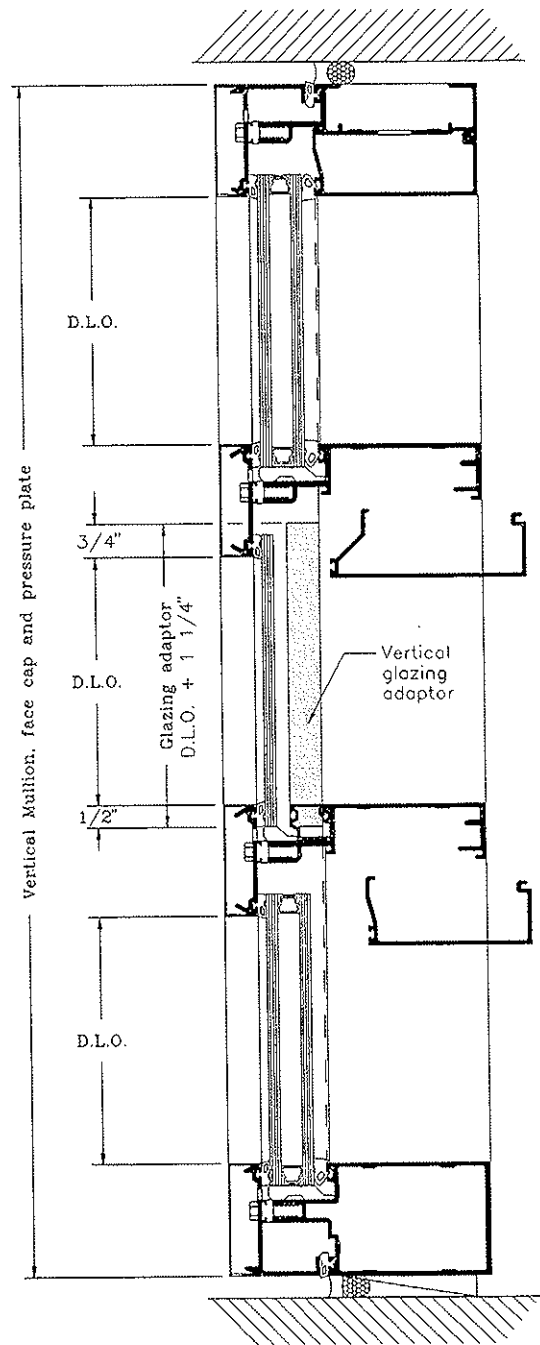

FIGURE 4



# FRAME FABRICATION / VERTICAL

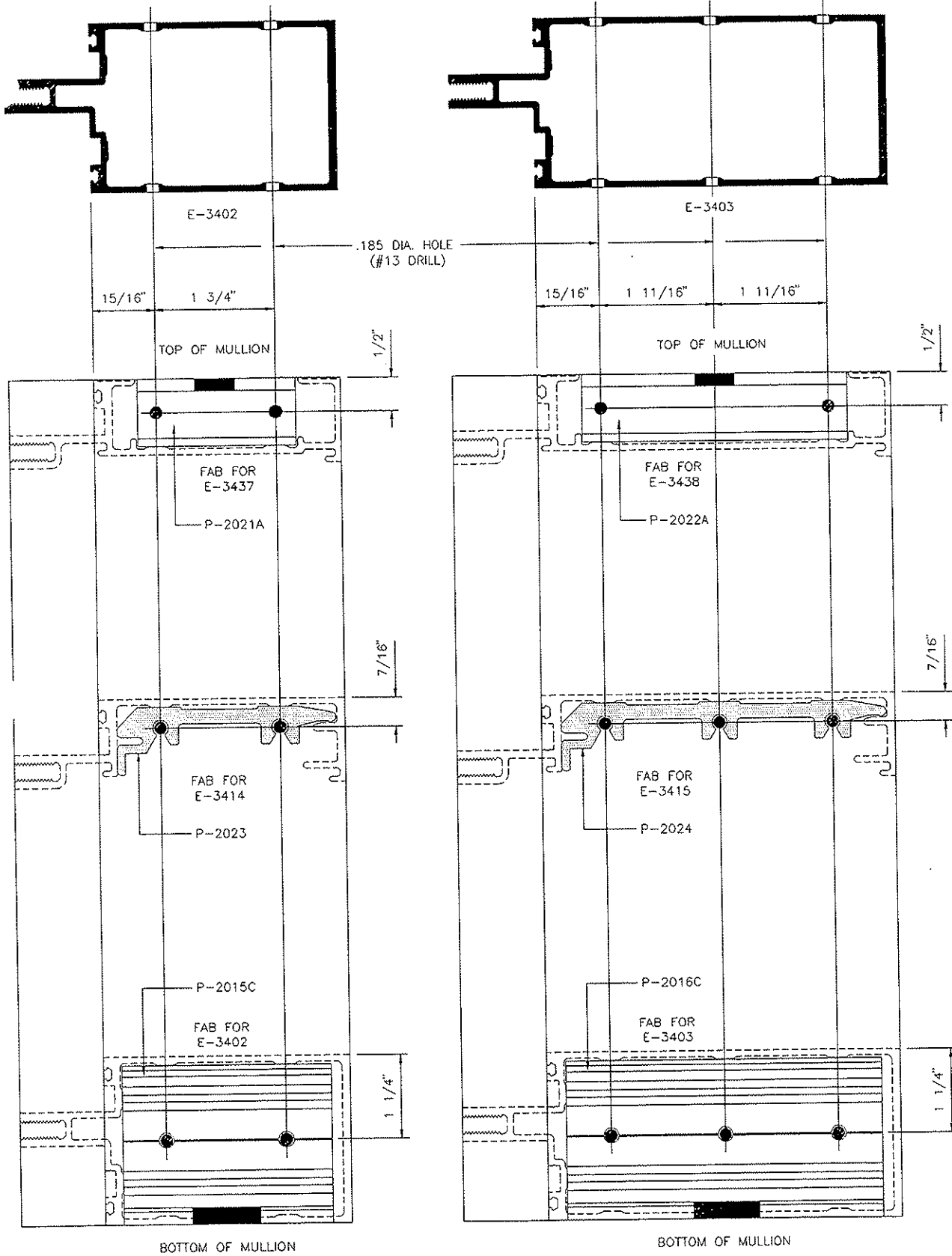

FIGURE 7

FIGURE 8

# FRAME FABRICATION / VERTICAL

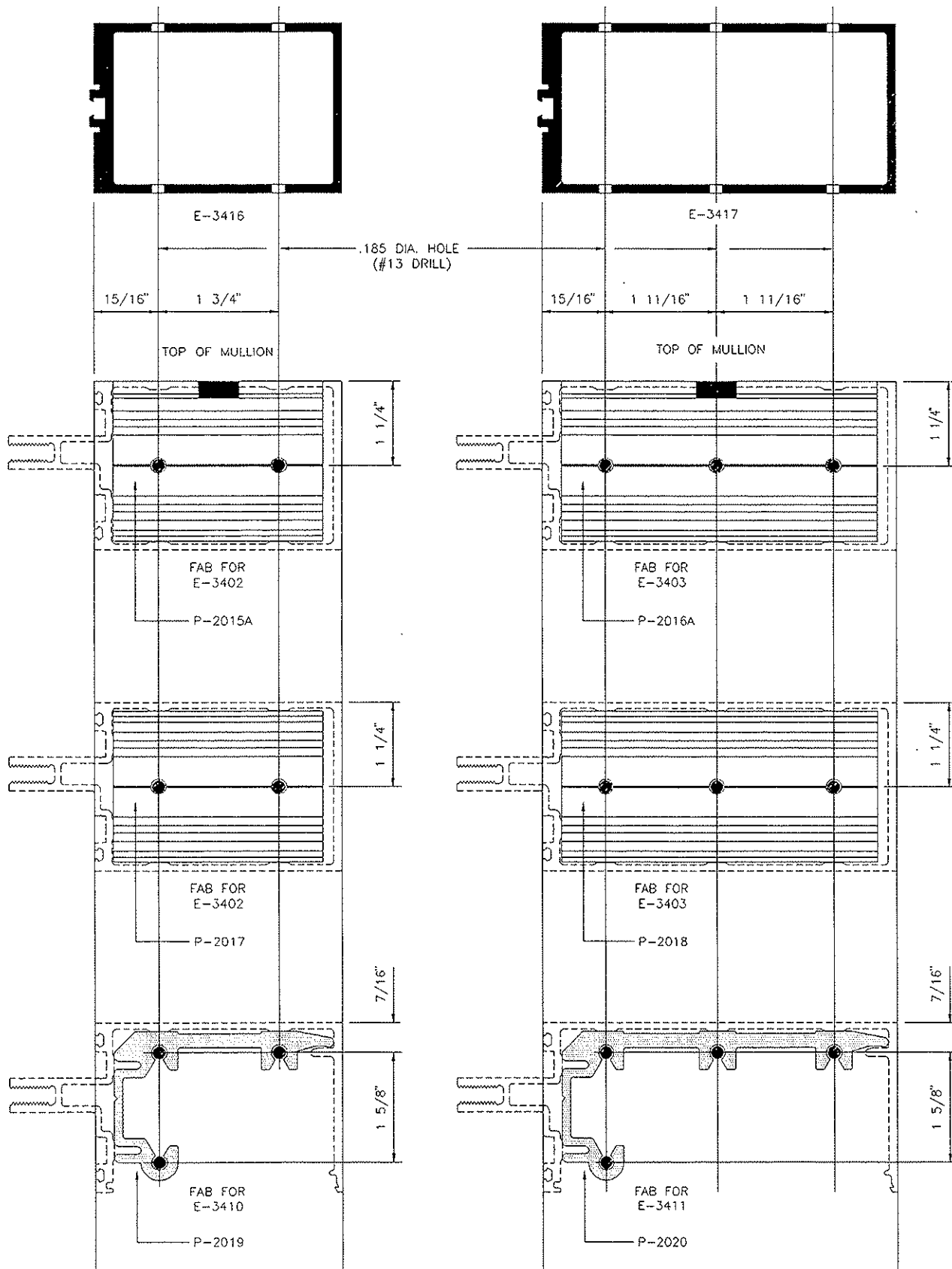

FIGURE 9

FIGURE 10

# FRAME FABRICATION / VERTICAL

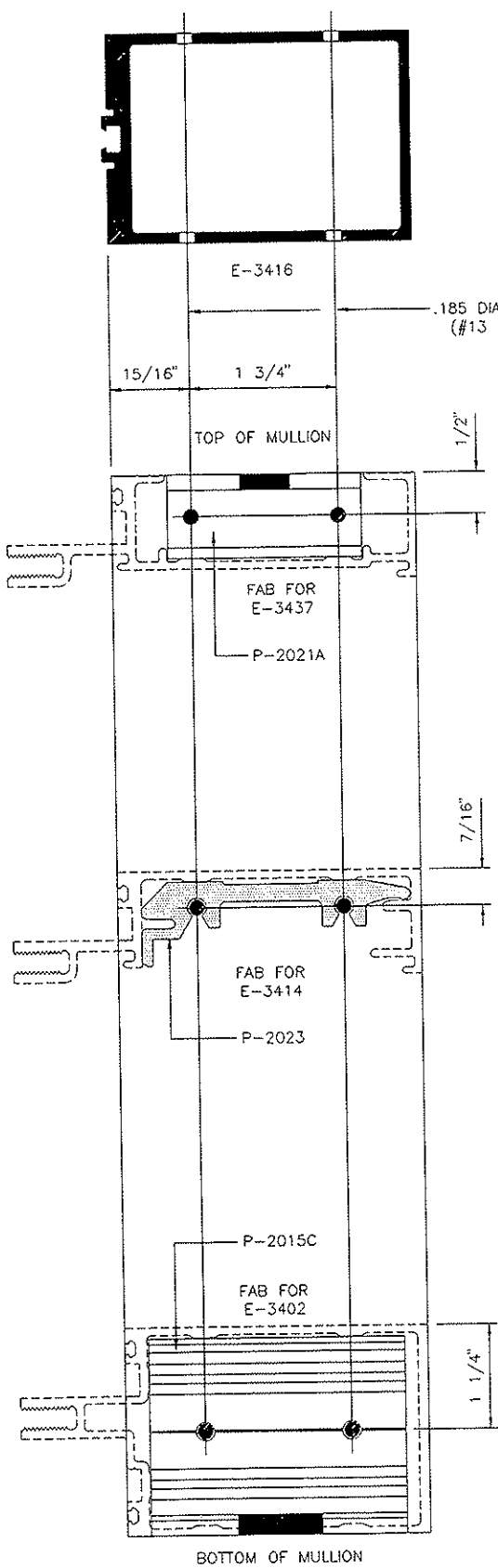

FIGURE 11

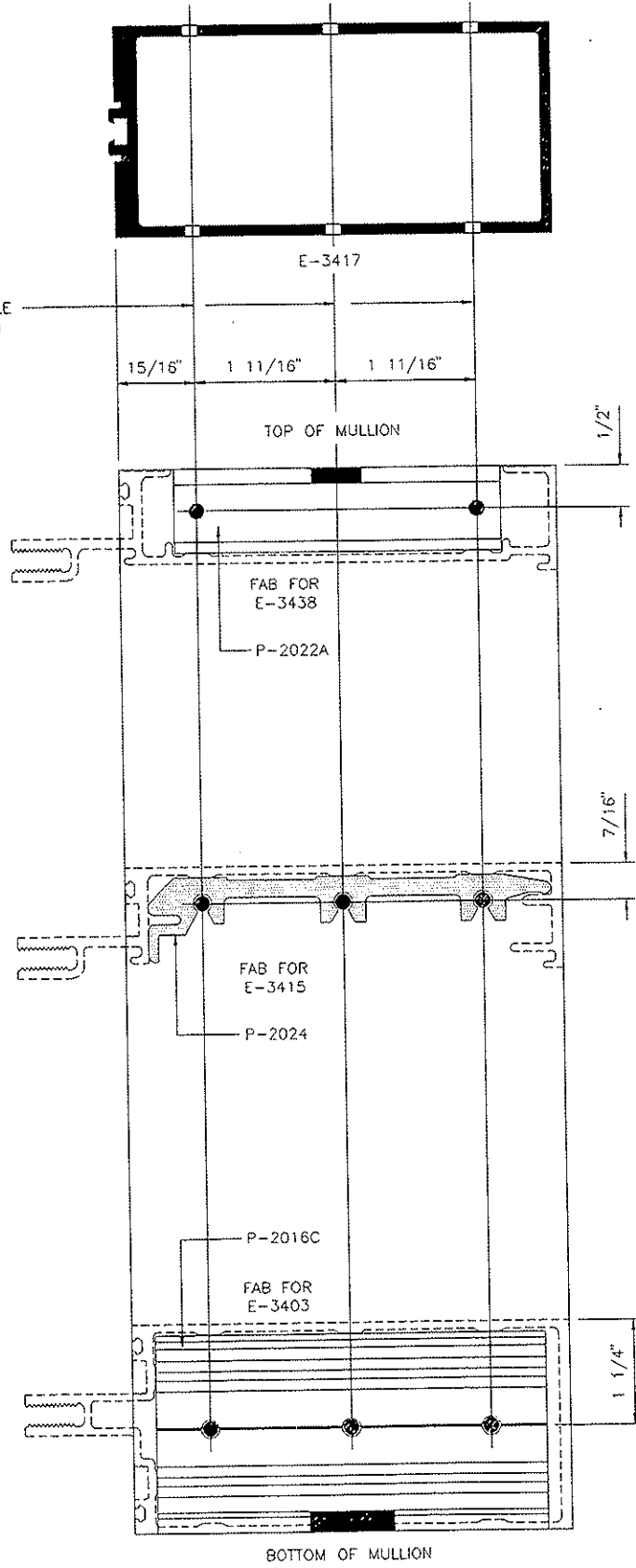

FIGURE 12

# FRAME FABRICATION / HORIZONTAL

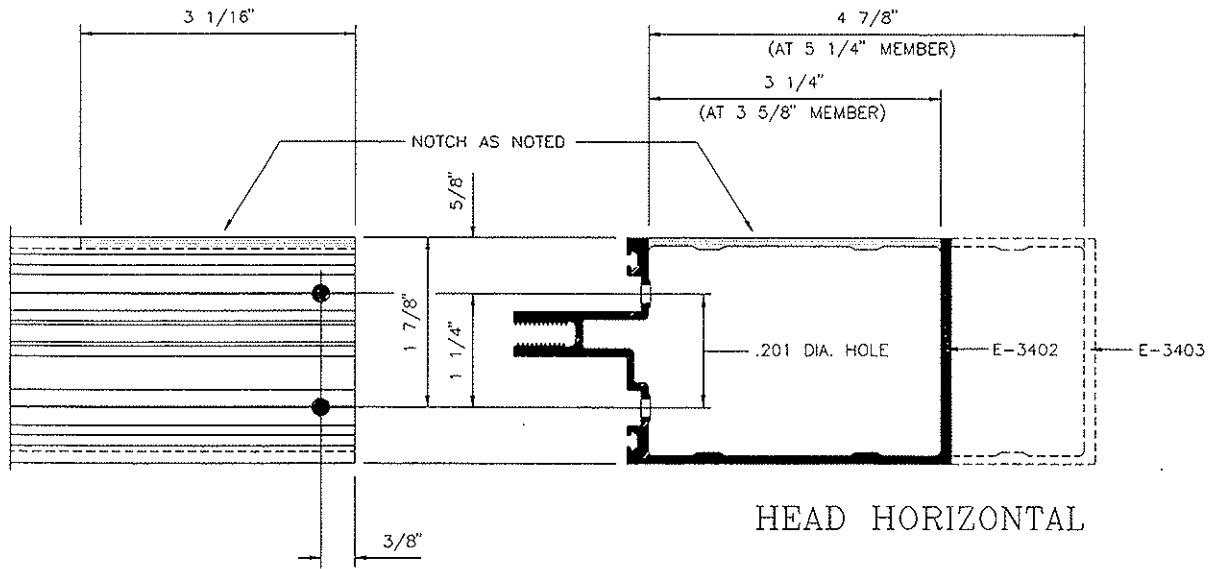

FIGURE 13

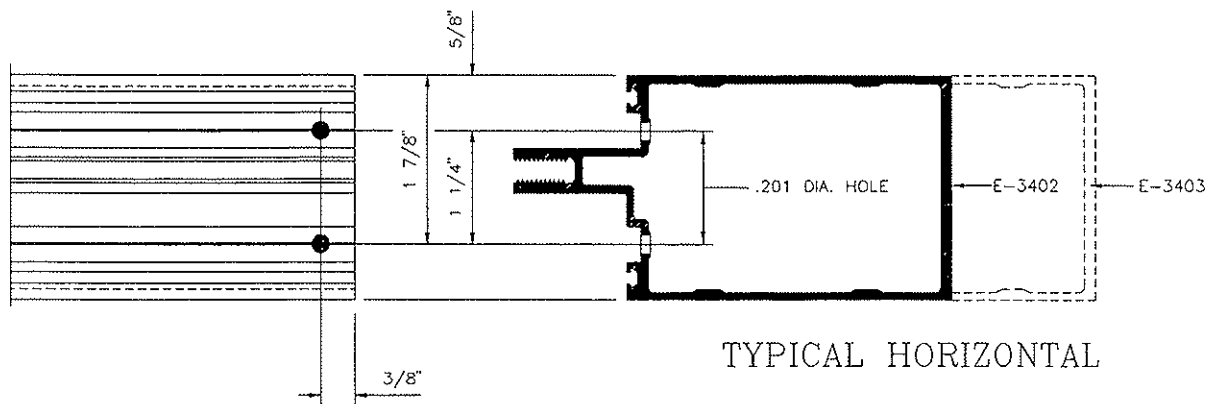

FIGURE 14

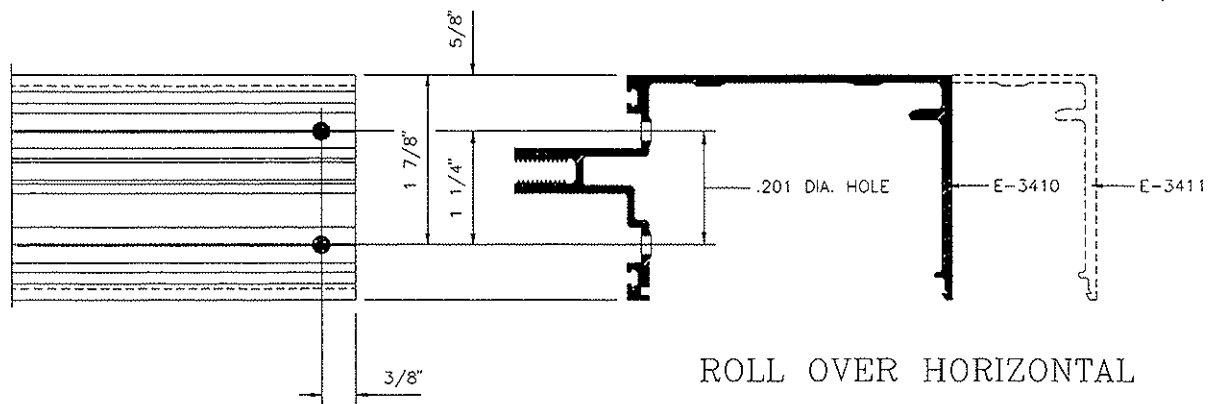
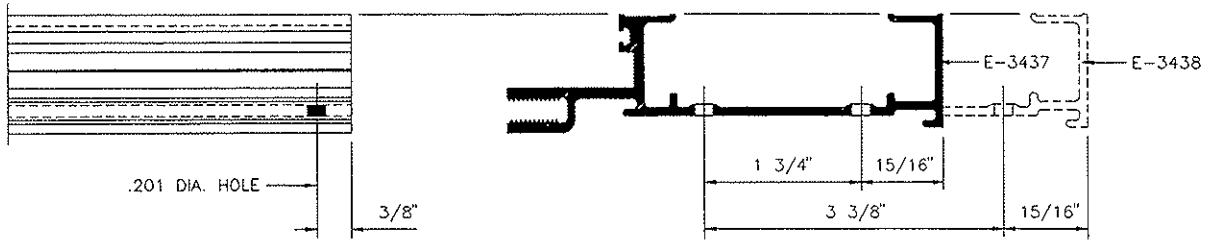

FIGURE 15

FRAME FABRICATION / HORIZONTAL



INSIDE GLAZE  
HEAD HORIZONTAL

FIGURE 16

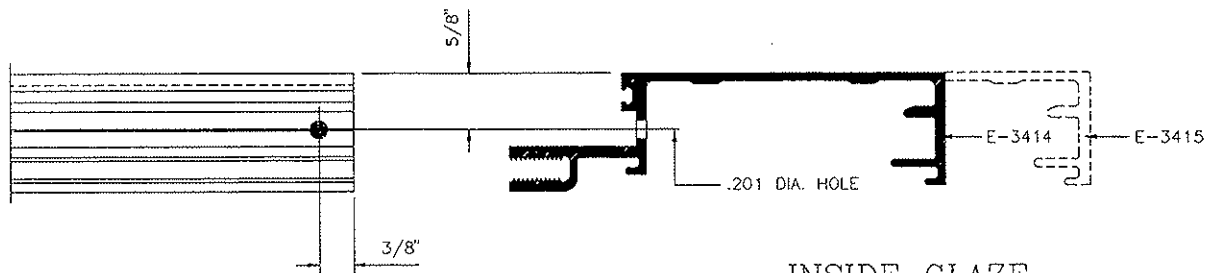

INSIDE GLAZE  
TYPICAL HORIZONTAL

FIGURE 17

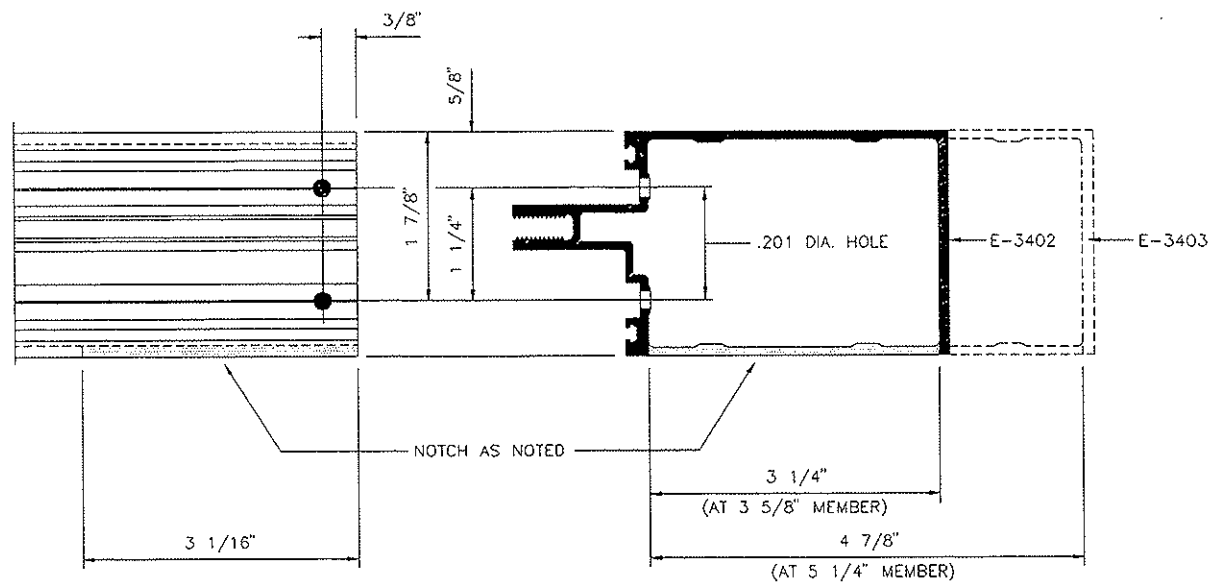

SILL HORIZONTAL

FIGURE 18

# FRAME FABRICATION

## VERTICAL PRESSURE PLATES

Cut vertical pressure plate same length as mullion.

Pressure plate comes factory punched on 10" centers. Maximum distance from either end to first hole is 1 1/2". Drill additional holes if necessary.

## HORIZONTAL PRESSURE PLATES

Cut horizontal pressure plate daylight opening (D.L.O.) -1/4".

Pressure plate comes factory punched on 10" centers. Maximum distance from either end to first hole is 1 1/2". Drill additional holes if necessary.

Drill 1/4" diameter weep holes at approximately 1/4 points but no closer than 4" from either end. See figures 19, 20 & 21.

## VERTICAL SNAP COVERS

Cut vertical snap cover same length as mullion and vertical pressure plate.

## HORIZONTAL SNAP COVERS

Cut horizontal snap covers daylight opening (D.L.O.) -1/16". Make 1/4" x 1/2" weep slot in bottom edge of snap cover, adjacent to each vertical member. See figure 35.

## VERTICAL GLAZING ADAPTORS

Cut vertical spandrel glazing adaptors daylight opening (D.L.O.) height + 1 1/4". See figure 4.

## HORIZONTAL GLAZING ADAPTORS

Cut horizontal spandrel glazing adaptors daylight opening (D.L.O.) width -1/16". See figure 3.

Notch horizontal spandrel adaptors at each end as noted to clear shear block attachment screw heads. See figure 22.

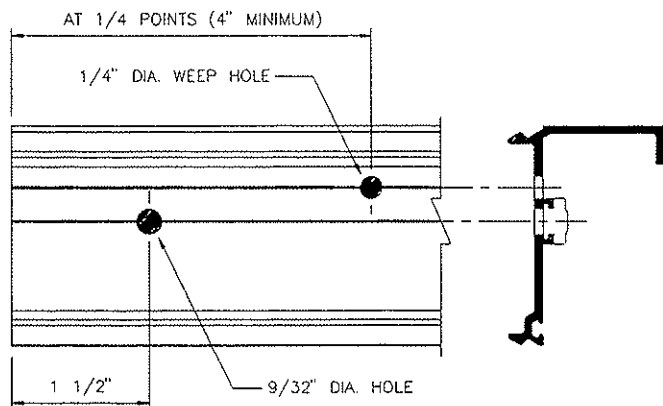

FIGURE 19

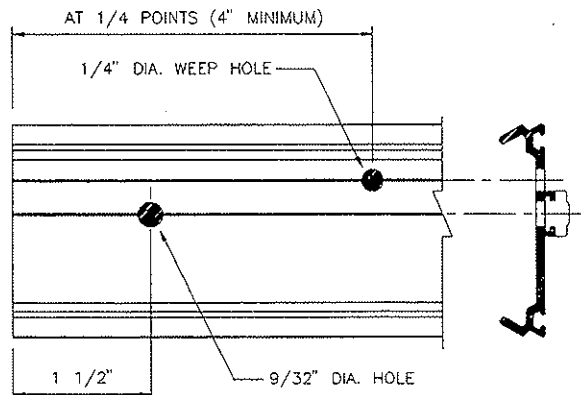

FIGURE 20

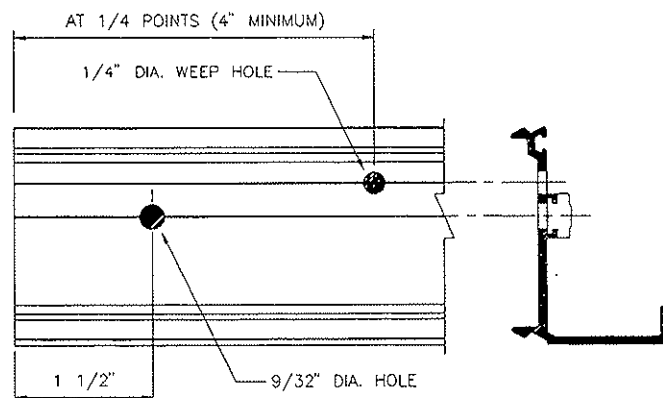

FIGURE 21

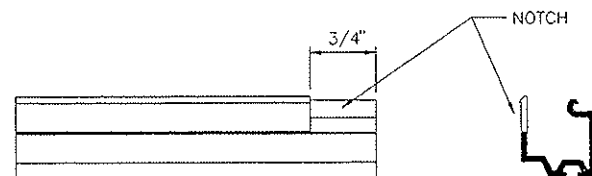

FIGURE 22

# FRAME ASSEMBLY - MULLIONS & HORIZONTALS

1. Layout and fabricate mullions for shear blocks per figures 5 thru 12.
2. Layout and fabricate horizontals for attachment to shear blocks per figures 13 thru 18.
3. Attach shear blocks to mullions with #12 fastener indicated.

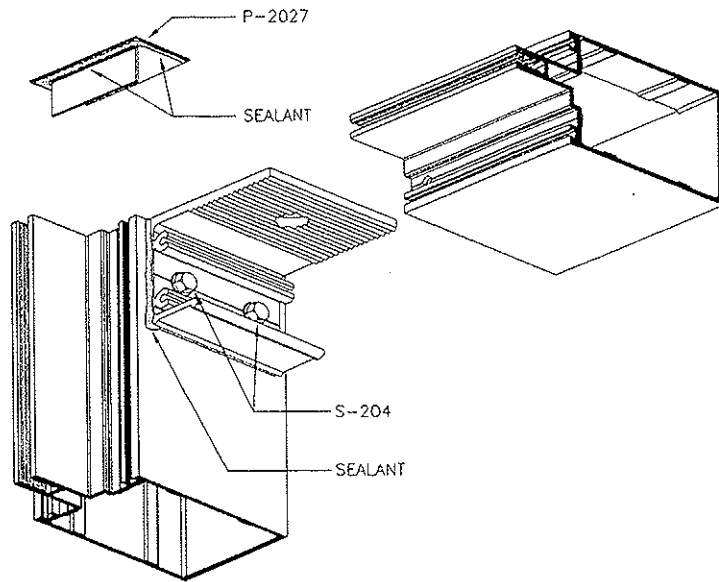
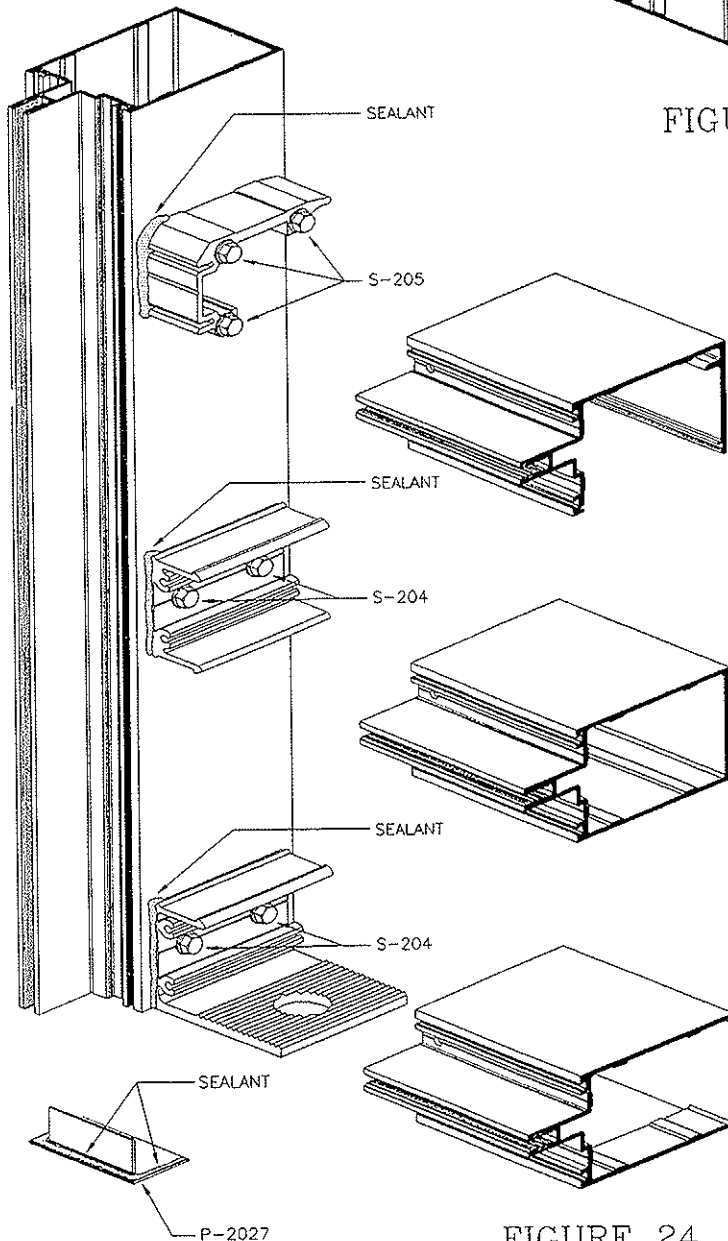

FIGURE 23



4. Apply sealant to P-2027 end dam as shown and install in ends of mullions. These can either be installed with silicone sealant as shown or attached to ends of mullions with S-206 screws. See figure 23 and 24.
5. If mullion splices are required they would also be applied at this time. See figures 27 and 28.
6. After installation of mullions in openings apply a bead of sealant to the front edge of each shear block as shown and install appropriate horizontals.
7. Attach horizontal to shear block with (1) or (2) S-270 or S-206 screws as required.
8. Cap seal heads of all screws used in glazing pockets.
9. Turn to figures 31 thru 34 for installation of end dams.

FIGURE 24

# ALTERNATE FRAME ASSEMBLY - INSIDE GLAZED MULLIONS & HORIZONTALS

1. Layout and fabricate mullions for shear blocks per figures 5 thru 12.
2. Layout and fabricate horizontals for attachment to shear blocks per figures 13 thru 18.
3. Attach shear blocks to mullions with #12 fastener indicated.

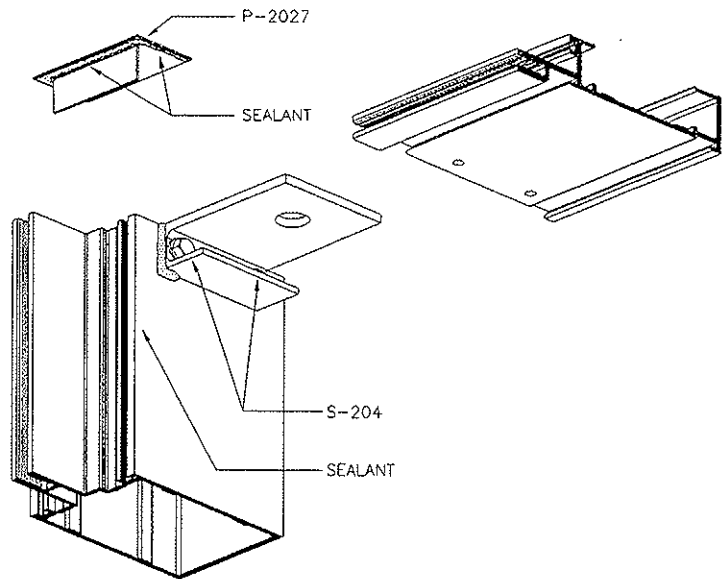
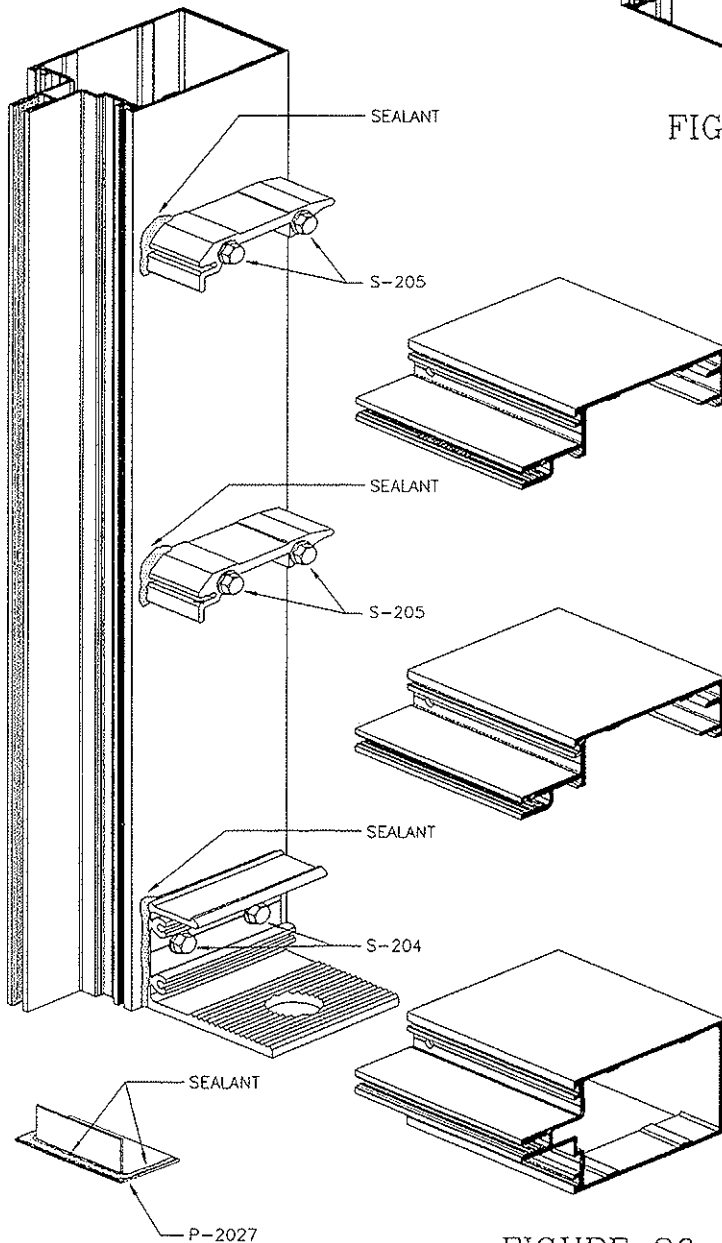

FIGURE 25



4. Apply sealant to P-2027 end dam as shown and install in ends of mullions. These can either be installed with silicone sealant as shown or attached to ends of mullions with S-206 screws. See figures 25 and 26.
5. If mullion splices are required they would also be applied at this time. See figures 27 and 28.
6. After installation of mullions in openings apply a bead of sealant to the front edge of each shear block as shown and install appropriate horizontals.
7. Attach horizontal to shear block with (1) or (2) S-270 or S-206 screws as required.
8. Cap seal heads of all screws used in glazing pockets. See figure 34.
9. Turn to figures 31 thru 34 for installation of end dams.

FIGURE 26

## FRAME ASSEMBLY - MULLION SPLICES (USE IF APPLICABLE)

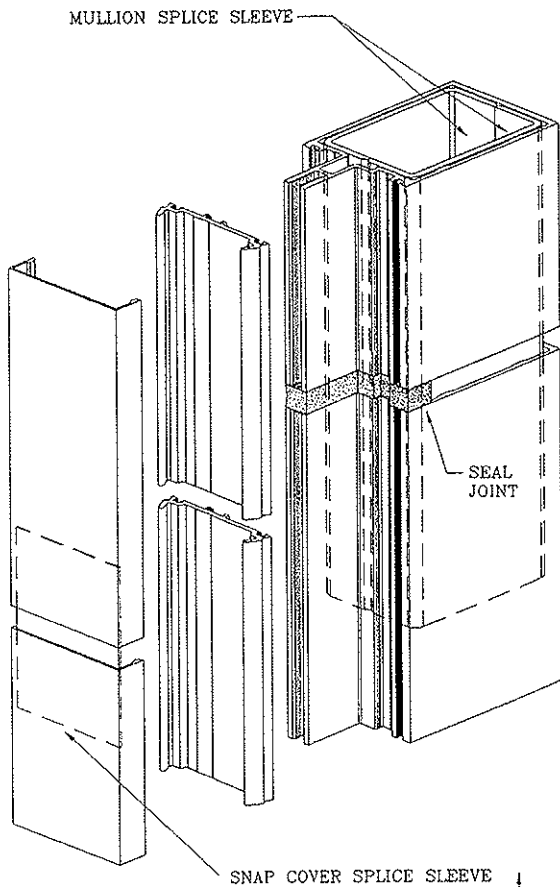

1. A 1/2" joint is recommended. Use (2) 1/4" horseshoe shims to set proper mullion joint. Once mullions are set and anchored, shims should be removed.
2. Splice joint should occur in spandrel areas.
3. Shop attach splice sleeves to lower mullion with (2) S-206 screws each.
4. Apply bond breaker tape to the front face of the splice sleeves where sealant is to be applied. See figure 27.
5. Clean projected portion of splice sleeves before assembly with upper mullion.
6. Seal between lower and upper mullion and tool joint. See figures 27 & 28
7. If 1/4" glazing adaptors are required they would be spliced and sealed at the same location as the mullion.

FIGURE 27

8. Stagger splice joints in mullions, pressure plates and snap covers. See figure 28.
9. Make sure that a pressure plate attachment fastener, S-203, is located no further than 1 3/4" from each end of pressure plates at splice joint. Seal joint between ends of pressure plates.
10. Install snap cover sleeve as required. See accessory parts list for proper snap cover sleeves.

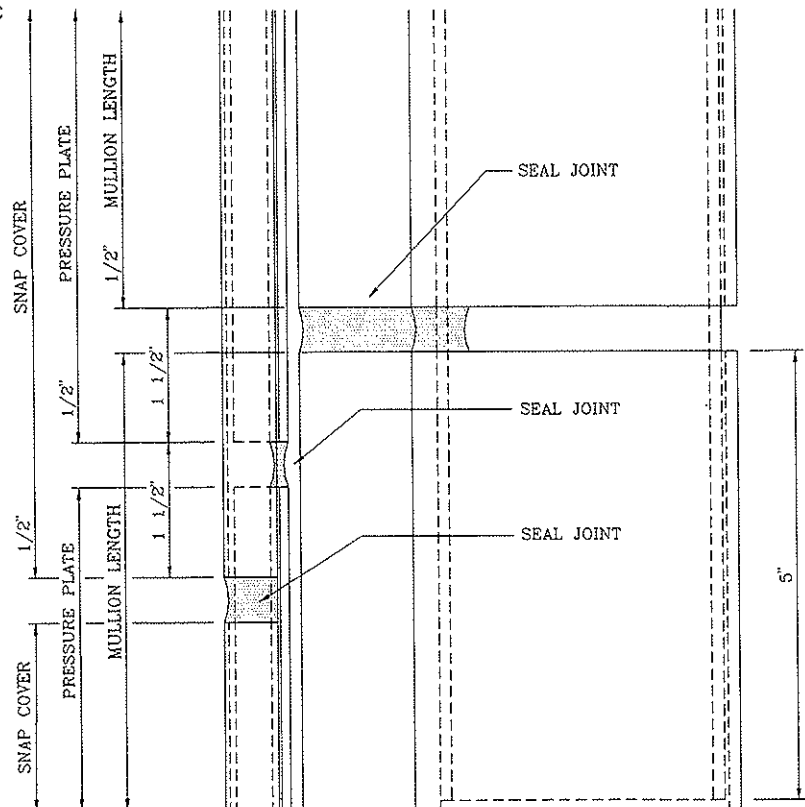

FIGURE 28

## FRAME ASSEMBLY - WINDLOAD/DEADLOAD ANCHORS (USE IF APPLICABLE)

Steel anchor clips for anchorage to structure are normally set before mullions are erected. These are typically line set and field drilled from control lines provided by the General Contractor. Be sure outstanding leg is 90° to the offset line.

Final anchors sizes, configuration, size of bolts, arrangement and quantity of fasteners may vary per job conditions from what is shown. Please refer to approved shop drawings or contact Tubelite engineering for exact requirements or recommendations.

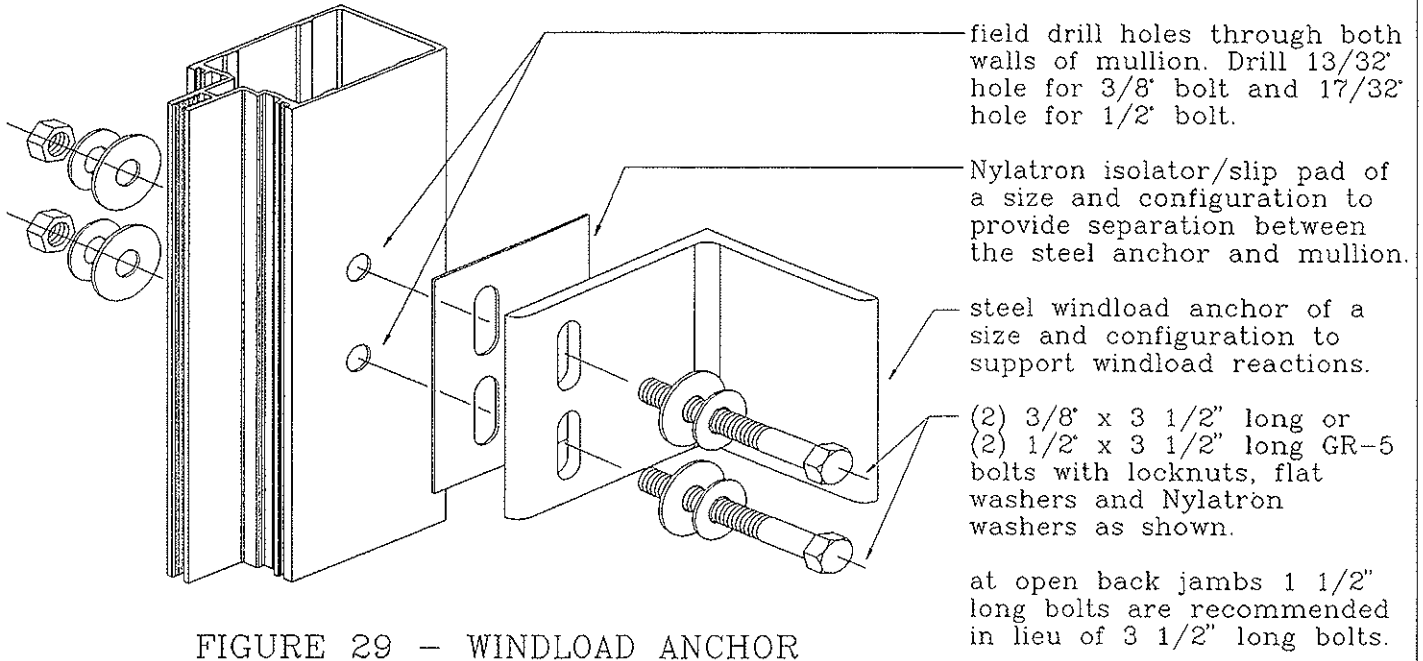

FIGURE 29 - WINDLOAD ANCHOR

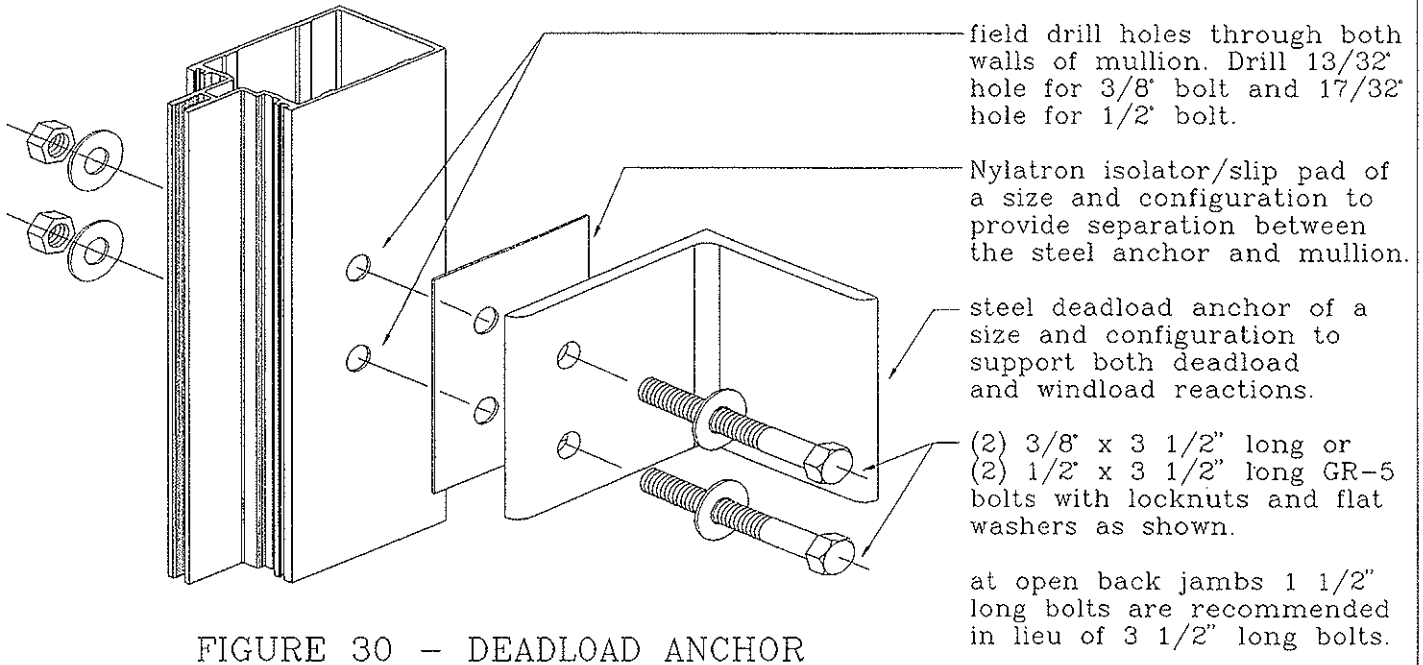

FIGURE 30 - DEADLOAD ANCHOR

Contact Tubelite Engineering for additional information on anchorage of this system.

## FRAME ASSEMBLY - END DAMS

### INSTALLATION OF END DAMS

1. Make sure all surfaces are clean and free of construction debris.
2. Apply sealant to the (3) initial contact surfaces and slide end dam into place.
3. Apply additional sealant in gasket reglet if necessary to provide water tight seal and tool.
4. Prior to installation of pressure plate apply sealant to remaining contact surface of end dam.
5. See Figures 31 thru 34.

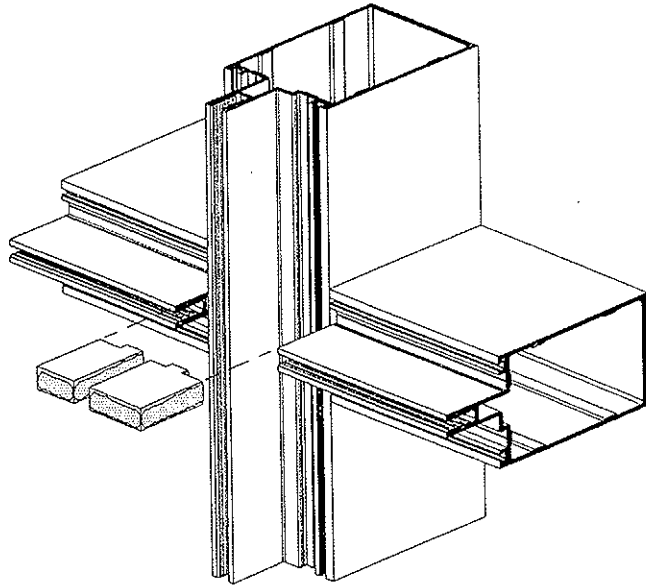

FIGURE 31

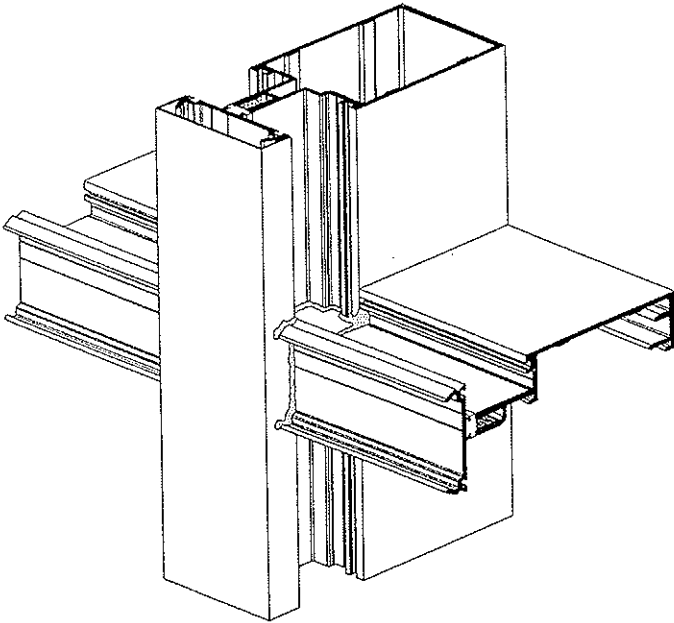

FIGURE 32

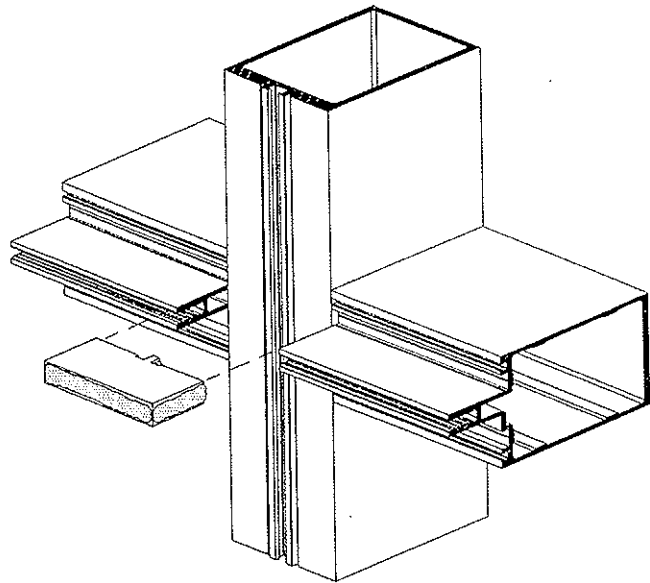

FIGURE 33

## FRAME ASSEMBLY - GASKETS

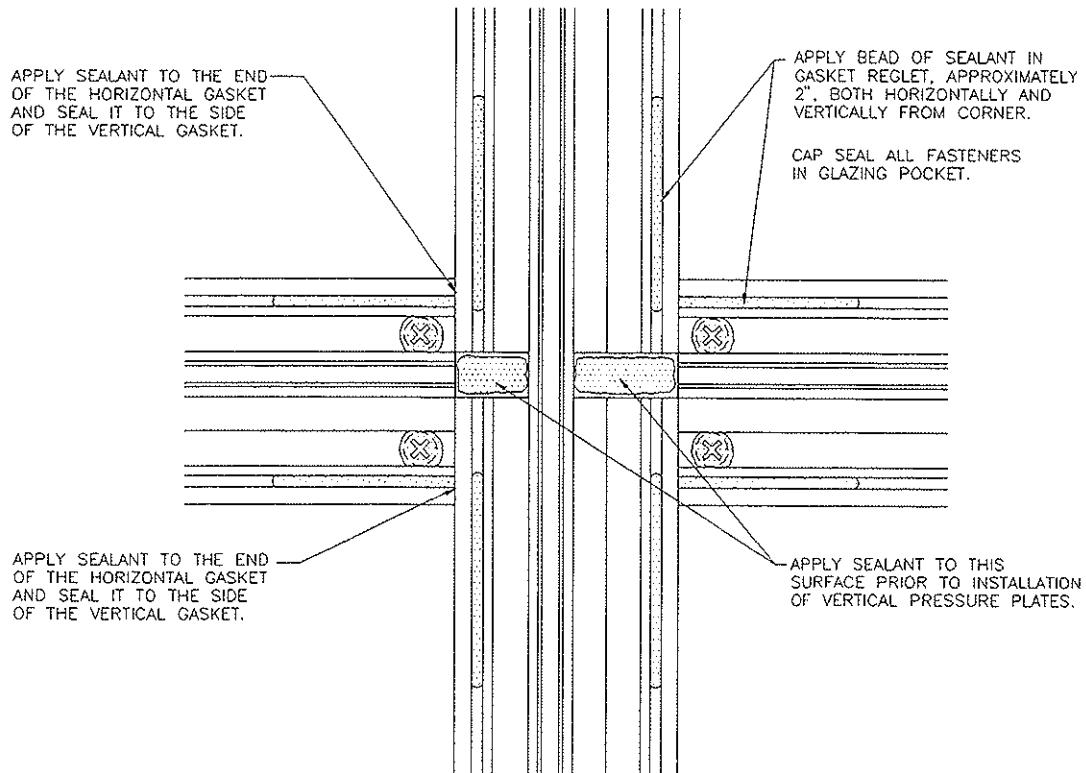

FIGURE 34

### INSTALLATION OF GASKETS

1. Make sure all surfaces are clean and free of construction debris.
2. Cut interior and exterior gaskets to size, allowing 1/8" of extra length per foot of D.L.O. for shrinkage.
3. Apply a bead of sealant in gasket reglet, approximately 2", both horizontally and vertically from corner.  
See figure 34
4. Vertical gaskets run thru and horizontal gaskets are sealed to side of the vertical gaskets at the corners.  
See figure 34

## FRAME ASSEMBLY - PRESSURE PLATES & SNAP COVERS

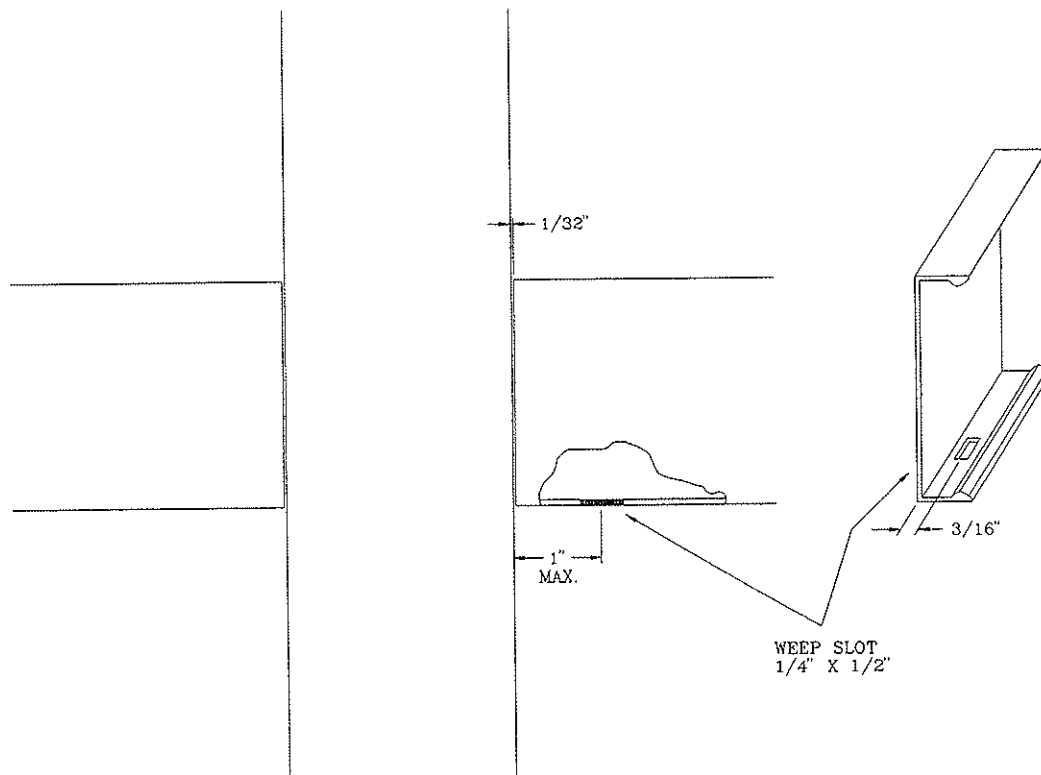

FIGURE 35

### PRESSURE PLATES AND SNAP COVERS

1. Install vertical pressure plates with S-203 screws at 10" on center.
2. Install vertical snap cover.  
Note: Care must be taken to prevent damage to snap cover during installation. Use a wood block and a mallet to snap on cover.
3. Install horizontal pressure plates with S-203 screws at 10" on center.  
Note: Pressure plates come factory punched on 10" centers. Maximum recommended distance for any end to the first hole should not exceed  $1\ 1/2''$ . Drill additional holes if necessary. See figures 19, 20, & 21.
4. Seal horizontal pressure plates to vertical snap cover. See figure 32.
5. For inside glaze applications apply additional sealant in horizontal gutter at vertical after installation of horizontal pressure plate if necessary to provide a water tight seal.
6. Install horizontal snap covers. Horizontal snap covers require  $1/4''$  x  $1/2''$  weep slot in bottom edge as shown in figure 35.

TYPICAL HORIZONTAL DETAILS / OUTSIDE GLAZED

TYPICAL OUTSIDE  
GLAZE HEAD

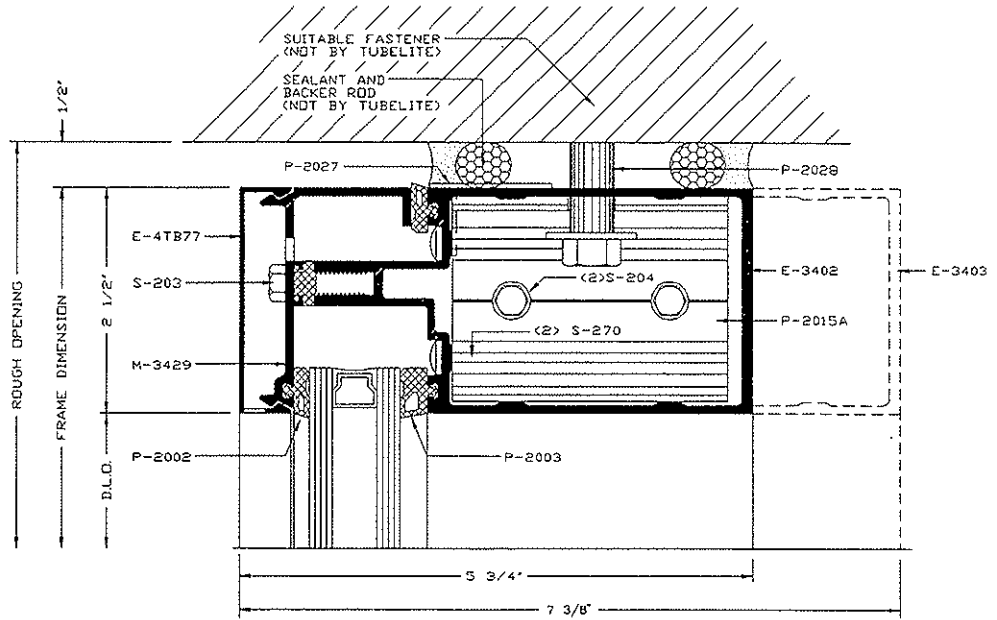

TYPICAL OUTSIDE  
GLAZE HORIZONTAL

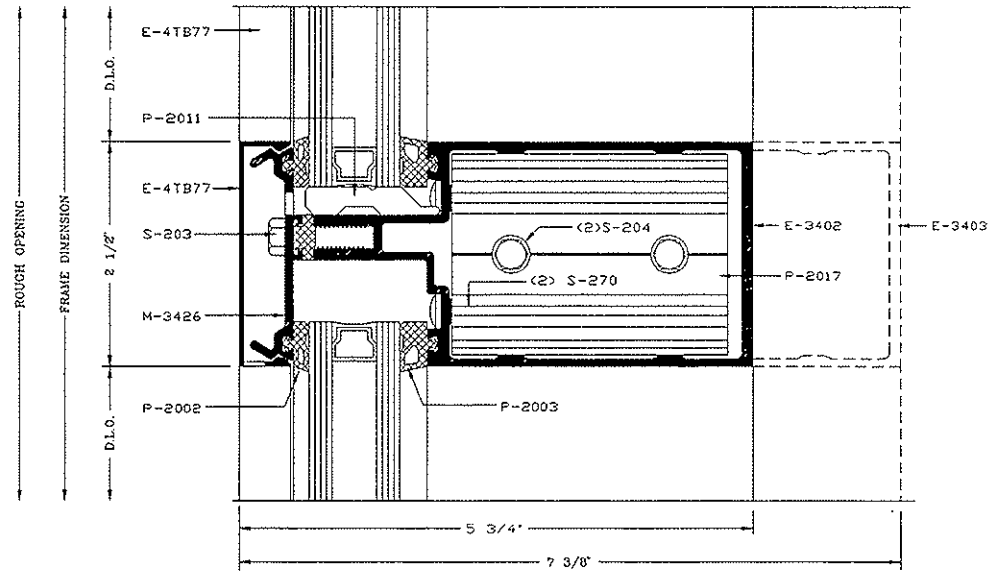

TYPICAL OUTSIDE  
GLAZE SILL

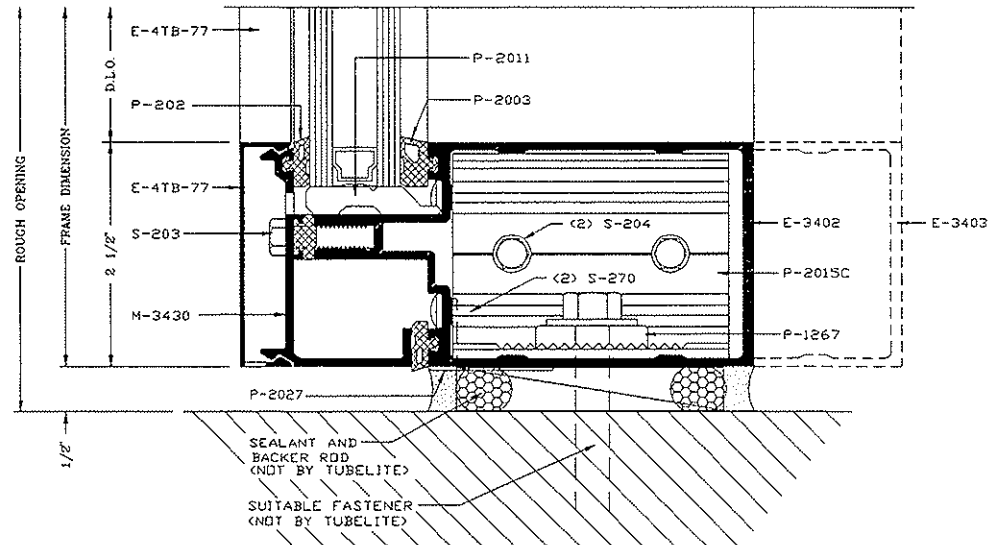

TYPICAL HORIZONTAL DETAILS / OUTSIDE GLAZED

ALTERNATE OUTSIDE  
GLAZE HEAD

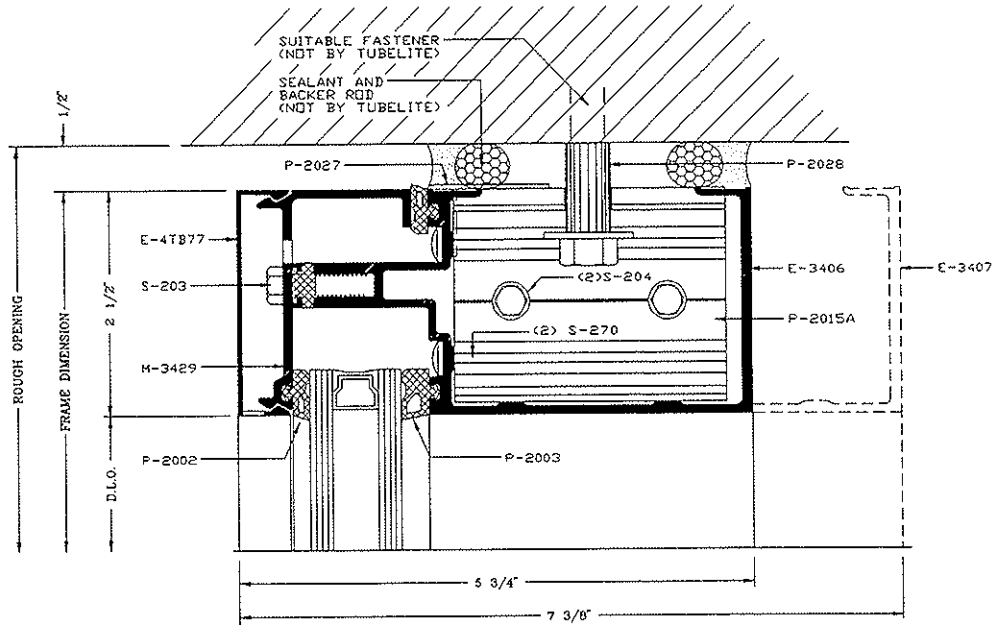

ALTERNATE OUTSIDE  
GLAZE HORIZONTAL

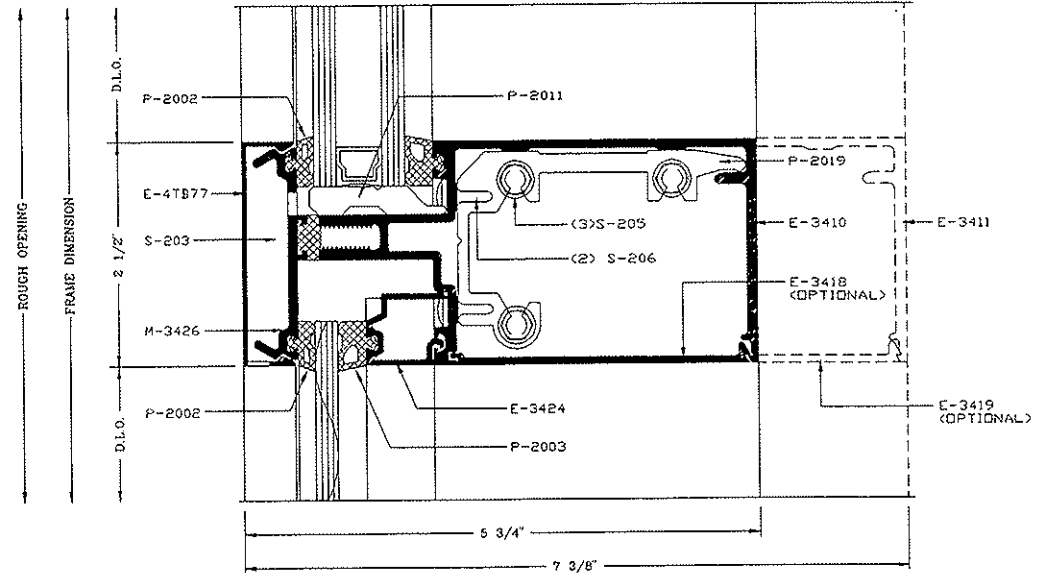

TYPICAL OUTSIDE  
GLAZE HORIZONTAL  
WITH SPANDREL GLASS

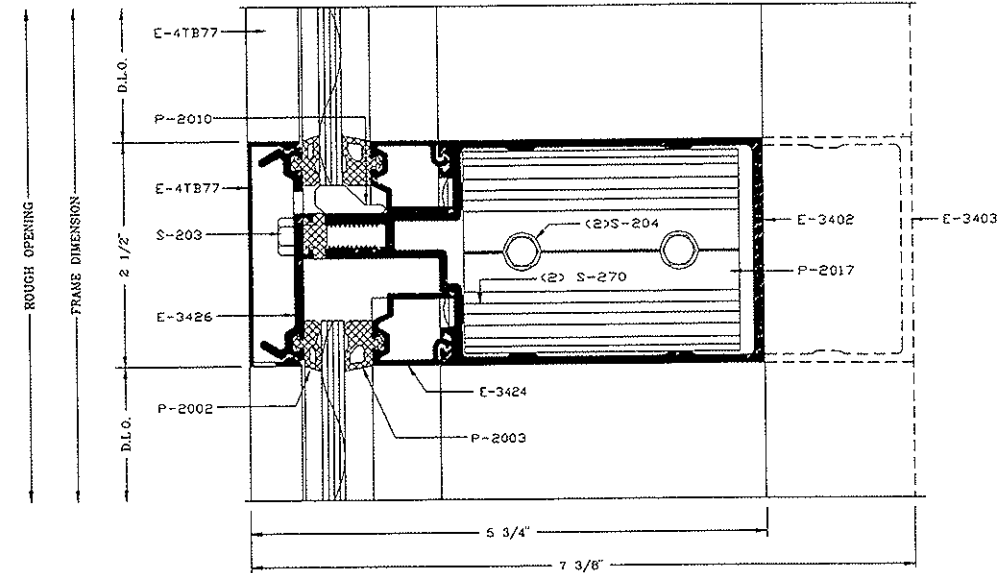

TYPICAL HORIZONTAL DETAILS / INSIDE GLAZED

TYPICAL INSIDE  
GLAZE HEAD

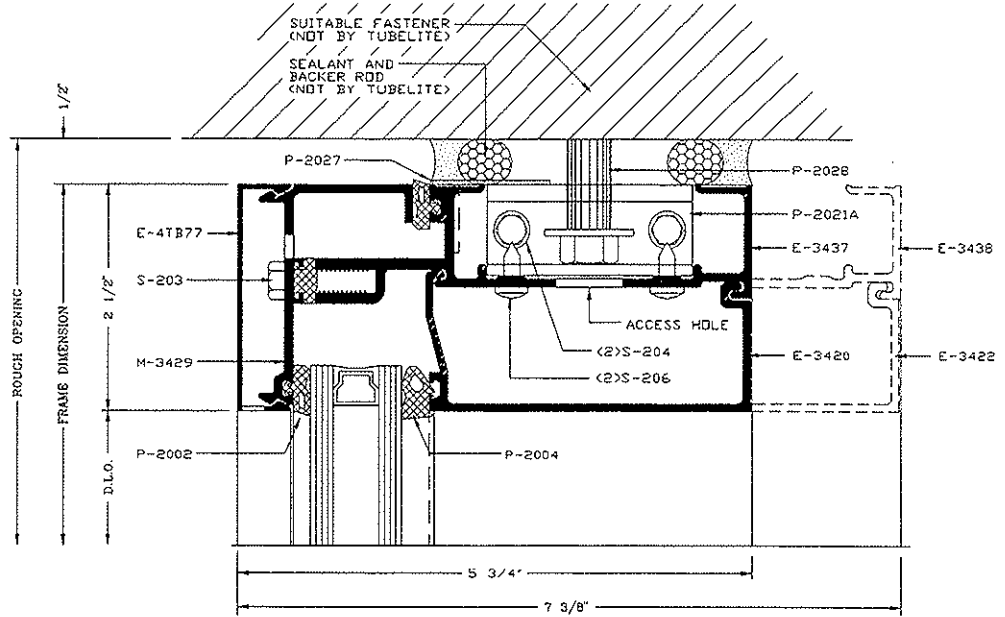

TYPICAL INSIDE  
GLAZE HORIZONTAL

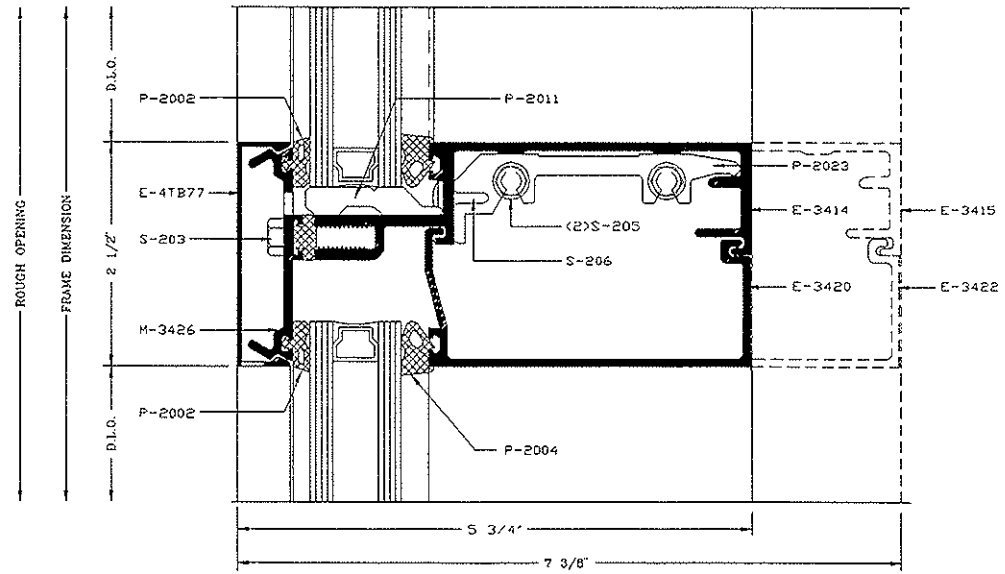

TYPICAL INSIDE  
GLAZE SILL

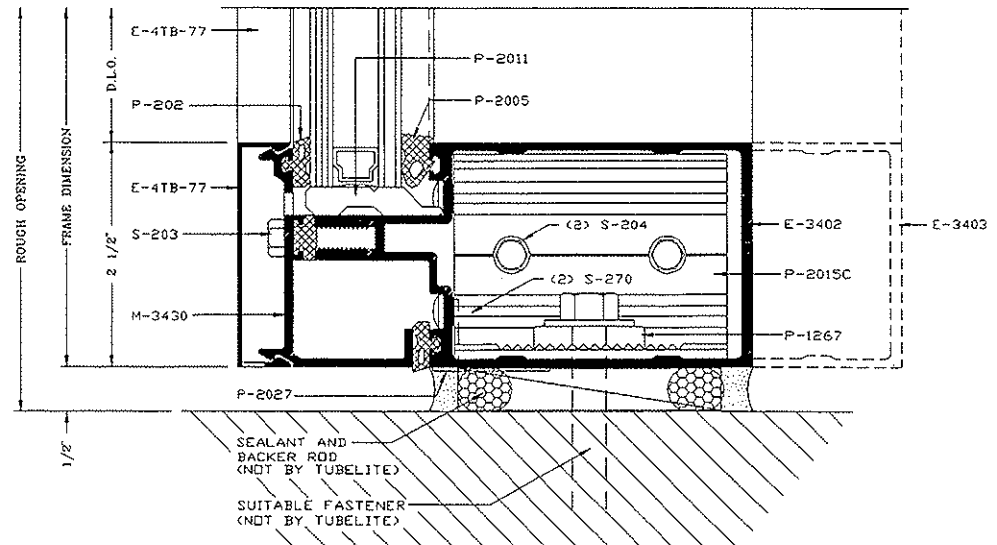

TYPICAL HORIZONTAL DETAILS / OUTSIDE GLAZED

TYPICAL INSIDE  
GLAZE HEAD  
WITH SPANDREL GLASS

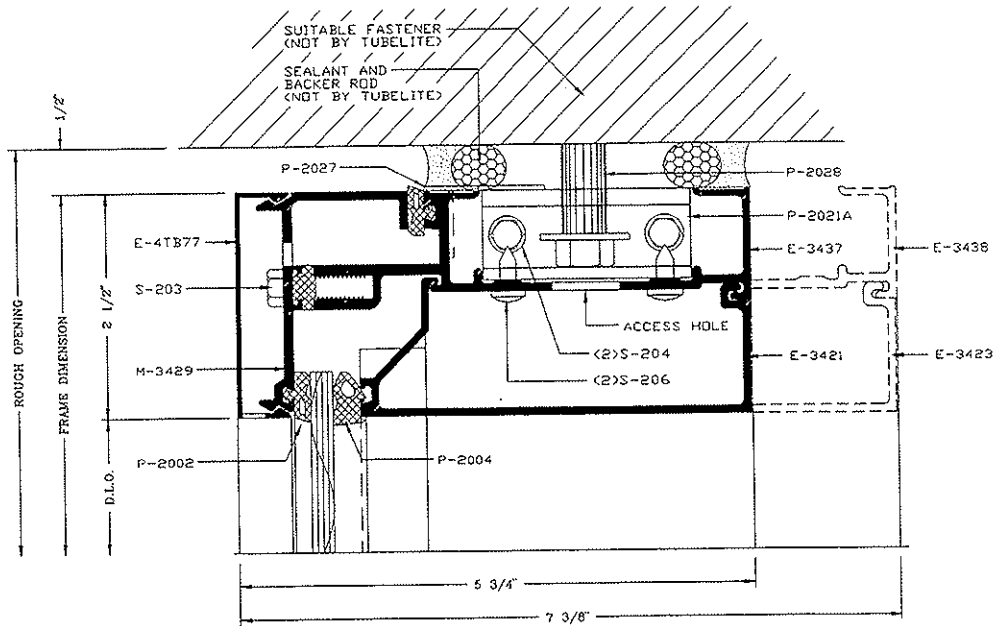

TYPICAL INSIDE  
GLAZE HORIZONTAL  
SPANDREL OVER VISION

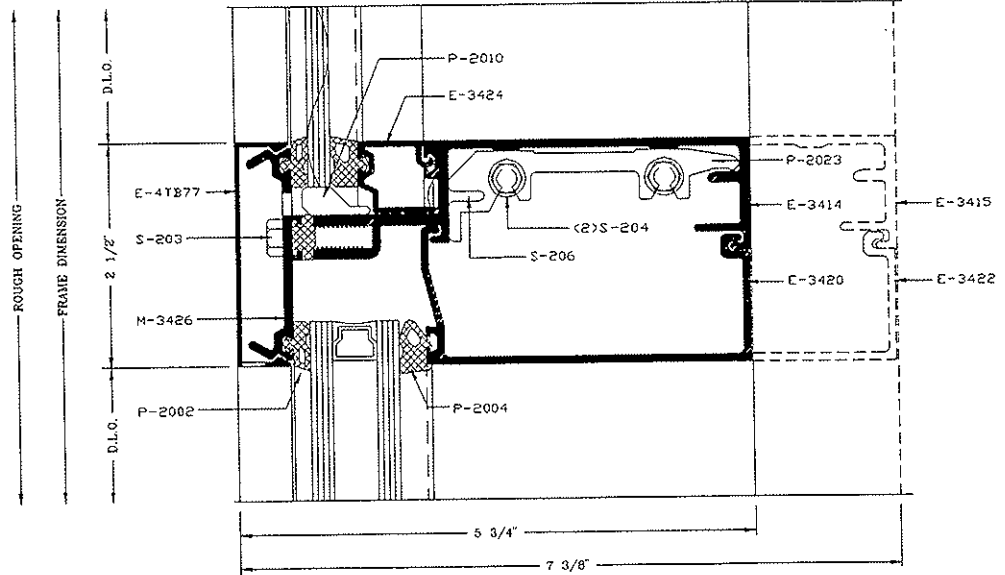

TYPICAL INSIDE  
GLAZE HORIZONTAL  
VISION OVER SPANDREL

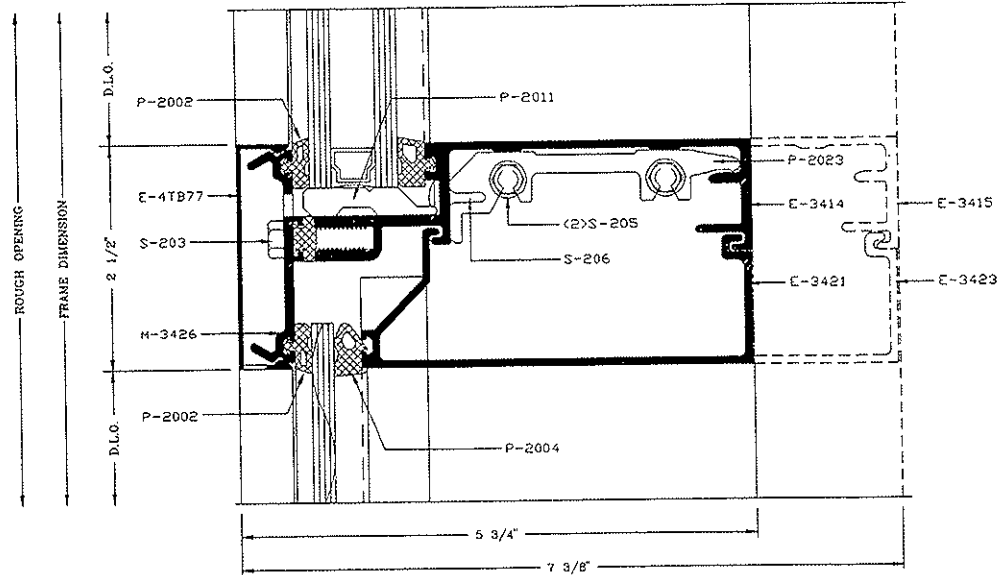

TYPICAL VERTICAL DETAILS / OUTSIDE GLAZED

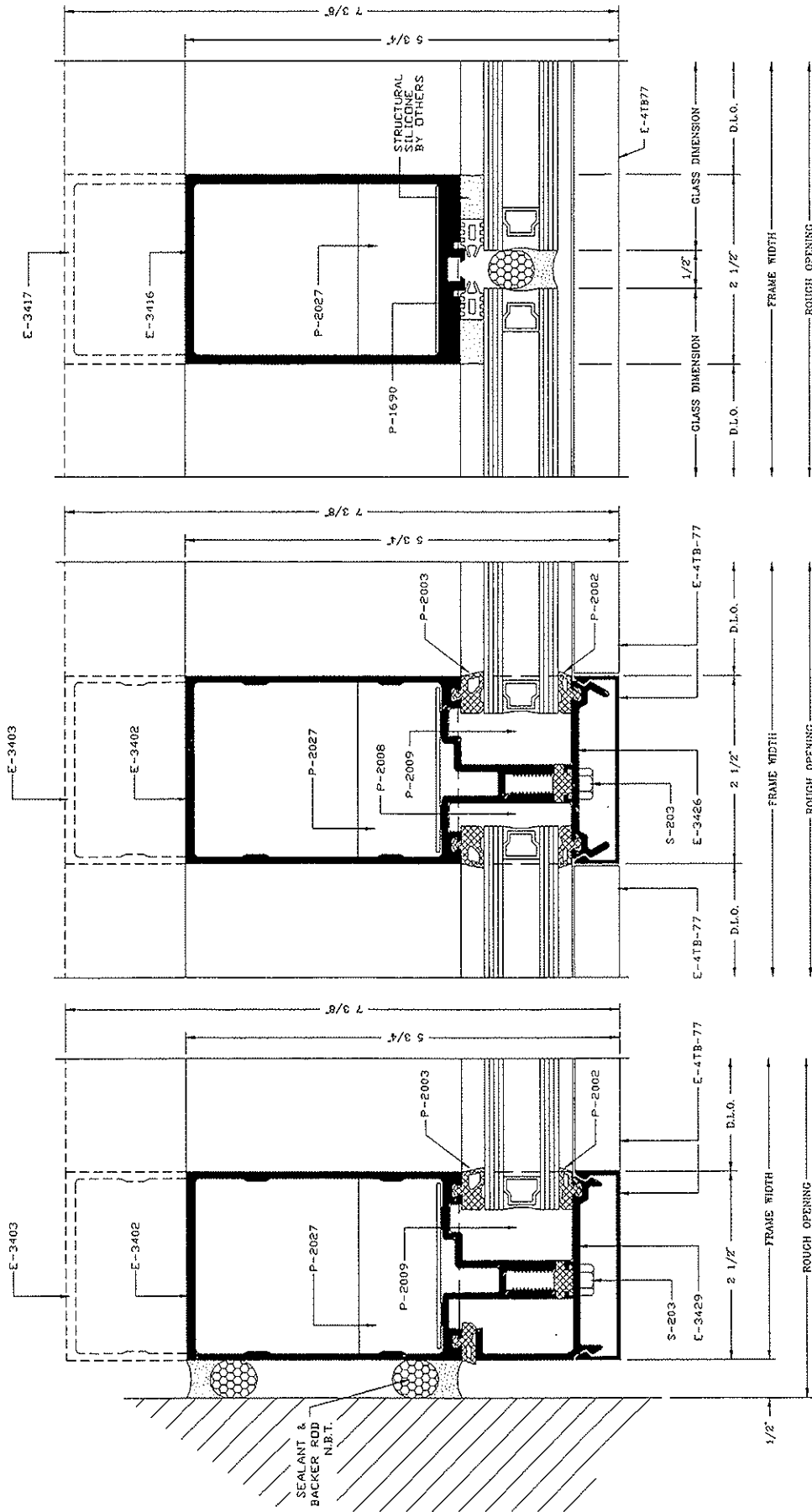

TYPICAL OUTSIDE GLAZE JAMB

TYPICAL OUTSIDE GLAZE MULLION

TYPICAL OUTSIDE GLAZE BUTT MULLION

TYPICAL VERTICAL DETAILS / OUTSIDE GLAZED

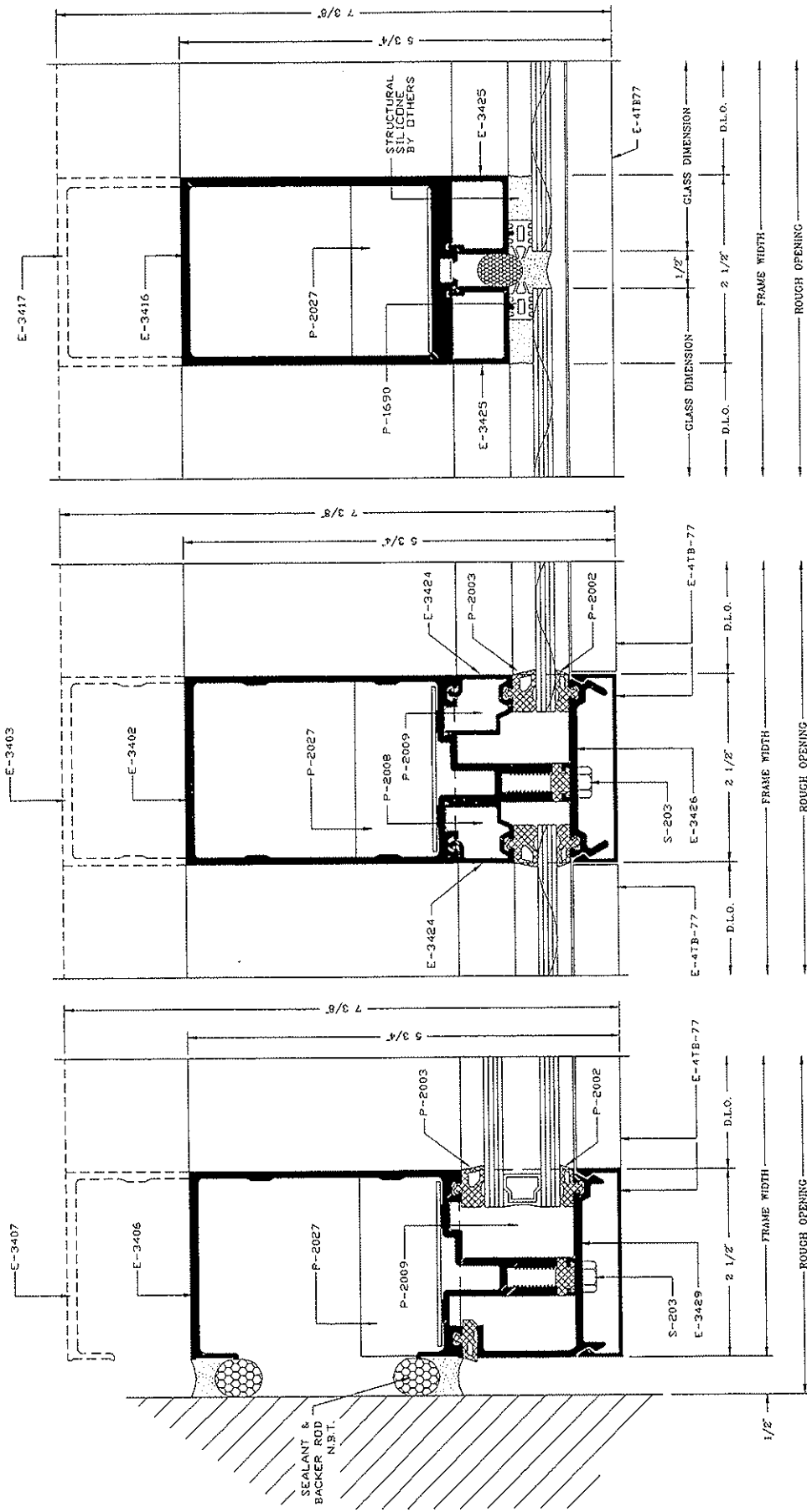

TYPICAL OUTSIDE  
GLAZE BUTT GLAZE MULLION  
WITH SPANDREL GLAZING

TYPICAL OUTSIDE  
GLAZE MULLION  
WITH SPANDREL GLAZING

ALTERNATE OUTSIDE  
GLAZE JAMB