

**AAMA 1503-98 THERMAL PERFORMANCE  
TEST REPORT**

**Rendered to:**

**TUBELITE, INC.**

**SERIES/MODEL: Tubelite Thermal Door**

**TYPE: Swinging Door with Frame**

<b>Summary of Results</b>	
Thermal Transmittance (U-Factor)	0.65
Condensation Resistance Factor - Frame (CRFf)	56
Condensation Resistance Factor - Glass (CRFg)	68
Glazing Description:	1/4" PPG Solarban 60 (e=0.035, #2) Tempered, 0.50" Gap, Azon Warm-Light® Spacer (A2), 90% Argon Filled*, 1/4" Clear Tempered

Reference should be made to ATI Report No. 79407.02-116-46 for complete test specimen description and data.

**AAMA 1503-98 THERMAL PERFORMANCE TEST REPORT**

Rendered to:

TUBELITE, INC.  
3056 Walker Ridge Drive NW Suite G  
Walker, Michigan 49544

Report No: 79407.02-116-46  
Test Date: 02/20/08  
Report Date: 02/28/08  
Expiration Date: 02/20/12

**Test Sample Identification:**

**Series/Model:** Tubelite Thermal Door

**Type:** Swinging Door with Frame

**Test Procedure:** The condensation resistance factor (CRF) and thermal transmittance (U) were determined in accordance with AAMA 1503-98, *Voluntary Test Method for Thermal Transmittance and Condensation Resistance of Windows, Doors and Glazed Wall Sections*

- |   |         |
|---|---------|
| 1. Average warm side ambient temperature                  | 69.80 F |
| 2. Average cold side ambient temperature                  | -0.39 F |
| 3. 15 mph dynamic wind applied to test specimen exterior. |         |
| 4. 0.0" $\pm$ 0.04" static pressure drop across specimen. |         |

**Test Results Summary:**

- |   |      |
|---|------|
| 1. Condensation resistance factor - Frame (CRF <sub>f</sub> ) | 56   |
| Condensation resistance factor - Glass (CRF <sub>g</sub> )    | 68   |
| 2. Thermal transmittance due to conduction (U <sub>c</sub> )  | 0.65 |
| (U-factors expressed in Btu/hr-ft <sup>2</sup> -F)            |      |

**Test Sample Description:**

<b>CONSTRUCTION</b>	<b>Frame</b>	<b>Panel</b>
Size (in.)	39-7/8" x 86"	35-1/2' x 83-1/4"
Daylight Opening (in.)	NA	25-3/4' x 67-1/4"
<b>CORNERS</b>	Butted	Butted
Fasteners	Screws	Screws
Sealant	No	No
<b>MATERIAL</b>	AT (0.22")	AT (0.22")
Color Exterior	Gray	Gray
Finish Exterior	Anodized	Anodized
Color Interior	Gray	Gray
Finish Interior	Anodized	Anodized
<b>GLAZING METHOD</b>	NA	Interior/Exterior

**Glazing Information**

<b>Layer 1</b>	1/4" PPG Solarban 60 (e=0.035, #2) Tempered
<b>Gap 1</b>	0.50" Gap, Azon Warm-Light® Spacer (A2), 90% Argon Filled*
<b>Layer 2</b>	1/4" Clear Tempered
<b>Gas Fill Method</b>	Single-Probe Timed*

*\*Stated per Client/Manufacturer*  
*NA Non-Applicable*  
*See Description Table Abbreviations*

**Test Sample Description:** (Continued)

<b>COMPONENTS</b>		
<b>Type</b>	<b>Quantity</b>	<b>Location</b>
<b>WEATHERSTRIP</b>		
Polypile with center fin	1 row	Head and jambs
Single-leaf gasket	1 row	Exterior bottom rail
<b>HARDWARE</b>		
Lock assembly	1	Lock stile
Pull handle	1	Exterior lock stile
Push bar	1	Interior lock stile
Full-mortise butt hinge	3	Hinge stile/jamb
Self closing mechanism	1	Interior head/top rail
Thermally broken aluminum jamb liners	2	Jambs
Aluminum threshold	1	Sill
<b>DRAINAGE</b>		
Sloped sill	1	Sill

**Test Duration:**

1. The environmental systems were started at 17:14 hrs., 02/19/08
2. The thermal performance test results were derived from 05:51 hrs., 02/20/08 to 07:51 hrs., 02/20/08.

**Condensation Resistance Factor (CRF):**

The following information, condensed from the test data, was used to determine the condensation resistance factor:

$T_h$	=	Warm side ambient air temperature	69.80 F
$T_c$	=	Cold side ambient air temperature	-0.39 F
$FT_p$	=	Average of pre-specified frame temperatures (14)	39.80 F
$FT_r$	=	Average of roving thermocouples (4)	31.73 F
$W$	=	$(FT_p - FT_r) / [FT_p - (T_c + 10)] \times 0.40$	0.107
$FT$	=	$FT_p(1-W) + W (FT_r) =$ Frame Temperature	38.94 F
$GT$	=	Glass Temperature	47.55 F
$CRF_g$	=	Condensation resistance factor – Glass	68
		$CRF_g = (GT - T_c) / (T_h - T_c) \times 100$	
$CRF_f$	=	Condensation resistance factor – Frame	56
		$CRF_f = (FT - T_c) / (T_h - T_c) \times 100$	

The CRF number was determined to be 56 (on the size as reported). When reviewing this test data, it should be noted that the frame temperature (FT) was colder than the glass temperature (GT) therefore controlling the CRF number. Refer to the 'CRF Report' page and the 'Thermocouple Location Diagram' page of this report.

**Thermal Transmittance ( $U_c$ ):**

$T_h$ = Average warm side ambient temperature	69.80 F
$T_c$ = Average cold side ambient temperature	-0.39 F
$P$ = Static pressure difference across test specimen 15 mph dynamic perpendicular wind at exterior	0.00 psf
Nominal sample area	23.81 ft <sup>2</sup>
Total measured input to calorimeter	1198.64 Btu/hr
Calorimeter correction	110.85 Btu/hr
Net specimen heat loss	1087.79 Btu/hr
$U_c$ = Thermal Transmittance	0.65 Btu/hr-ft <sup>2</sup> -F

**Glazing Deflection (in.):**

	Panel
Actual Gap Width	0.50
Effective gap width upon receipt of specimen in laboratory (after stabilization)	0.50
Effective gap width at laboratory ambient conditions on day of testing	0.50
Effective gap width at test conditions	0.44

The test sample was inspected for the formation of frost or condensation which may influence the surface temperature measurements. Any observed condensation/frost is indicated on the 'Thermocouple Location Diagram.'

A calibration of the ATI 'thermal test chamber' in York, Pennsylvania was conducted in March 2007.



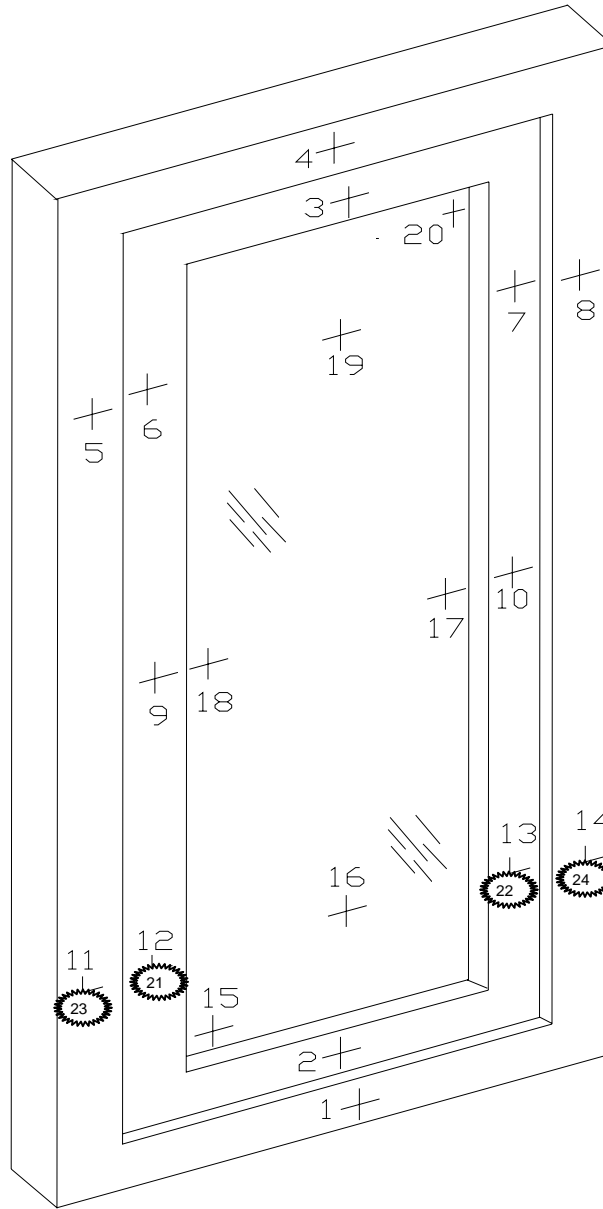

## CRF Report

Time:	05:51	06:21	06:51	07:21	07:51	AVERAGE
<b>Pre-specified Thermocouples - Frame</b>						
1	35.84	35.88	35.99	36.02	35.97	35.94
2	34.55	34.58	34.68	34.74	34.69	34.65
3	47.38	47.40	47.48	47.56	47.52	47.47
4	54.94	54.99	55.07	55.07	55.05	55.02
5	46.26	46.29	46.37	46.39	46.42	46.35
6	41.88	41.90	41.93	41.98	42.00	41.94
7	43.88	43.89	43.92	43.94	43.92	43.91
8	48.07	48.12	48.13	48.19	48.12	48.13
9	38.43	38.45	38.48	38.48	38.53	38.47
10	38.43	38.45	38.48	38.48	38.53	38.47
11	32.47	32.51	32.57	32.54	32.52	32.52
12	29.72	29.78	29.77	29.78	29.73	29.76
13	31.38	31.38	31.43	31.41	31.48	31.42
14	33.16	33.23	33.26	33.27	33.21	33.23
FTP	39.74	39.77	39.82	39.85	39.84	39.80
<b>Pre-specified Thermocouples - Glass</b>						
15	34.71	34.77	34.78	34.78	34.73	34.75
16	55.26	55.36	55.33	55.33	55.33	55.32
17	44.39	44.36	44.41	44.44	44.43	44.41
18	42.85	42.86	42.95	42.88	42.91	42.89
19	58.24	58.29	58.33	58.32	58.31	58.30
20	49.67	49.69	49.70	49.58	49.60	49.65
GT	47.52	47.55	47.58	47.56	47.55	47.55
<b>Cold Point (Roving) Thermocouples</b>						
21	29.80	29.80	29.80	29.80	29.80	29.80
22	31.40	31.40	31.40	31.40	31.40	31.40
23	32.50	32.50	32.50	32.50	32.50	32.50
24	33.20	33.20	33.20	33.20	33.20	33.20
FT <sub>R</sub>	31.73	31.73	31.73	31.73	31.73	31.73
W	0.11	0.11	0.11	0.11	0.11	0.107
FT	38.89	38.92	38.96	38.97	38.97	38.94
<b>Warm Side - Room Ambient Air Temperature</b>						
	69.80	69.81	69.82	69.81	69.79	69.80
<b>Cold Side - Room Ambient Air Temperature</b>						
	-0.38	-0.40	-0.37	-0.42	-0.39	-0.39
CRF <sub>f</sub>	55.96	56.00	56.03	56.09	56.08	56
CRF <sub>g</sub>	68.26	68.30	68.32	68.31	68.31	68

**Thermocouple Location Diagram**



**Cold Point Locations**

	21. 29.80
	22. 31.40
	23. 32.50
	24. 33.20

Detailed drawings, representative samples of the test specimen and a copy of this report will be retained by ATI for a period of four years. This report is the exclusive property of the client so named herein and relates only to the fenestration product tested. This report may not be reproduced, except in full, without the approval of the laboratory. Results obtained are tested values and do not constitute an opinion or endorsement by this laboratory.

For ARCHITECTURAL TESTING, INC.

---

Ryan P. Moser  
Technician

---

Michael J. Thoman  
Director - Simulations and Thermal  
Individual-In-Responsible-Charge

RPM:kmm  
79407.02-116-46

Attachments:  
Table, Drawings and Bill of Materials, (4)

### Revision Log

<u>Rev. #</u>	<u>Date</u>	<u>Page(s)</u>	<u>Revision(s)</u>
.02R0	02/28/08	All	Original Report Issue. Work requested by Nancy Kennedy of Tubelite, Inc..

## Description Table Abbreviations

CODE	Frame / Sash Types
AI	Aluminum w/ Vinyl Inserts (Caps)
AL	Aluminum
AP	Aluminum w/ Thermal Breaks - Partial
AS	Aluminum w/ Steel Reinforcement
AT	Aluminum w/ Thermal Breaks - All Members ( $\geq 0.21"$ )
AU	Aluminum Thermally Improved - All Members (0.062" - 0.209")
AV	Aluminum / Vinyl Composite
AW	Aluminum-clad Wood
FG	Fiberglass
PA	ABS Plastic w/ All Members Reinforced
PC	ABS Plastic-clad Aluminum
PF	ABS Plastic w/ Foam-filled Insulation
PH	ABS Plastic w/ Horizontal Members Reinforced
PI	ABS Plastic w/ Reinforcement - Interlock
PL	ABS Plastic
PP	ABS Plastic w/ Reinforcement - Partial
PV	ABS Plastic w/ Vertical Members Reinforced
PW	ABS Plastic-clad Wood
ST	Steel
VA	Vinyl w/ All Members Reinforced
VC	Vinyl-clad Aluminum
VF	Vinyl w/ Foam-filled Insulation
VH	Vinyl w/ Horizontal Members Reinforced
VI	Vinyl w/ Reinforcement - Interlock
VP	Vinyl w/ Reinforcement - Partial
VV	Vinyl w/ Vertical Members Reinforced
VW	Vinyl-clad Wood
VY	Vinyl
WA	Aluminum / Wood composite
WD	Wood
WV	Vinyl / Wood composite
WF	Fiberglass/Wood Combination
WC	Composite/Wood Composite (Shaped vinyl/wood composite members)
CW	Copper Clad Wood
CO	Vinyl/Wood Composite Material

DOOR DETAILS	
N	Not Applicable
CODE	Door Type
EM	Embossed
FL	Flush
LF	Full Lite
LH	1/2 - Lite
LQ	1/4 - Lite
LT	3/4 - Lite
RP	Raised Panel
CODE	Skin
AL	Aluminum
FG	Fiberglass
GS	Galvanized Steel
ST	Steel
WD	Wood
VY	Vinyl
CODE	Panel
FG	Fiberglass
PL	Plastic
WP	Wood - Plywood
WS	Wood - Solid
CODE	Sub-Structure
GS	Galvanized Steel
ST	Steel
WD	Wood
VY	Vinyl
CODE	Core Fill
CH	Cellular - Honeycomb
EP	Expanded Polystyrene
PI	Polyisocyanurate
PU	Polyurethane
WP	Wood - Plywood
WS	Wood - Solid
XP	Extruded Polystyrene

CODE	Spacer Sealant
D	Dual Seal Spacer System
S	Single Seal Spacer System

CODE	Grid Description
N	No Muntins
G	Grids between glass
S	Simulated Divided Lites
T	True Muntins

CODE	Grid Size Codes
	Blank for no grids
0.75	Grids < 1"
1.5	Grids $\geq 1"$

CODE	Thermal Breaks
F	Foam
U	Urethane
V	Vinyl
FB	Fiberglass
O	Other
AB	ABS
NE	Neoprene
AI	Air
N	Not Applicable
P	Polyamide

CODE	Tint Codes
AZ	Azurlite
BL	Blue
BZ	Bronze
CL	Clear
EV	Evergreen
GD	Gold
GR	Green
GY	Gray
LE	Low 'e' Coating
OT	Other (use comment field)
RC	Solar or Reflective Coating
RG	Roller Shades between glazing
RS	Silver (reflective coating)
SF	Suspended Polyester Film
SR	Silver
BG	Blinds between the Glazing
DV	Dynamic Glazing-Variable
DY	Dynamic Glazing-NonVariable

CODE	Gap Fill Codes
AIR	Air
AR2	Argon/Krypton Mixture
AR3	Argon / Krypton / Air
ARG	Argon/Air
CO2	Carbon Dioxide
KRY	Krypton/Air
SF6	Sulfur Hexafluoride
XE2	Xenon/Krypton/Air
XE3	Xenon/Argon/Air
XEN	Xenon/Air
N	Not Applicable

CODE	Spacer Types (See sealant)
A1	Aluminum
A2	Aluminum (Thermally-broken)
A3	Aluminum-reinforced Polymer
A4	Aluminum / Wood
A5	Aluminum-reinforced Butyl (Swiggle)
A6	Aluminum / Foam / Aluminum
A7	Aluminum U-shaped
A8	Aluminum-Butyl (Corrugated) (Duraseal)
ER	EPDM Reinforced Butyl
FG	Fiberglass
GL	Glass
OF	Organic Foam
PU	Polyurethane Foam
SU	Stainless Steel, U-shaped
CU	Coated Steel, U-shaped (Intercept)
S2	Steel (Thermally-broken)
S3	Steel / Foam / Steel
S5	Steel-reinforced Butyl
S6	Steel U-channel w/ Thermal Cap
SS	Stainless Steel
CS	Coated Steel
TP	Thermo-plastic
WD	Wood
ZF	Silicone Foam
ZS	Silicone / Steel
N	Not Applicable
TS	Thermo-plastic w/ stainless steel substrate

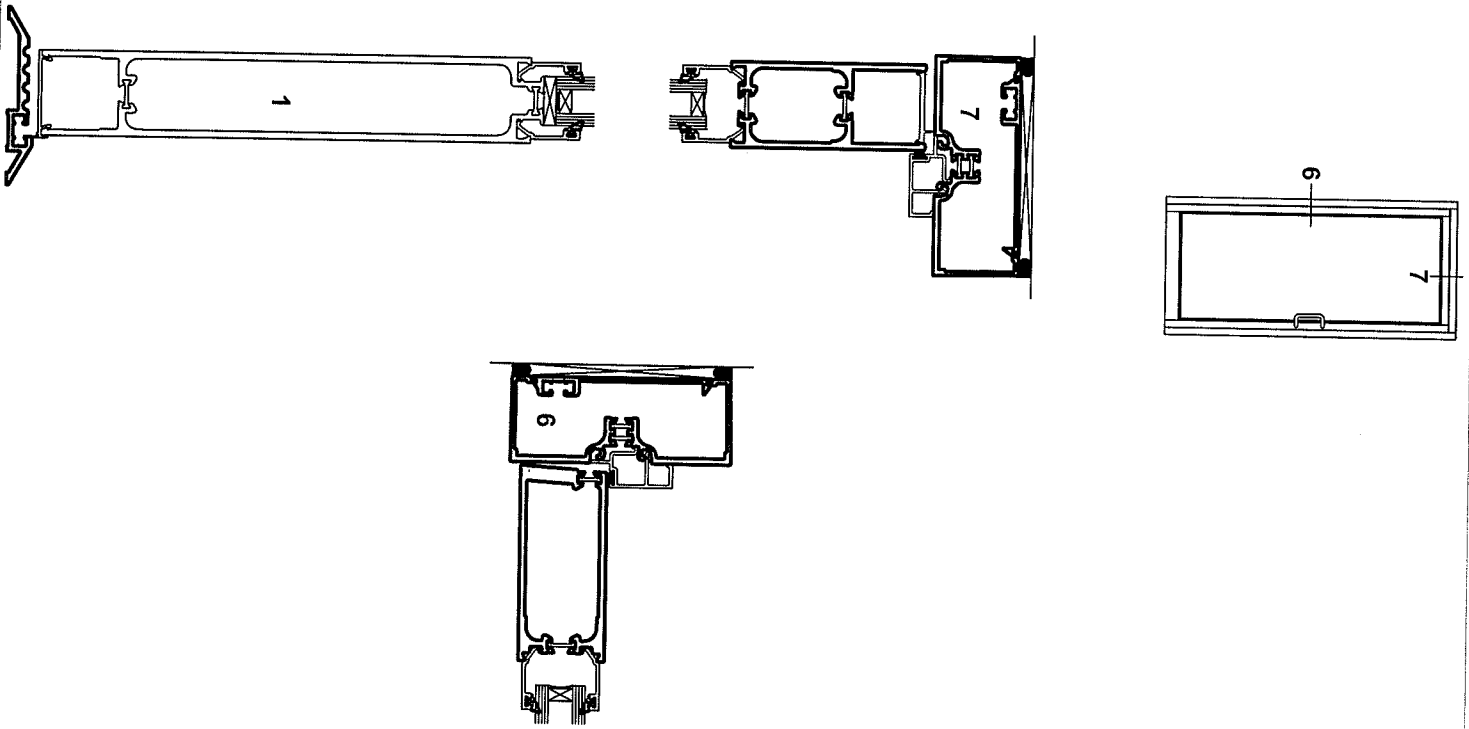

**Architectural Testing**

Test sample complies with these details.  
Deviations are noted.

Report# 79407  
Date: 2/28/09 Tech PPM

# Butt Hinge Frame Assembly (Left Hand Shown)

Allow for 1/4" shim and sealant space at sides and top of door frame. Door opening must be plumb

1. Attach header (and transom if required) with provided screws into the splines. See Figure 1.
2. Attach threshold clips with provided screws. See Figures 2 & 3.
3. Set frame into opening and ensure that it is plumb and square.
4. Drill anchor holes in glazing pocket of both vertical jamba as indicated by arrows, if no adjustment. Add a center anchor location for a 3 Butt or Continuous Hinge application.
5. Secure vertical jamb to opening. (Screws not provided)
6. Install backer rod or insulation between frame and building opening then seal.
7. Attach threshold, onto a bed of sealant, to floor using the #12 anchor screws provided. See

Ensure that the threshold is supported the entire length of threshold, if not shim as required.

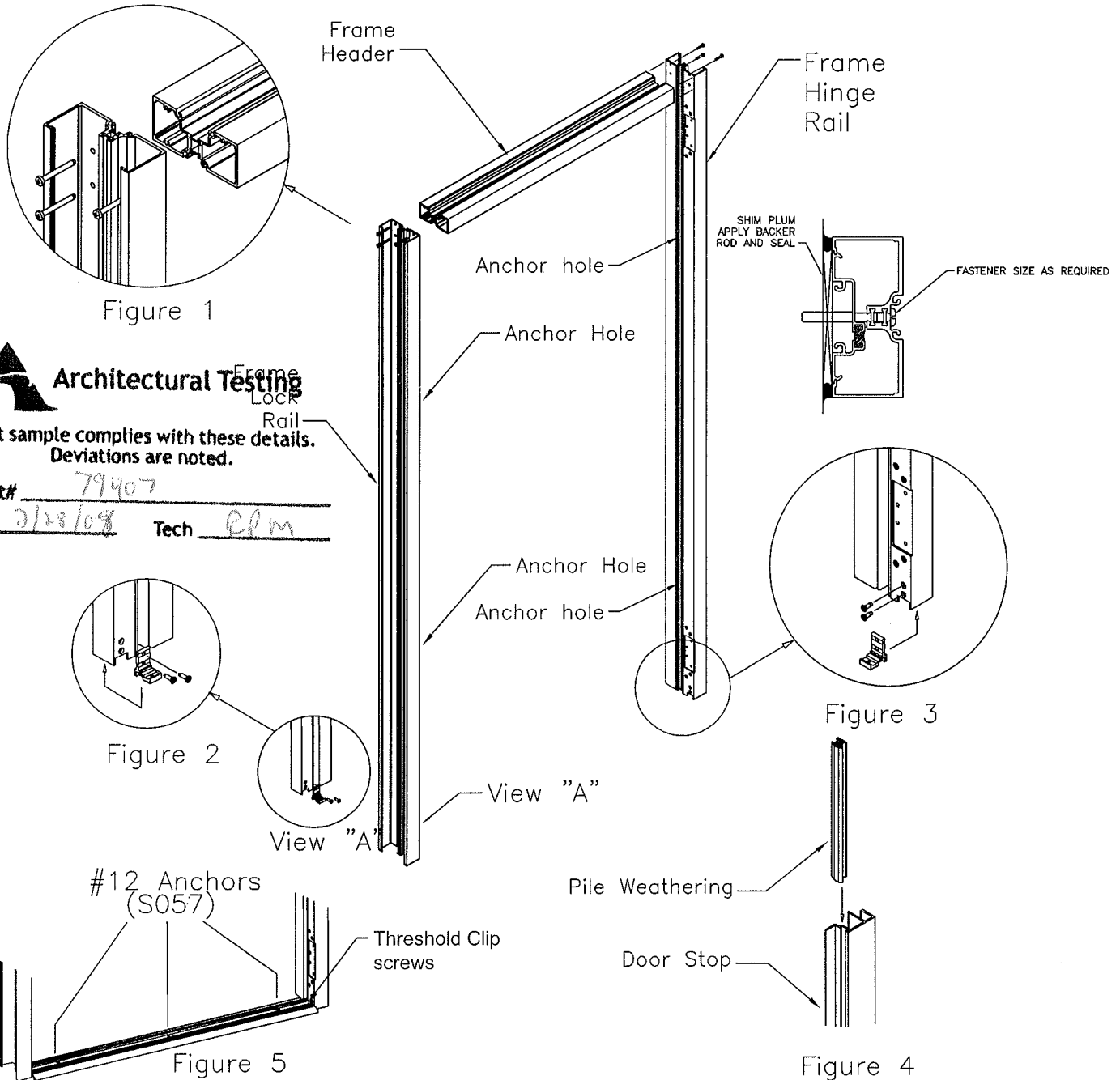

**Architectural Testing**  
 Test sample complies with these details.  
 Deviations are noted.  
 Report# 79407  
 Date: 2/23/08 Tech ELM

## Thermal Frame Assembly

Check opening allow for 1/4" shim and sealant space at sides and top of door frame. Door opening must be plumb and square

1. Attach header (and transom if required) with provided screws into the splines utilizing the templat provided. See figure 1 & 2.
2. Attach threshold clips with provided screws. See figure 3 for threshold attachment and figure 4 for vestibule or no-threshold option.

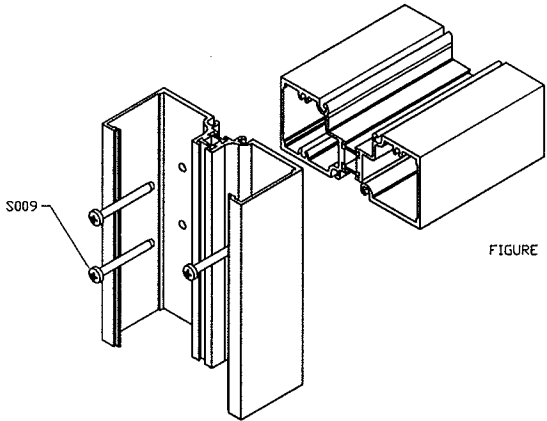
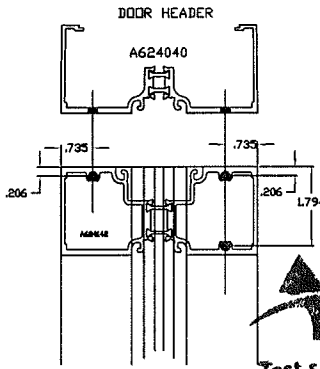

FIGURE 1



**Architectural Testing**  
 Test sample complies with these details.  
 Deviations are noted.

Report# 79407  
 Date 7/28/03 Tech RPM

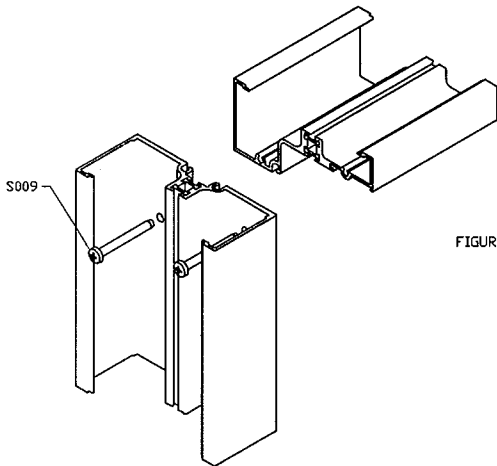
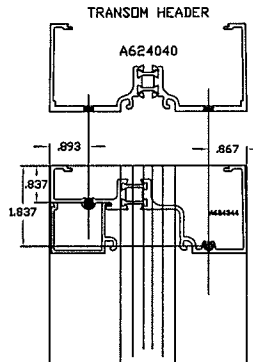

FIGURE 2



## Thermal Frame Butt Hinge Prep Only

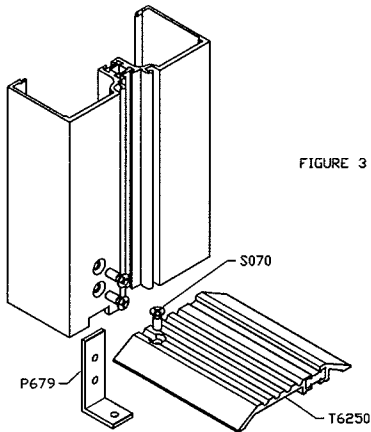

FIGURE 3

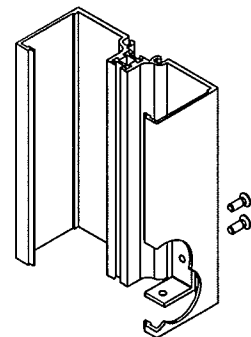
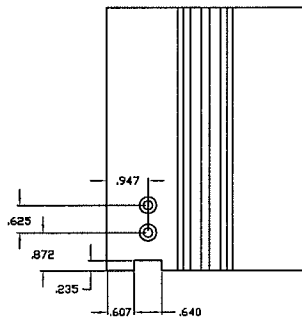

FIGURE 4