



**AAMA 507-07 THERMAL PERFORMANCE REPORT**

**Rendered to:**

**TUBELITE, INC.**

**SERIES/MODEL: Standard 1-3/4" Wide Stile Single Door**

**TYPE: Swinging Door - Single**

**Report No: B3772.20-116-45**  
**Report Date: 10/27/11**

## AAMA 507-07 THERMAL PERFORMANCE REPORT

Rendered to:

TUBELITE, INC.  
4878 Mackinaw Trail  
Reed City, Michigan 49677

Report No: B3772.20-116-45  
Report Date: 10/27/11  
Simulation Date: 10/27/11

### Project Summary:

Architectural Testing, Inc. was contracted by Tubelite, Inc. to provide U-Factor and Solar Heat Gain Coefficient thermal performance ratings on the Standard 1-3/4" Wide Stile Single Door Swinging Door - Single. The thermal performance ratings were determined in accordance with AAMA 507-07, Standard Practice for Determining the Thermal Performance Characteristics of Fenestration Systems Installed in Commercial Building.

### Reference Documents:

*AAMA 507-07, Standard Practice for Determining the Thermal Performance Characteristics of Fenestration Systems Installed in Commercial Buildings*

*NFRC 100-2010, Procedure for Determining Fenestration Product U-Factors*

*NFRC 200-2010, Procedure for Determining Fenestration Product Solar Heat Gain Coefficient and Visible Transmittance at Normal Incidence*

### Simulation Specimen Description:

**Series/Model:** Standard 1-3/4" Wide Stile Single Door  
**Product Groupings:** 1-3/4" Wide w/o sweep grouped with 1-3/4" Wide w/ sweep.  
**Type:** Swinging Door - Single  
**Frame Material:** Aluminum Framing System  
**Material Finish:** Painted Aluminum  
**Specimen Size:** 960mm wide by 2090mm high (37-3/4" by 82-3/8")  
**Configuration:** Single vision Ilte  
**Drawing Reference:** Tubelite Standard Doors - 2" Frame Details

**Tubelite, Inc.**  
**Standard 1-3/4" Wide Stile Single Door - Swinging Door - Single**

**System U-Factor vs. Percentage of Vision Area**

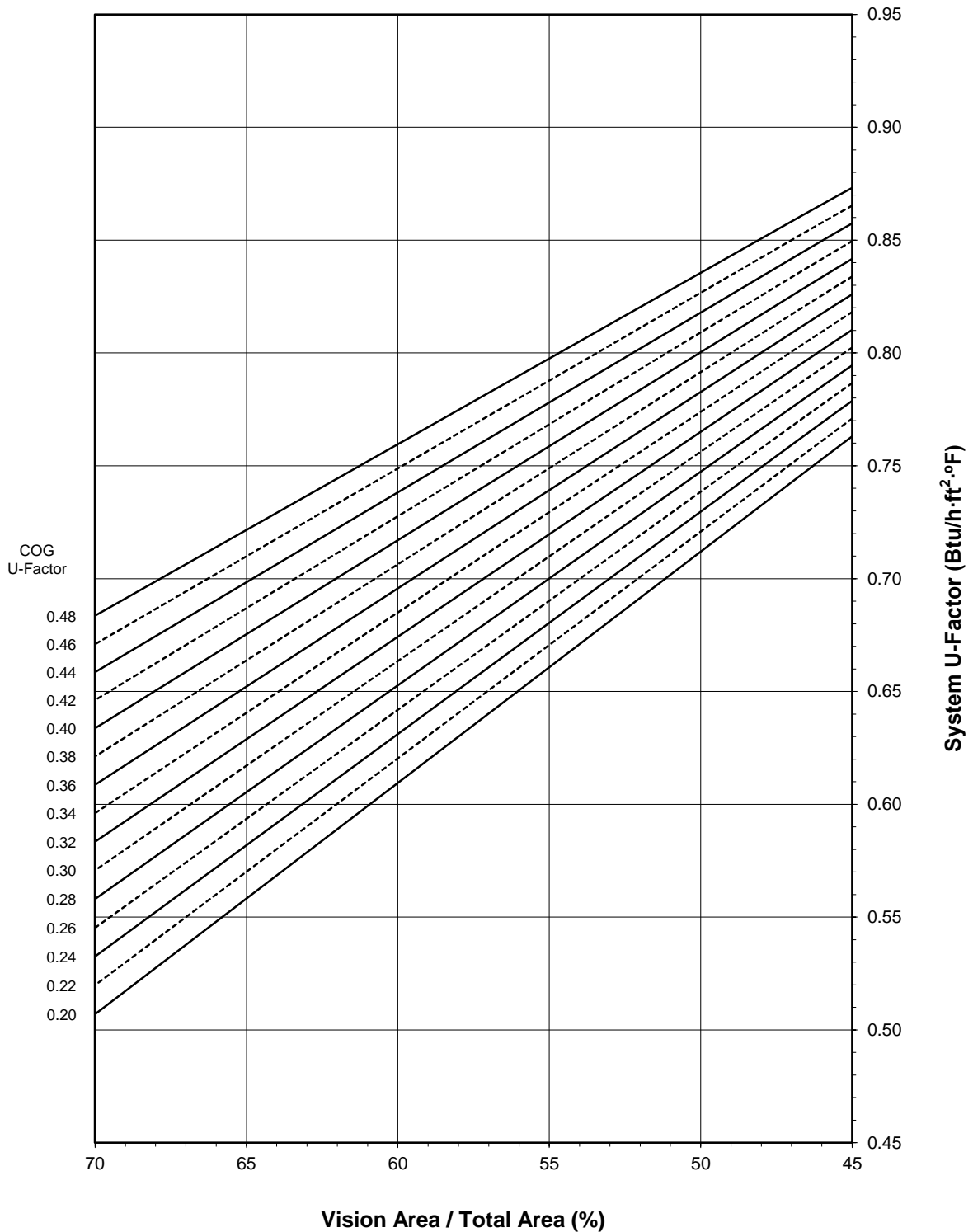

Note: 1 inch Overall - Dual Glazed Glass (0.48-0.20 COG) with Aluminum Spacer



**Tubelite, Inc.**  
**Standard 1-3/4" Wide Stile Single Door - Swinging Door - Single**

**Size Specific U-Factor Matrix\***

Glazing Option	Center of Glass U-Factor	Overall U-Factor
1	0.48	0.86
2	0.46	0.85
3	0.44	0.84
4	0.42	0.84
5	0.40	0.83
6	0.38	0.82
7	0.36	0.81
8	0.34	0.80
9	0.32	0.80
10	0.30	0.79
11	0.28	0.78
12	0.26	0.77
13	0.24	0.76
14	0.22	0.75
15	0.20	0.75

Note: 1 inch Overall - Dual Glazed Glass (0.48-0.20 COG) with Aluminum Spacer

**Size Specific SHGC Matrix\***

Center of Glass SHGC	Overall SHGC
0.75	0.40
0.70	0.37
0.65	0.35
0.60	0.33
0.55	0.30
0.50	0.28
0.45	0.26
0.40	0.23
0.35	0.21
0.30	0.19
0.25	0.16
0.20	0.14
0.15	0.12
0.10	0.09
0.05	0.07

**Size Specific VT Matrix\***

Center of Glass VT	Overall VT
0.75	0.35
0.70	0.33
0.65	0.30
0.60	0.28
0.55	0.26
0.50	0.23
0.45	0.21
0.40	0.19
0.35	0.16
0.30	0.14
0.25	0.12
0.20	0.09
0.15	0.07
0.10	0.05
0.05	0.02

\*Size Specific U-Factor, SHGC, and VT Matrices are based on the standard Swinging Door - Single specimen size of 960mm wide by 2090mm high (37-3/4" by 82-3/8"). This represents 46.7% Vision Area / Total Area.

Vision Area Data

Option No.	COG U-Factor	COG Temperature	Cross Section	Frame Height	Frame U-Factor	Edge U-Factor	Total Product U-Factor		
							45% Vision Area	NFRC 100-2010	70% Vision Area
							36.42" by 79.29"	37.80" by 82.28"	72.11" by 156.99"
1	0.48	43.7	Head	7.9645	1.1940	0.5767	0.8732	0.8607	0.6836
			L. Jamb	7.9056	1.1829	0.5785			
			R. Jamb	7.9056	1.1829	0.5785			
			Sill	8.2770	1.1346	0.5812			
2	0.46	44.8	Head	7.9645	1.1939	0.5631	0.8653	0.8525	0.6710
			L. Jamb	7.9056	1.1829	0.5650			
			R. Jamb	7.9056	1.1829	0.5650			
			Sill	8.2770	1.1344	0.5675			
3	0.44	45.8	Head	7.9645	1.1939	0.5495	0.8574	0.8443	0.6586
			L. Jamb	7.9056	1.1828	0.5514			
			R. Jamb	7.9056	1.1828	0.5514			
			Sill	8.2770	1.1343	0.5539			
4	0.42	46.8	Head	7.9645	1.1938	0.5362	0.8496	0.8361	0.6462
			L. Jamb	7.9056	1.1828	0.5380			
			R. Jamb	7.9056	1.1828	0.5380			
			Sill	8.2770	1.1342	0.5404			
5	0.40	47.9	Head	7.9645	1.1938	0.5228	0.8417	0.8280	0.6337
			L. Jamb	7.9056	1.1827	0.5247			
			R. Jamb	7.9056	1.1827	0.5247			
			Sill	8.2770	1.1341	0.5270			
6	0.38	48.9	Head	7.9645	1.1937	0.5096	0.8339	0.8198	0.6212
			L. Jamb	7.9056	1.1827	0.5115			
			R. Jamb	7.9056	1.1827	0.5115			
			Sill	8.2770	1.1340	0.5136			
7	0.36	50.0	Head	7.9645	1.1937	0.4963	0.8260	0.8116	0.6087
			L. Jamb	7.9056	1.1826	0.4983			
			R. Jamb	7.9056	1.1826	0.4983			
			Sill	8.2770	1.1338	0.5002			
8	0.34	51.0	Head	7.9645	1.1936	0.4833	0.8182	0.8034	0.5961
			L. Jamb	7.9056	1.1826	0.4853			
			R. Jamb	7.9056	1.1826	0.4853			
			Sill	8.2770	1.1337	0.4872			
9	0.32	52.0	Head	7.9645	1.1936	0.4701	0.8103	0.7952	0.5835
			L. Jamb	7.9056	1.1825	0.4721			
			R. Jamb	7.9056	1.1825	0.4721			
			Sill	8.2770	1.1336	0.4740			
10	0.30	53.1	Head	7.9645	1.1936	0.4572	0.8024	0.7870	0.5708
			L. Jamb	7.9056	1.1825	0.4591			
			R. Jamb	7.9056	1.1825	0.4591			
			Sill	8.2770	1.1335	0.4610			

Vision Area Data

Option No.	COG U-Factor	COG Temperature	Cross Section	Frame Height	Frame U-Factor	Edge U-Factor	Total Product U-Factor		
							45% Vision Area	NFRC 100-2010	70% Vision Area
							36.42" by 79.29"	37.80" by 82.28"	72.11" by 156.99"
11	0.28	54.2	Head	7.9645	1.1935	0.4441	0.7945	0.7788	0.5581
			L. Jamb	7.9056	1.1825	0.4461			
			R. Jamb	7.9056	1.1825	0.4461			
			Sill	8.2770	1.1334	0.4479			
12	0.26	55.2	Head	7.9645	1.1935	0.4312	0.7866	0.7706	0.5453
			L. Jamb	7.9056	1.1825	0.4332			
			R. Jamb	7.9056	1.1825	0.4332			
			Sill	8.2770	1.1333	0.4349			
13	0.24	56.3	Head	7.9645	1.1935	0.4183	0.7788	0.7624	0.5326
			L. Jamb	7.9056	1.1824	0.4204			
			R. Jamb	7.9056	1.1824	0.4204			
			Sill	8.2770	1.1332	0.4220			
14	0.22	57.3	Head	7.9645	1.1934	0.4056	0.7709	0.7542	0.5199
			L. Jamb	7.9056	1.1824	0.4077			
			R. Jamb	7.9056	1.1824	0.4077			
			Sill	8.2770	1.1331	0.4092			
15	0.20	58.4	Head	7.9645	1.1934	0.3927	0.7631	0.7460	0.5070
			L. Jamb	7.9056	1.1824	0.3948			
			R. Jamb	7.9056	1.1824	0.3948			
			Sill	8.2770	1.1331	0.3963			

Detailed drawings, datasheets, representative samples of test specimens, a copy of this report, or other pertinent project documentation will be retained by Architectural Testing, Inc. for a period of four years from the original test date. At the end of this retention period such materials shall be discarded without notice and the service life of this report by Architectural Testing will expire. Results obtained are simulated values and were secured by using the designated test methods. This report does not constitute certification of this product nor an opinion or endorsement by this laboratory. It is the exclusive property of the client named herein and relates only to the specimen(s) simulated. This report may not be reproduced, except in full, without the written approval of Architectural Testing, Inc.

For ARCHITECTURAL TESTING, INC.:

SIMULATED BY:

REVIEWED BY:

---

Eric Barilar  
Simulation Technician

---

Kevin S. Louder  
Project Engineer

EAB:EAB  
B3772.20-116-45

Attachments (pages): This report is complete only when all attachments listed are included.

Appendix A: Drawings and Bills of Material (23)

### Revision Log

<u>Rev. #</u>	<u>Date</u>	<u>Page(s)</u>	<u>Revision(s)</u>
.01R0	10/27/2011	All	Original Report Issue

All drawings and Bills of Material used in simulating this product are enclosed in this Appendix.

# STANDARD SINGLE DOOR BOM -1.75 Frame

<b>ATI</b>	
<b>Report #</b>	<u>B3772-116-45</u>
<b>Date</b>	<u>10/20/2011</u>
<b>Simulator</b>	<u><i>Eric Barilko</i></u>

## FRAME:

Description	QTY	Length	Part number	Material
4500 Jamb 1.3/4" x 4 1/2"	2	82 3/8"	E4544	
Header 1 3/4" x 4 1/2"	1	34 1/4"	E45124	
	1	34 7/23"		
Header Door stops & Jambs	2	80 5/8"	E4531	
Weather pile	30 ft		P1098A	
closure open back plate	2		E4543	

## DOOR:

Description	QTY	Length	Narrow P/N	Medium P/N	Wide P/N	Material
Beveled Door Stiles	2	79 13/16"	E0055- 2 1/8"	E0086- 4"	E0416 - 5"	
Door Top Rail	1	29 13/16"	E0255- 2 1/8"	E0054- 4"	E0318 - 5"	
Top Rail Lug	2		P168	P031	P339	AL
Door Botom Rail	1	29 13/16"	E0054- 4"	E0419- 6 1/2"	E0419- 6 1/2"	
Bottom Rail Lug	2		P031	P341	P341	AL
Top Rail & Bottom Rail Tie Rods	2	33 1/4"	P020B	P020	P020	Steel
Washer for Tie Rods	4		P852	P853	P853	steel/AL
Hex nuts for Tie rods	4		S071A	S071A	S071A	Steel
Exterior Glass Stop 1" glass	4		E0927	E0927	E0927	
Interior Glass Stop 1" glass	4		E0928	E0928	E0928	
Gasket	35.42		P0017	P0017	P0017	
Adjutable Wedge Setting Bck	2		P1911	P1911	P1911	Polypropylene
Self Adhesive Setting Bck	3		P1912	P1912	P1912	EPDM
Threshold	1		E0019	E0019	E0019	
Threshold clip	2		P679	P679	P679	AL

## MATERIAL:

E - All E part numbers are AL extrusions

# Standard Doors - Single 1.75" Jamb detail Elevations & 1/4 Size Details

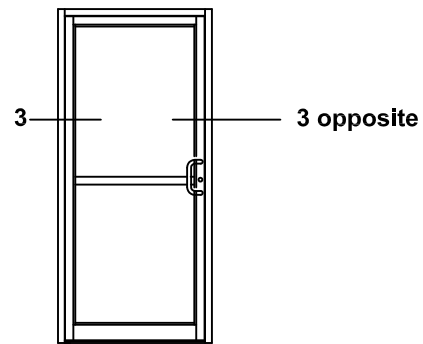

	<b>ATI</b>
Report #	<u>B3772-116-45</u>
Date	<u>10/20/2011</u>
Simulator	<u><i>Eric Borillo</i></u>

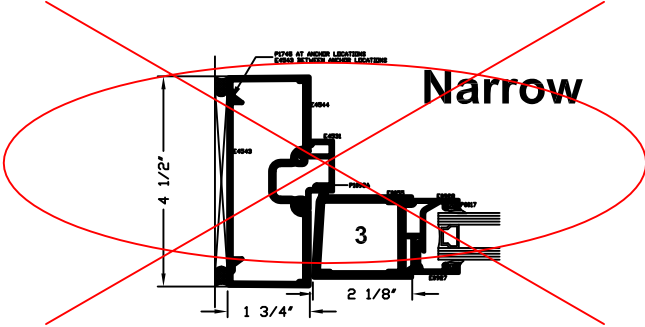
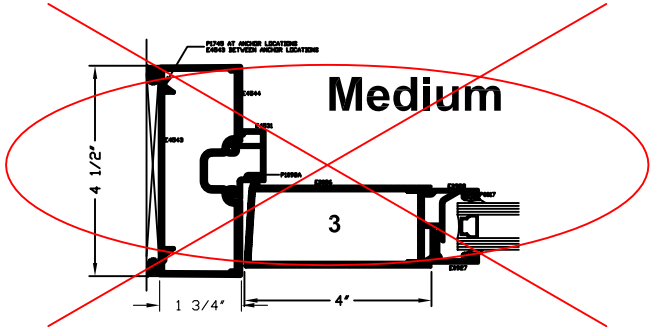
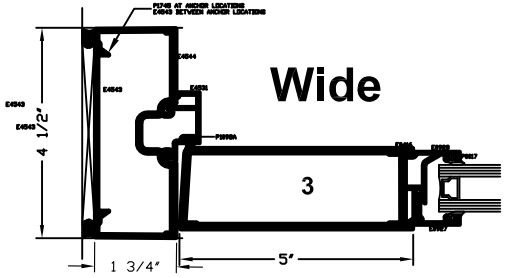

\*SEALANT, ROD, & ANCHORS NOT BY TUBELITE

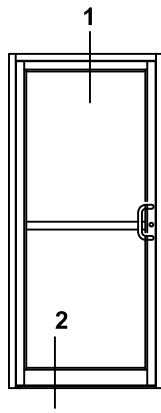

# Standard Doors - Single 1.75 frame Elevations & 1/4 Size Details

<b>ATI</b>	
<b>Report #</b>	<u>B3772-116-45</u>
<b>Date</b>	<u>10/20/2011</u>
<b>Simulator</b>	<u><i>Eric Barilko</i></u>

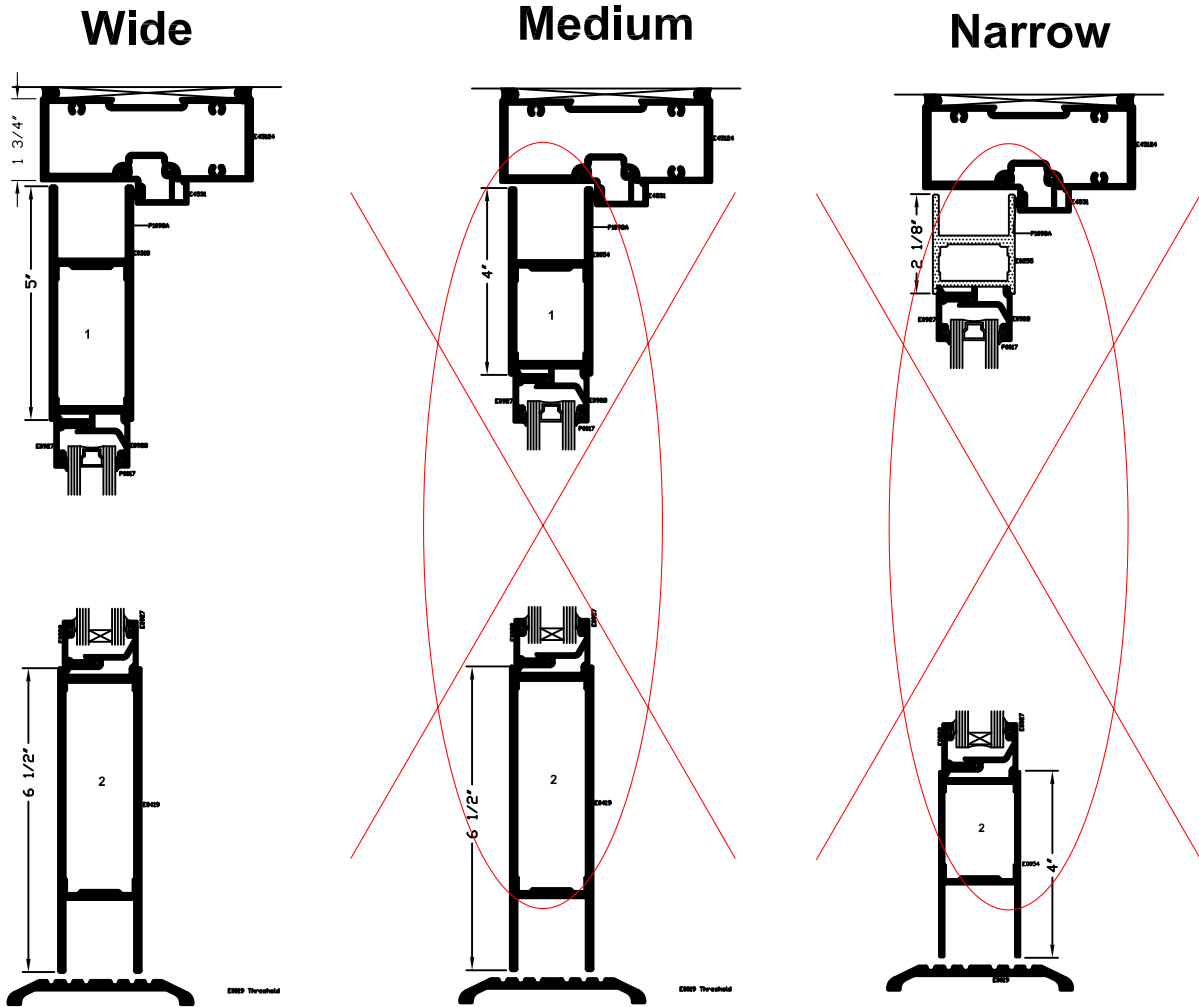

\*SEALANT, ROD, & ANCHORS NOT BY TUBELITE



**ATI**  
**Report #** B3772-116-45  
**Date** 10/20/2011  
**Simulator** Eric Barthe

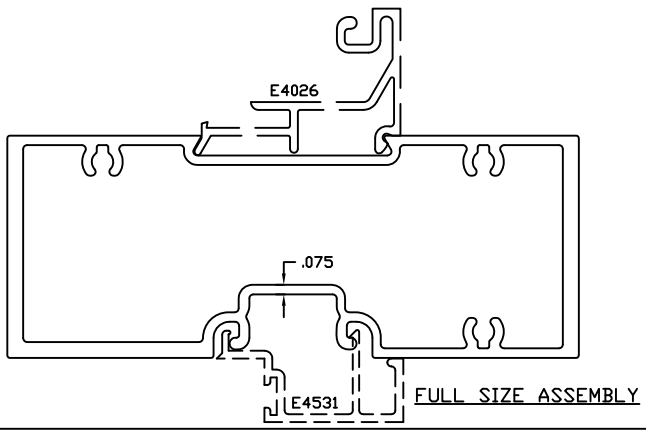
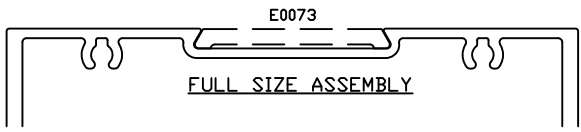
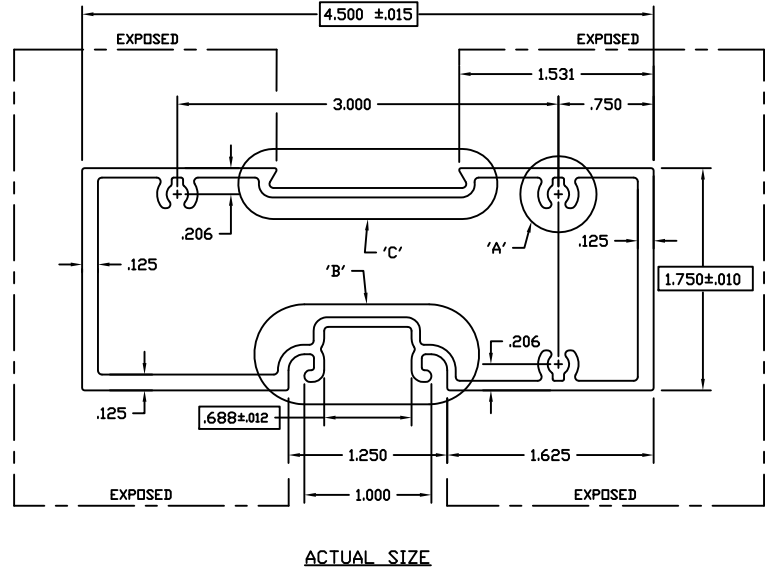
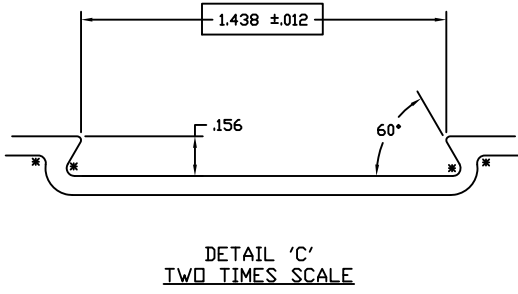
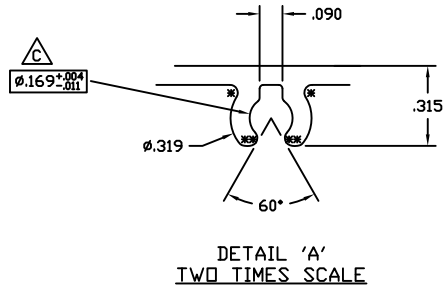
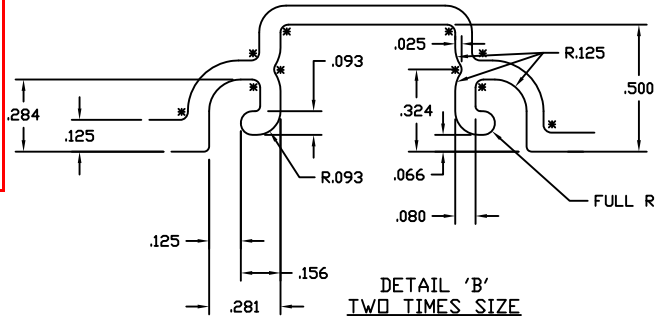

INDICATES CRITICAL DIMENSION

©2006 TUBELITE INC. ALL RIGHTS RESERVED  
 ALUMINUM ASSOCIATION STANDARD TOLERANCES APPLY UNLESS NOTED  
 ALL UNSPECIFIED RADII .015  
 \* INDICATES .031 RADIUS  
 □ DENOTES CRITICAL DIMENSION  
 ALL DIES PROPERTY OF TUBELITE

**TUBELITE**  
 Dependable  
 LEADING IN ECO-FRIENDLY OPERATIONAL CURTAINWALL AND ENTRANCE SYSTEMS

3056 WALKER RIDGE NW, SUITE G  
 WALKER, MICHIGAN 49544

WALL THK	.075	SECTION CLASS	H	MAT'L	6063-T5	RATIO	40:1
PERIMETER (OUT TOTAL)	14.791(29.991)	AREA	1.392	WGT/FT	1.637		
FACTOR	19	CIRCLE SIZE	4.828	INT'L VOLUME	N/A		
RXX	1.589	SXX	1.539	IXX	3.516	CXX	2.285
RYY	.678	SYY	.701	IYY	.639	CYY	.913

DOOR HEADER 1 3/4" X 4 1/2"  
 E4500 STOREFRONT

DRAWN BY	SRD	DRWG DATE	12/08/02	APP'D BY		DATE APP'D	
DWG SCALE	NOTED	PRODUCT CODE	160		E45124		C

REV	DATE	DESCRIPTION	INTL
EDI729	5-17-93	RELEASE TO TOOLING	KMH
EDI764	7-7-93	REVISE EXTR. # WAS E-45007	KMH
EDI772	7-28-93	RELEASE TO PRODUCTION	KMH
A	11-8-95	REVISED SCREW BOSS	SRK
EDI231	11-8-95	RELEASE TO TOOLING	SRK
B	03/07/03	REVISED GL. POCKET AND REGLET - REDUCED WEIGHT	SRD
	03/07/03	RENAMED ES12C15 - RELEASE FOR PRODUCTION	SRD
C	09/15/10	.169 +.004/-011, WAS .162±.004	CRH

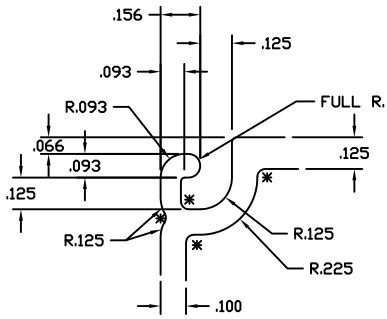

DETAIL 'A'  
TWO TIMES SIZE

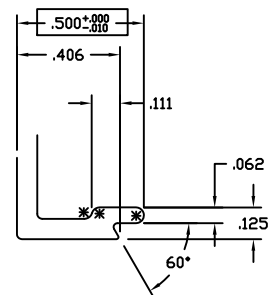

DETAIL 'B'  
TWO TIMES SIZE

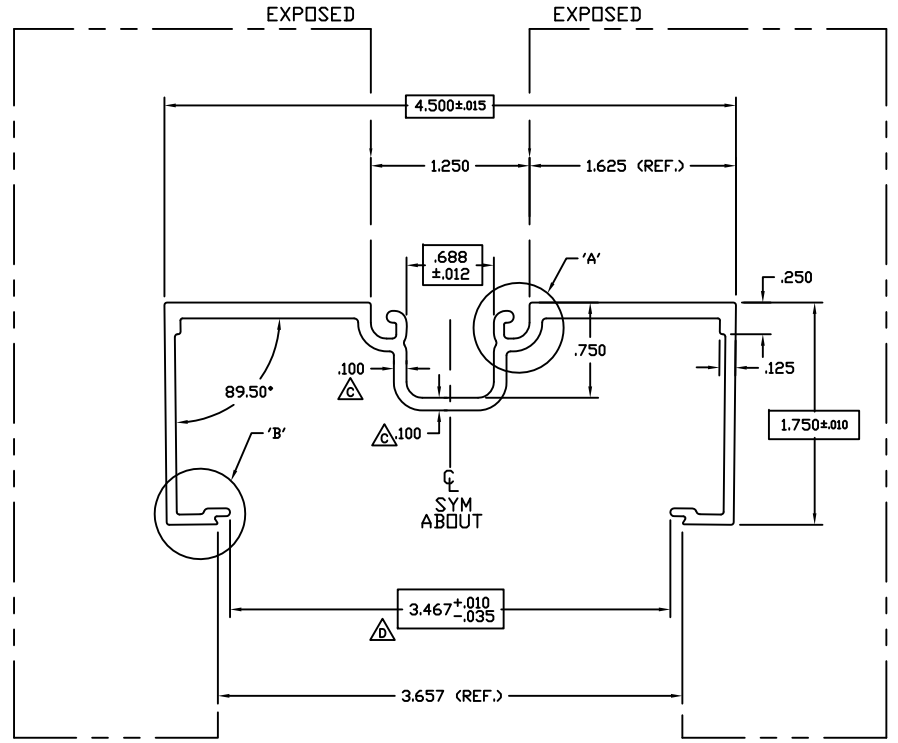

FULL SIZE

INDICATES CRITICAL DIMENSION

**ATI**

Report # B3772-116-45

Date 10/20/2011

Simulator Eric Barilla

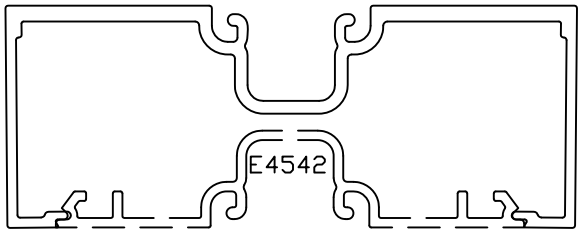

ASSEMBLY

© 2006 TUBELITE INC. ALL RIGHTS RESERVED  
ALUMINUM ASSOCIATION STANDARD TOLERANCES APPLY UNLESS NOTED

**TUBELITE**  
LEADING IN HIGH-IMPACT OPERATING CURTAINWALL AND ENTRANCE SYSTEMS

3056 WALKER RIDGE NW, SUITE G  
WALKER, MICHIGAN 49544

WALL THK.	.080	SECTION CLASS	S	MAT'L	6063-T5	RATIO	53:1
PERIMETER OUT (TOTAL)	20.704	AREA	1.030	WGT/FT	1.211		
FACTOR	17	CIRCLE SIZE	4.802	INFTLL VOLUME	N/A		
RXX	1.577	SXX	1.139	IXX	2.562	CXX	2.250
RYY	.543	SYY	.245	IYY	.304	CYY	1.241

DENOTES CRITICAL DIMENSION  
 ALL DIES PROPERTY OF TUBELITE

REV	DATE	DESCRIPTION	INTL
ED2933	6-26-97	REV. .125 WALL CONTINUOUS	SRK
A	03/07/03	REVISED GL. POCKET AND REGLET - REDUCED WEIGHT	SRD
	03/07/03	RENAMED E912C14 - RELEASE FOR PRODUCTION	SRD
B	03/17/04	REVISED WALL THICKNESS IN POCKET AREA AND LEGS	CRH
C	04/08/04	REVISED WALL THICKNESS IN POCKET AREA	CRH
D	03/28-07	REDUCED OPENING FOR BETTER FIT	NIK

OPEN BACK FRAME 1 3/4" X 4 1/2"  
E4500 STOREFRONT

DRAWN BY	SRD	DRWG DATE	12/08/02	APPV'D BY		DATE APPV'D	
BWG SCALE	NOTED	PRODUCT CODE	160	E4544			



E4531

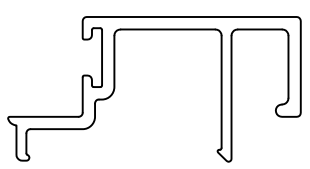
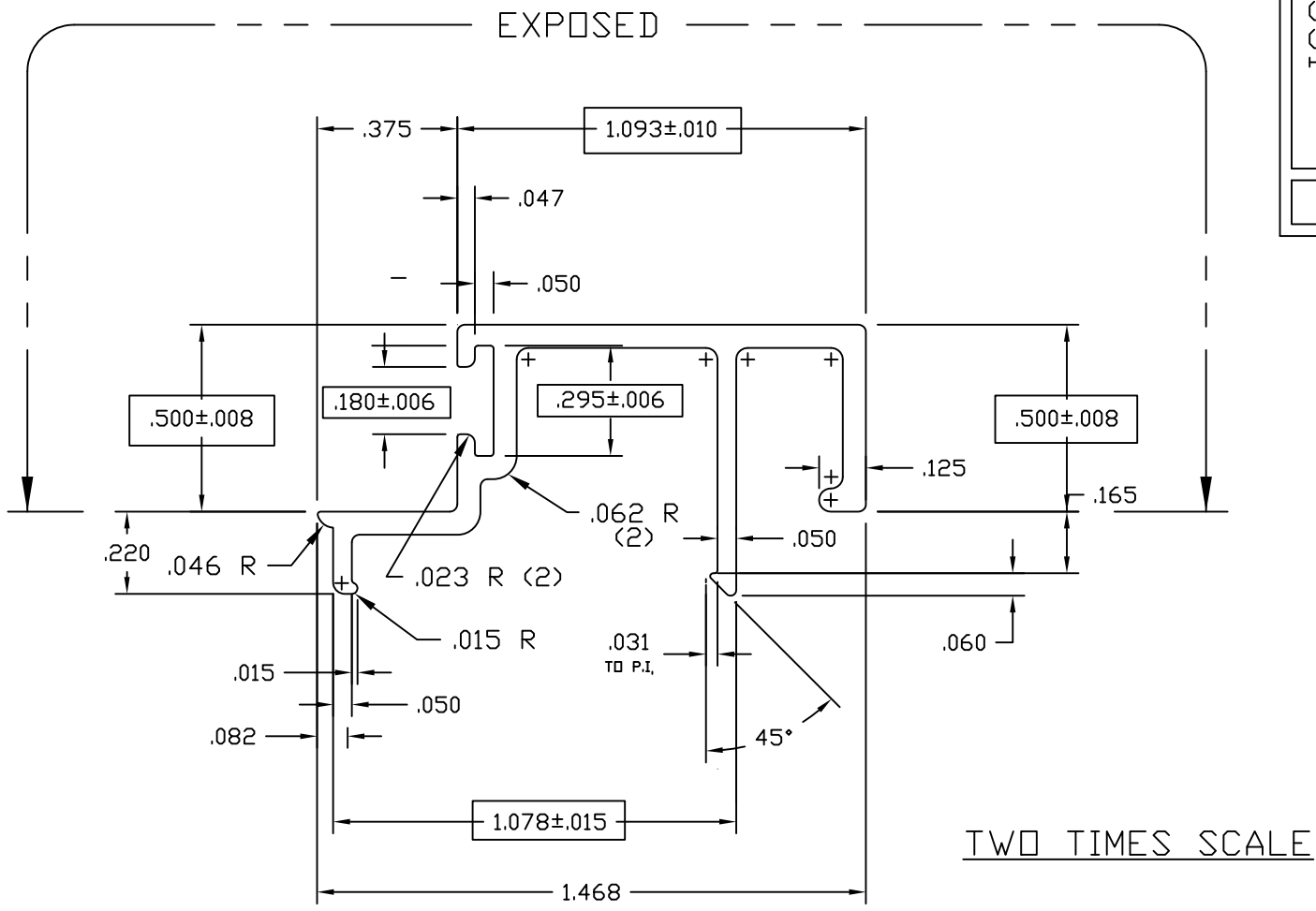

ACTUAL SIZE

**ATI**

Report # B3772-116-45

Date 10/20/2011

Simulator Eric Barilko

USED WITH 4500 SERIES  
REPLACES E-4510  
USE WITH P-1098A WEATHERING

© 2006 TUBELITE INC. ALL RIGHTS RESERVED  
ALUMINUM ASSOCIATION STANDARD  
TOLERANCES APPLY UNLESS NOTED  
ALL UNSPECIFIED RADII .015  
\* INDICATES .031 RADIUS

**TUBELITE®**  
DEPENDABLE  
LEADERS IN ECO-EFFICIENT STOREFRONT,  
CURTAINWALL AND ENTRANCE SYSTEMS

3056 WALKER RIDGE NW, SUITE G  
WALKER, MICHIGAN 49544

WALL THK.	.062	SECTION CLASS	S	MAT'L	6063-T5	RATIO	90
PERIMETER OUT (TOTAL)	6.966	AREA	.203	WGT/FT	.238		
FACTOR	29	CIRCLE SIZE	1.58	INFILL VOLUME	N/A		

RXX	.446	SXX	.049	IXX	.040	CXX	.824
RYY	.218	SYY	.021	IYY	.010	CYY	.461

DOOR STOP 1/2" X 1 3/32"  
E4500 STOREFRONT

DRAWN BY	LS	DRWG DATE	02/07/85	APPV'D BY		DATE APPV'D	
DWG SCALE	NOTED	PRODUCT CODE	160	E4531		REV	

REV	DATE	DESCRIPTION	INTL
	3/28/94	UPDATED SECTION PROPERTIES	TPB
	4/12/99	UPDATED EXPOSED	JEK

☐ DENOTES CRITICAL DIMENSION  
ALL DIES PROPERTY OF TUBELITE

**ATI**  
**Report #** B3772-116-45  
**Date** 10/20/2011  
**Simulator** Eric Bakula

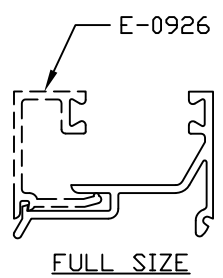
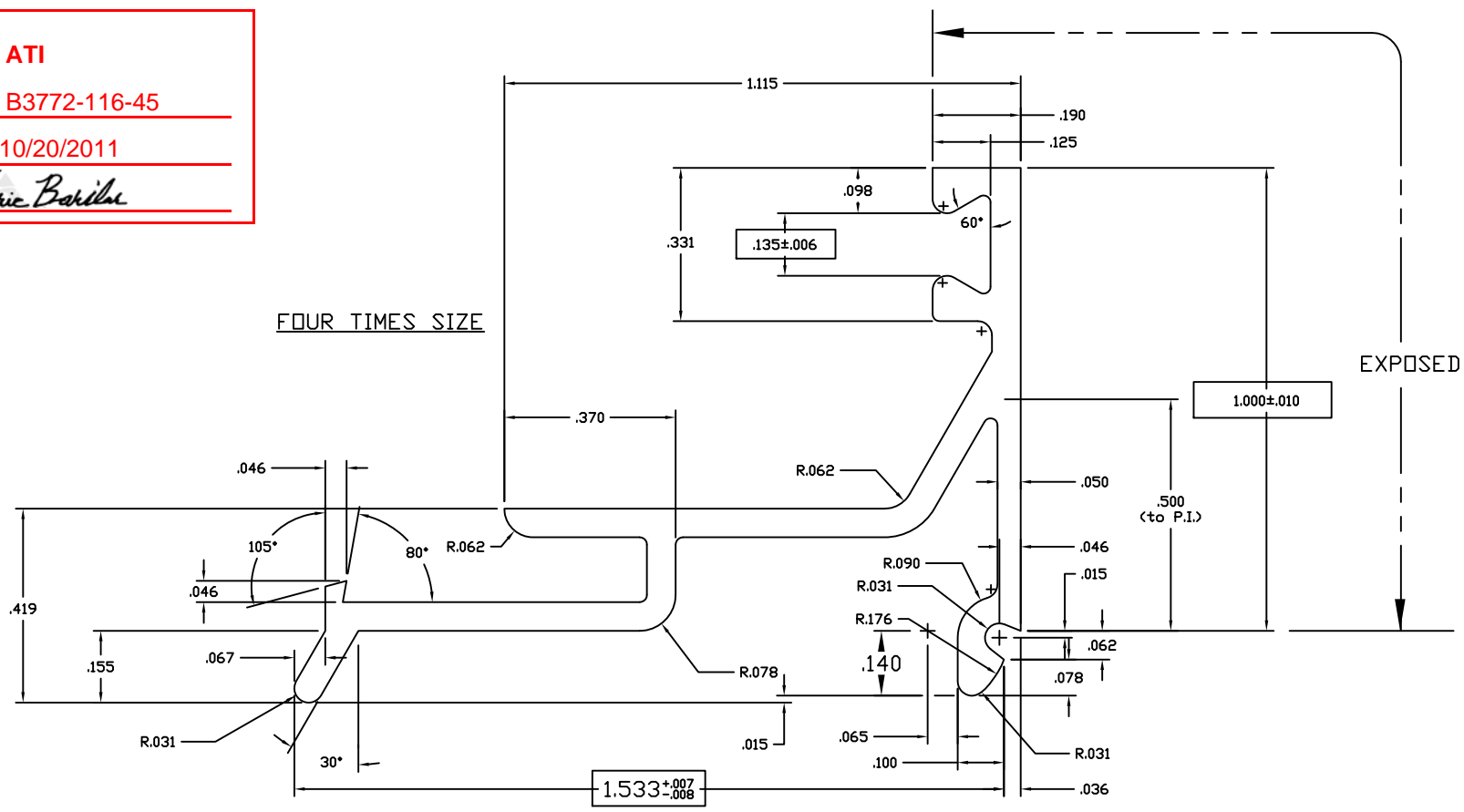

**NOTES:**

- 1) USE E-0927/0928 FOR 1" MAT'L
- 2) USE E-0926/0928 FOR 5/8" MAT'L
- 3) USE GLAZING BEAD P-302 FOR BOTH SIDES OF GLASS OR PANEL

©2006 TUBELITE INC. ALL RIGHTS RESERVED  
 ALUMINUM ASSOCIATION STANDARD  
 TOLERANCES APPLY UNLESS NOTED

**TUBELITE**  
 LEADING IN ECO-FRIENDLY OPERATING  
 CURTAINWALL AND ENTRANCE SYSTEMS

3056 WALKER RIDGE NW, SUITE G  
 WALKER, MICHIGAN 49544

WALL THK	.062	SECTION CLASS	S	MAT'L	6063-T5	RATIO	59:1
PERIMETER OUT (TOTAL)	7.540	AREA	.234	WGT/FT	.275		
FACTOR	27	CIRCLE SIZE	1.938	INFILL VOLUME	N/A		
RXX	.302	SXX	.030	IXX	.021	CXX	.701
RYY	.501	SYY	.113	IYY	.059	CYY	1.049

DENOTES CRITICAL DIMENSION  
 ALL DIES PROPERTY OF TUBELITE

REV	DATE	DESCRIPTION	INTL
	10/12/07	REMOVED LEG	RW

GLASS STOP, 1" HIGH FOR 1" GLASS STOCK DOORS

DRAWN BY	DWG DATE	07/03/84	APPV'D BY	DATE APPV'D
DWG SCALE	NOTED	PRODUCT CODE	100	E0928

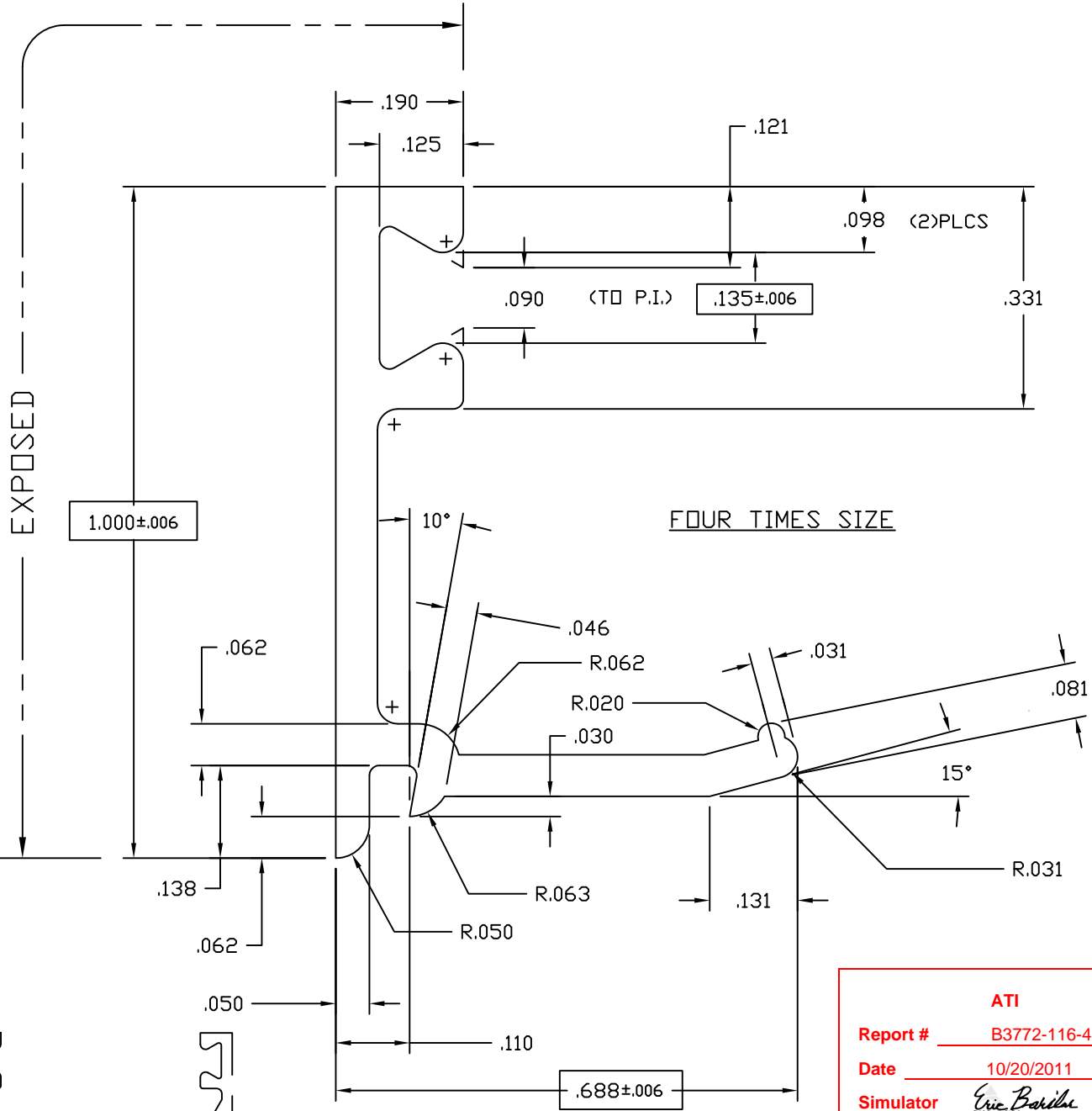

**ATI**

Report # B3772-116-45

Date 10/20/2011

Simulator Eric Barthe

- NOTES:
- 1) USE WITH 1" INSULATED GLASS OR 1" PANEL
  - 2) USE GLAZING BEAD P-302 BOTH SIDES
  - 3) USE WITH E-0928 OR E-0929

© 2006 TUBELITE INC. ALL RIGHTS RESERVED  
 ALUMINUM ASSOCIATION STANDARD TOLERANCES APPLY UNLESS NOTED  
 ALL UNSPECIFIED RADII .015  
 \* INDICATES .031 RADIUS

**TUBELITE**  
 LEADERS IN ECO-EFFICIENT STOREFRONT, CURTAINWALL AND ENTRANCE SYSTEMS

3056 WALKER RIDGE NW, SUITE G  
 WALKER, MICHIGAN 49544

WALL THK.	.062	SECTION CLASS	S	MAT'L	6063-T5	RATIO	74:1
PERIMETER OUT (TOTAL)	4.001	AREA	.124	WGT/FT	.146		
FACTOR	27	CIRCLE SIZE	1.120	INFILL VOLUME	N/A		

RXX	.321	SXX	.023	IXX	.013	CXX	.321
RYY	.185	SYY	.008	IYY	.004	CYY	.185

GLASS STOP, 1" HIGH FOR 1" GLASS STOCK DOORS

DRAWN BY	CRH	DRWG DATE	04/21/99	APPV'D BY		DATE APPV'D	
DWG SCALE	NOTED	PRODUCT CODE	100	E0927		REV	

REV	DATE	DESCRIPTION	INTL
X	xx/xx/xx	XXXXXXXXXXXXXXXX	XXX

☐ DENOTES CRITICAL DIMENSION  
 ALL DIES PROPERTY OF TUBELITE

E0419  
B

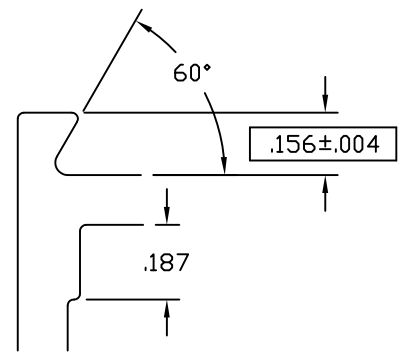
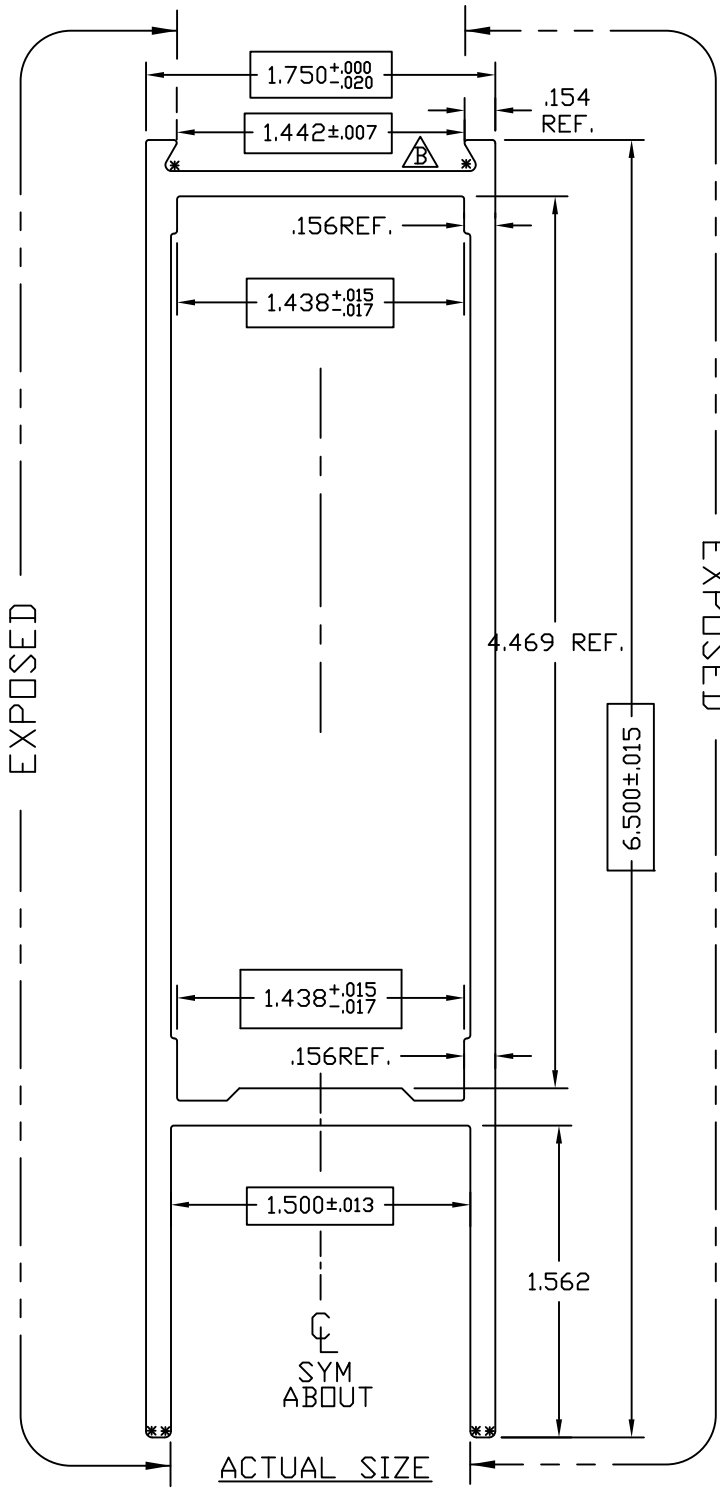

TWO TIMES SCALE  
**ATI**  
 Report # B3772-116-45  
 Date 10/20/2011  
 Simulator Eric Barilko

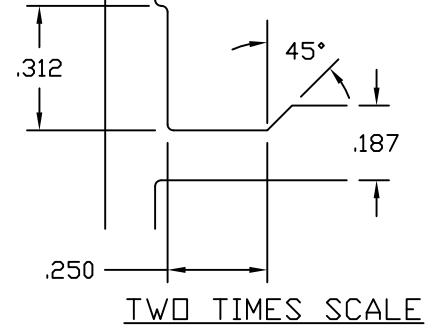

$.125^{+0.003}_{-0.011}$  TYP WALL UNLESS NOTED  
 SNAP FIT W/E-0437

© 2006 TUBELITE INC. ALL RIGHTS RESERVED  
 ALUMINUM ASSOCIATION STANDARD  
 TOLERANCES APPLY UNLESS NOTED  
 ALL UNSPECIFIED RADII .015  
 \* INDICATES .031 RADIUS

**TUBELITE**  
 LEADERS IN ECO-EFFICIENT STOREFRONT,  
 CURTAINWALL AND ENTRANCE SYSTEMS

3056 WALKER RIDGE NW, SUITE G  
 WALKER, MICHIGAN 49544

WALL THK.	NOTED	SECTION CLASS	H	MAT'L	6063-T5	RATIO	26:1
PERIMETER OUT (TOTAL)	19.959(26.440)	AREA	2.084	WGT/FT	2.451		
FACTOR	11	CIRCLE SIZE	6.720	INFILL VOLUME	N/A		

RXX	.747	SXX	1.330	IXX	1.164	CXX	.875
RYY	1.980	SYX	2.447	IYY	8.175	CYY	3.340

HORIZONTAL RAIL 6 1/2" X 1 3/4"  
 CUSTOM DOORS/FRAMES

☐ DENOTES CRITICAL DIMENSION  
 ALL DIES PROPERTY OF TUBELITE

REV	DATE	DESCRIPTION	INTL
A	11/16/00	1.449 WAS 1.438	CRH
B	07/08/03	1.449 +/-0.007 WAS 1.449 +0.000/-0.010	CRH

DRAWN BY	DH	DRWG DATE	04/19/84	APPV'D BY	CRH	DATE	12/08/00
DWG SCALE	NOTED	PRODUCT CODE	110	E0419	REV	B	

E0416  
D

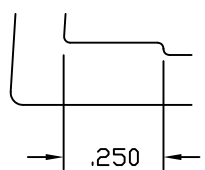

TWO TIMES SIZE

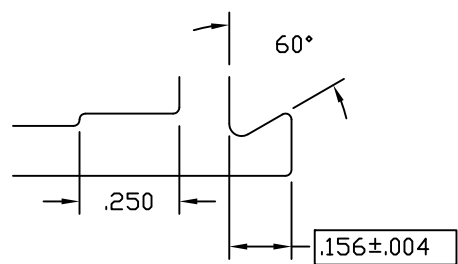

TWO TIMES SIZE

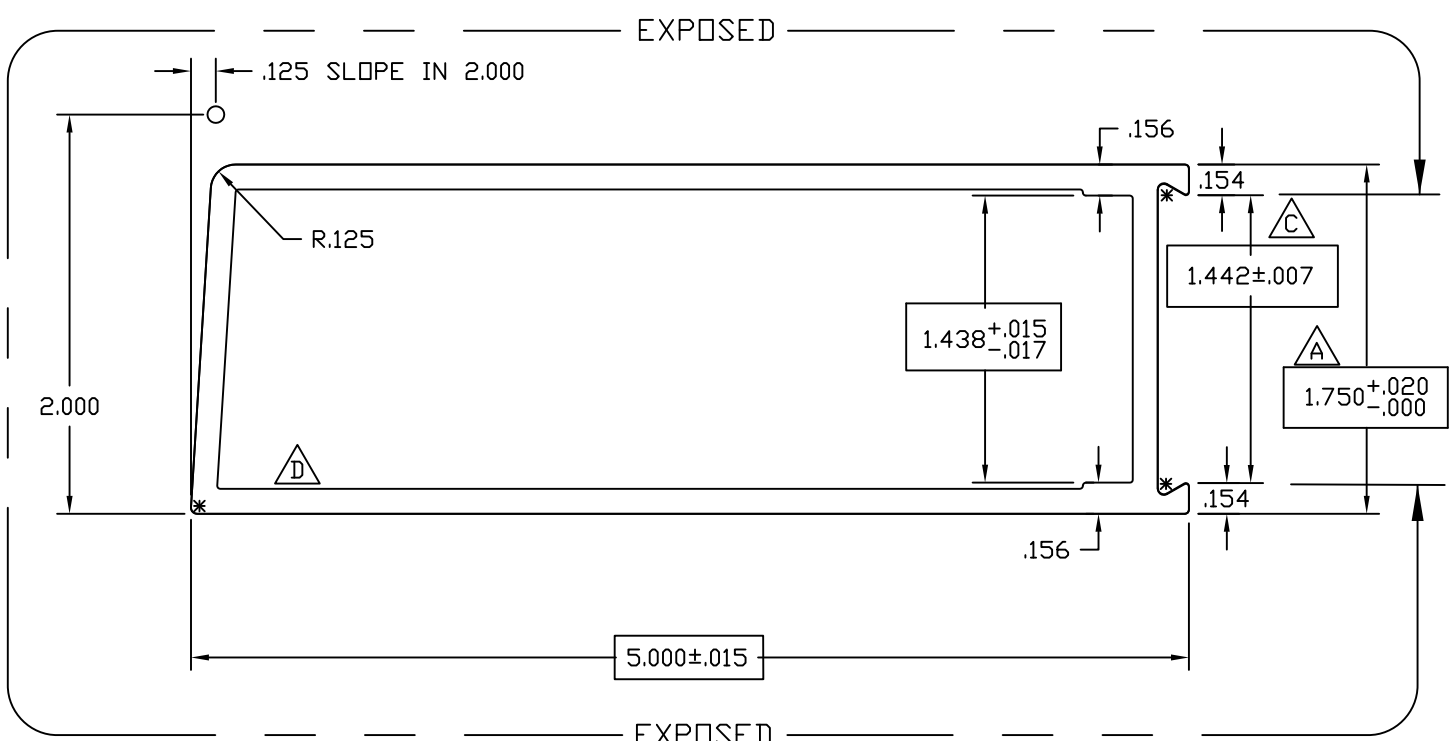

EXPOSED  
EXPOSED  
ACTUAL SIZE

**ATI**

**Report #** B3772-116-45

**Date** 10/20/2011

**Simulator** Eric Barilla

$.125 \begin{matrix} +.003 \\ -.011 \end{matrix}$  TYP WALL UNLESS NOTED

SNAP FIT W/E-0437

© 2006 TUBELITE INC. ALL RIGHTS RESERVED  
ALUMINUM ASSOCIATION STANDARD TOLERANCES APPLY UNLESS NOTED  
ALL UNSPECIFIED RADII .015  
\* INDICATES .031 RADIUS



3056 WALKER RIDGE NW, SUITE G  
WALKER, MICHIGAN 49544

WALL THK.	NOTED	SECTION CLASS	H	MAT'L	6063-T5	RATIO	34:1
PERIMETER OUT (TOTAL)	13.733	AREA	1.623	WGT/FT	1.909		
FACTOR	13	CIRCLE SIZE	5.293	INFILL VOLUME	N/A		

RXX	.742	SXX	1.012	IXX	.893	CXX	.883
RYX	1.686	SYX	1.823	IYX	4.611	CYX	2.529

BEVELED VERTICAL RAIL 1 3/4" X 5"  
CUSTOM DOORS/FRAMES

DRAWN BY	DH	DRWG DATE	04/08/84	APPV'D BY		DATE APPV'D	
DWG SCALE	NOTED	PRODUCT CODE	110	E0416		REV	D

REV	DATE	DESCRIPTION	INTL
A	1/21/92	+0.020/-0.000 WAS +/-0.010	KMH
B	04/10/01	1.449 +0.000/-0.010 WAS 1.438 +0.002/-0.013	CRH
C	10/15/02	1.442+/-0.007 WAS 1.449 +0.000/-0.010	CRH
D	12/08/10	RMV .030 step in innser lower left corner	TT

E0318  
B

ATI  
Report # B3772-116-45  
Date 10/20/2011  
Simulator Eric Barilla

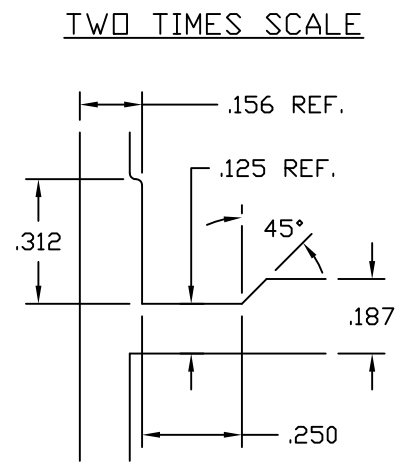
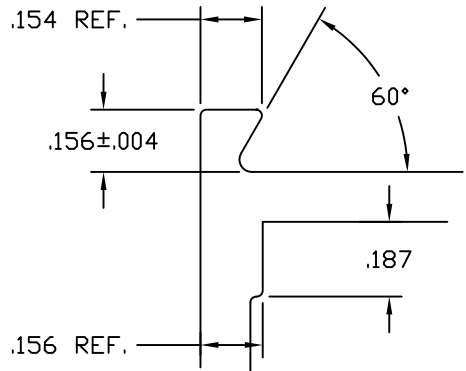
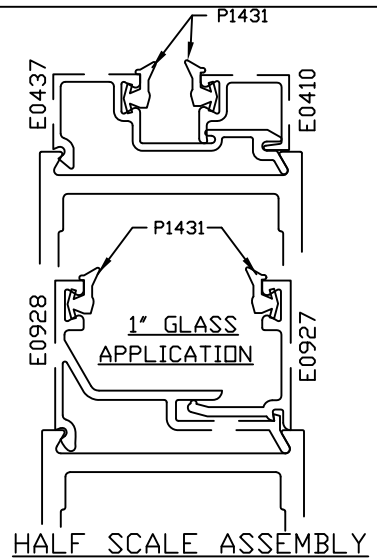
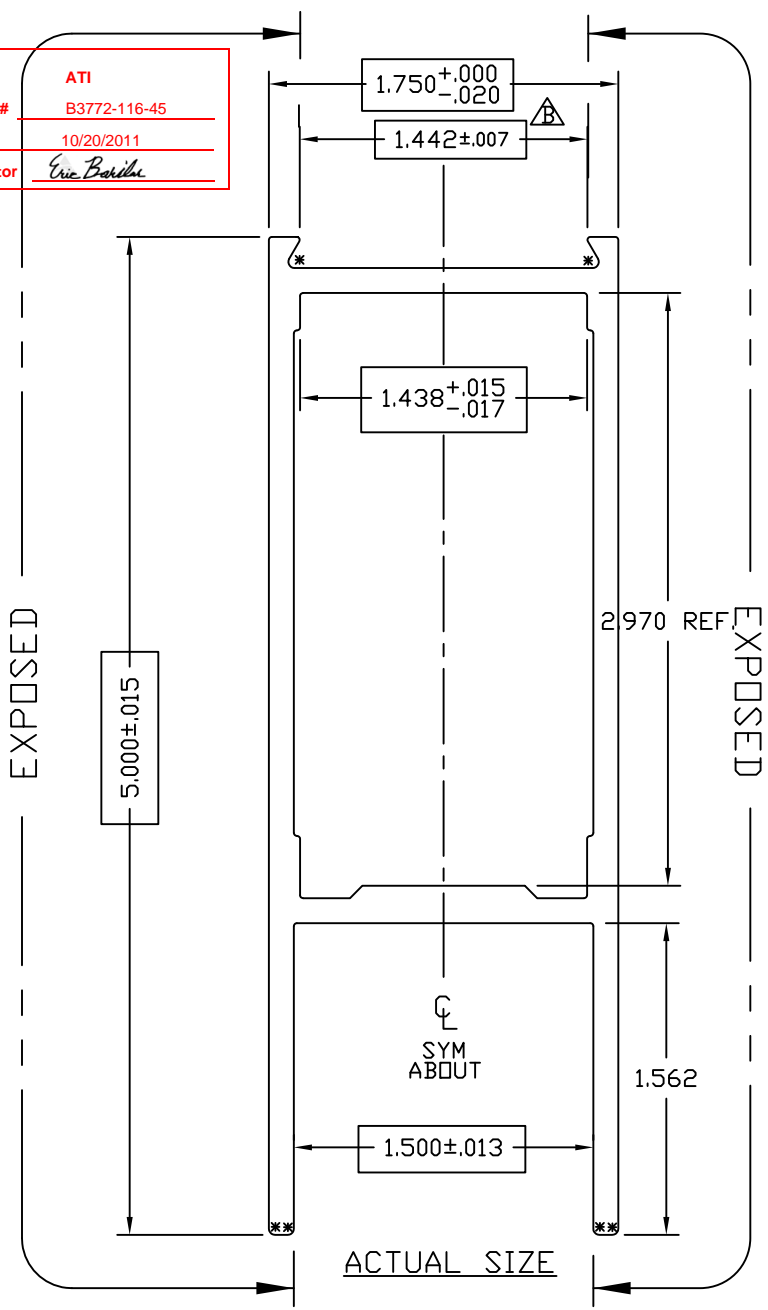

.125 +.003/-0.011 TYP WALL UNLESS NOTED  
SNAP FIT W/E0437(1/4"GLASS) AND E0928(1"GLASS)

© 2006 TUBELITE INC. ALL RIGHTS RESERVED  
ALUMINUM ASSOCIATION STANDARD TOLERANCES APPLY UNLESS NOTED  
ALL UNSPECIFIED RADII .015  
\* INDICATES .031 RADIUS  
□ DENOTES CRITICAL DIMENSION  
ALL DIES PROPERTY OF TUBELITE

**TUBELITE**  
DEPENDABLE  
LEADERS IN ECO-EFFICIENT STOREFRONT, CURTAINWALL AND ENTRANCE SYSTEMS

3056 WALKER RIDGE NW, SUITE G  
WALKER, MICHIGAN 49544

WALL THK.	NOTED	SECTION CLASS	H	MAT'L	6063-T5	RATIO	32:1
PERIMETER OUT (TOTAL)	16.983(26.047)		AREA	1.708	WGT/FT	2.008	
FACTOR	13	CIRCLE SIZE	5.282	INFILL VOLUME	N/A		

RXX	.732	SXX	1.046	IXX	.916	CXX	.875
RYY	1.486	SYX	1.432	IYY	3.773	CYY	2.365

HORIZONTAL RAIL 5" X 1 3/4"  
CUSTOM DOORS/FRAME

REV	DATE	DESCRIPTION	INTL
A	11/07/00	+0.00/-0.10 WAS ±0.02	CRH
B	04/10/02	±0.07 WAS +0.00/-0.10	CRH

DRAWN BY	DLH	DRWG DATE	04/26/84	APPV'D BY		DATE APPV'D	
DWG SCALE	NOTED	PRODUCT CODE	110	E0318		REV	B

**ATI**  
**Report #** B3772-116-45  
**Date** 10/20/2011  
**Simulator** Eric Borille

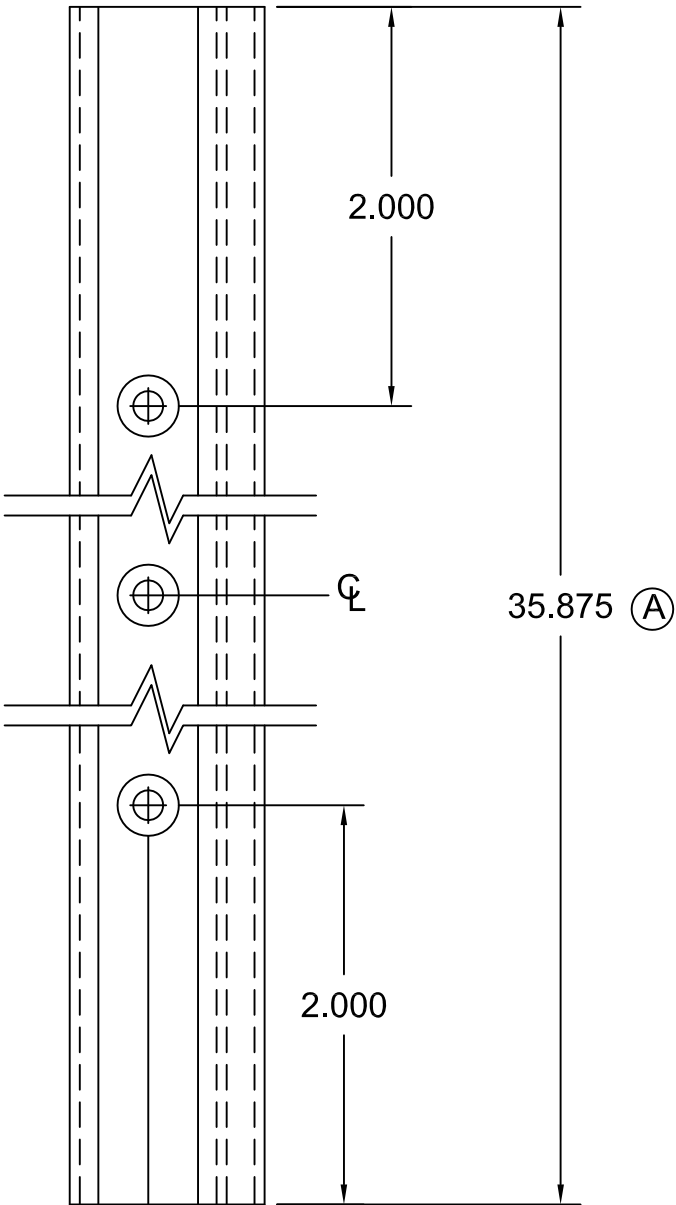

Operations:

1. Cut to length as required from E2059
2. Drill 3 holes with #25 Drl & Ctsk for S-064 (#6 FHCS)
3. Cut P-830 to length, Install, & Crimp ends
4. Cut P-914 to length, and install.
5. Paint ends as required
6. Ship with three (3) S064 Screws.

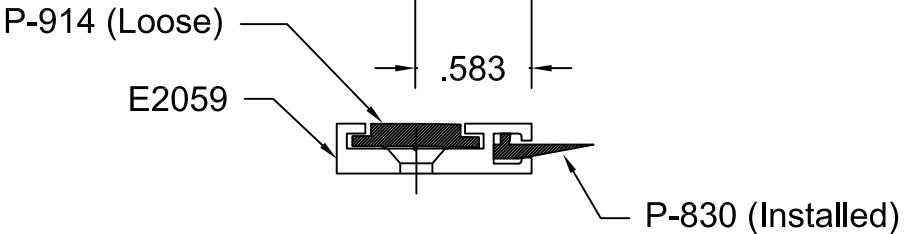

© 2006 TUBELITE INC. ALL RIGHTS RESERVED  
 ALL UNSPECIFIED RADII .015  
 \* INDICATES .031 RADIUS  
 □ DENOTES CRITICAL DIMENSION

**TUBELITE®**  
 DEPENDABLE  
 LEADERS IN ECO-EFFICIENT STOREFRONT,  
 CURTAINWALL AND ENTRANCE SYSTEMS

3056 WALKER RIDGE NW, SUITE G  
 WALKER, MICHIGAN 49544

REV	DATE	DESCRIPTION	INTL
	7/29/83	Released Part per ED 128	PJ
A	05/17/90	ED #1222 Dim was 34.875	KMH
B	8/24/01	Redrawn for CAD	DMT
C	06/19/03	OUTSOURCE - ADD S064 SCREWS	SRD

Door Seal to use with  
E2058 Threshold

DRAWN BY PJ	DRWG DATE 05/09/83	APPV,D BY	DATE APPV'D
DRWG SCALE Full	PRODUCT CODE 380	<b>P1275</b>	
			REV <b>C</b>

P1098A

B

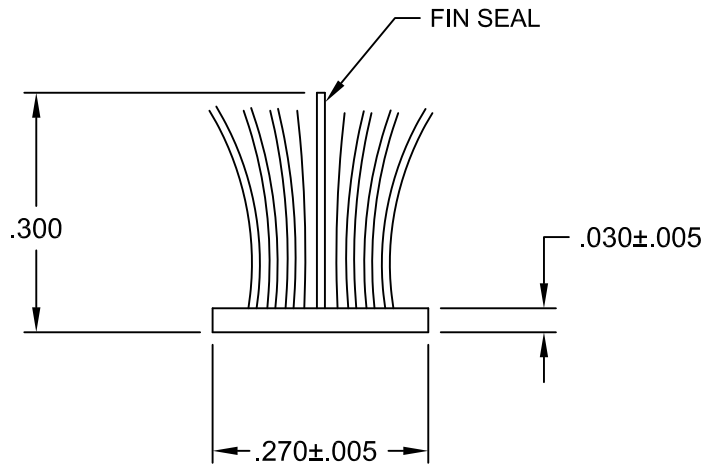

Actual Size

**ATI**

**Report #** B3772-116-45

**Date** 10/20/2011

**Simulator** Eric Barthelemy

© 2006 TUBELITE INC. ALL RIGHTS RESERVED

ALL UNSPECIFIED RADII .015

\* INDICATES .031 RADIUS

□ DENOTES CRITICAL DIMENSION

**TUBELITE®**  
 DEPENDABLE  
 LEADERS IN ECO-EFFICIENT STOREFRONT,  
 CURTAINWALL AND ENTRANCE SYSTEMS

3056 WALKER RIDGE NW, SUITE G  
WALKER, MICHIGAN 49544

REV	DATE	DESCRIPTION	INTL
A	03/08/83	Release Part per ED 109	
B	05/29/02	Redrawn for CAD	DMT

<b>Poly Bond Fin-Seal Weathering</b> use with Door Stop E1377			
DRAWN BY	Don H	DRWG DATE	06/03/83
APPV'D BY		DATE APPV'D	
DRWG SCALE	Noted	PRODUCT CODE	380
<b>P1098A</b>			<b>B</b>

ATI

Report # B3772-116-45

Date 10/20/2011

Simulator Eric Basile

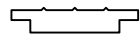

ACTUAL SIZE

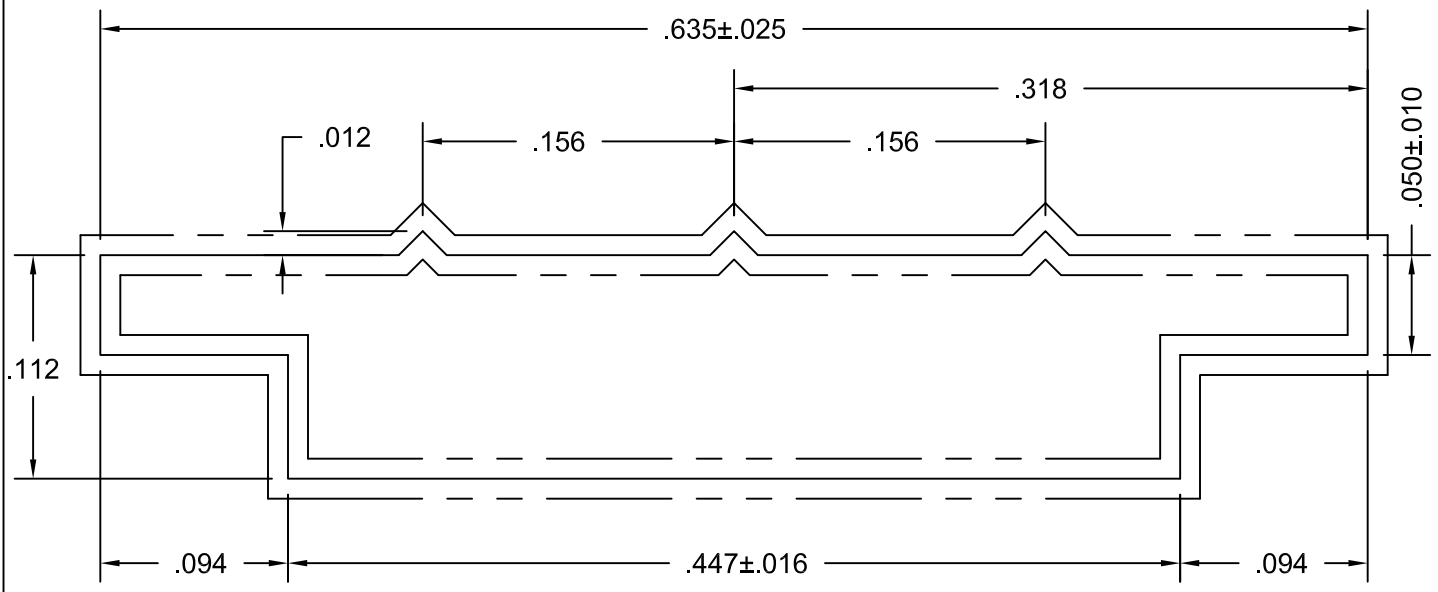

Ten Times Size

NOTE: Part to receive Silicone Bath after Extruding

Purchased Part  
Avon Rubber  
90 Durometer  
250' Rolls

© 2006 TUBELITE INC. ALL RIGHTS RESERVED  
ALL UNSPECIFIED RADII .015  
\* INDICATES .031 RADIUS  
□ DENOTES CRITICAL DIMENSION



3056 WALKER RIDGE NW, SUITE G  
WALKER, MICHIGAN 49544

REV	DATE	DESCRIPTION	INTL
A	01/19/96	Redrawn for AutoCAD	DMT

<p>EPDM Rubber Glazing Use with M1061, M1063, M1202</p>			
DRAWN BY	KMH	DRWG DATE	01/19/96
APPV,D BY		DATE APPV'D	
DRWG SCALE	Noted	PRODUCT CODE	380
<p>P914</p>			<p>REV A</p>

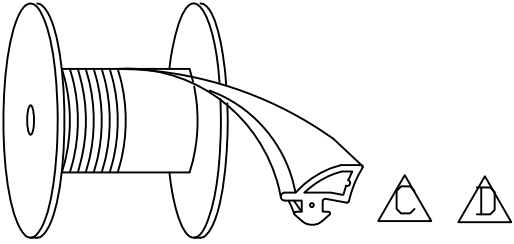

**ATI**

Report # B3772-116-45

Date 10/20/2011

Simulator Eric Barilko

Material must UNREEL like this...

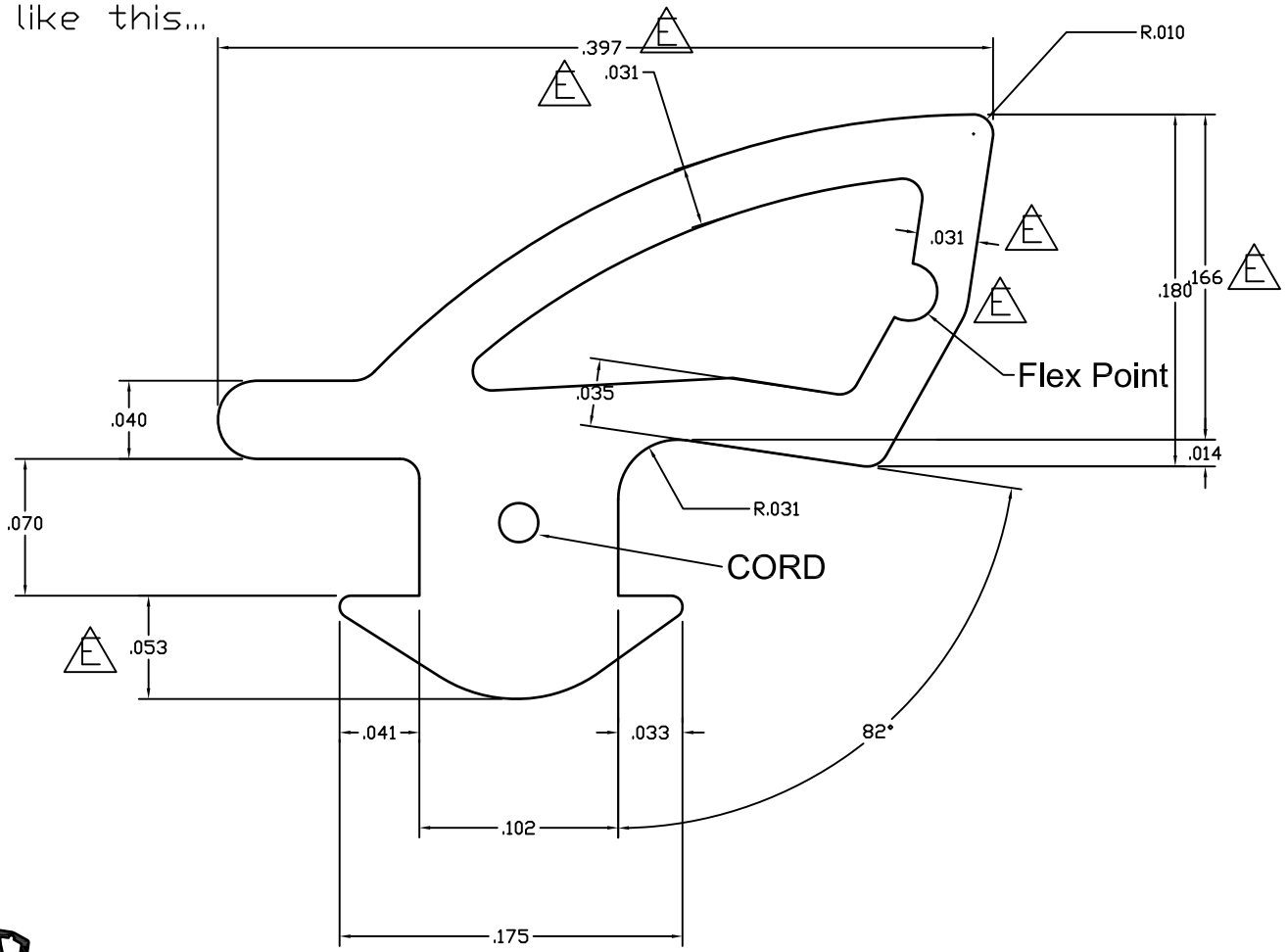

ACTUAL SIZE

MATERIAL: EPDM 60 DUROMETER WITH CORD

© 2006 TUBELITE INC. ALL RIGHTS RESERVED  
 ALL UNSPECIFIED RADII .015  
 \* INDICATES .031 RADIUS  
 □ DENOTES CRITICAL DIMENSION

**TUBELITE®**  
 DEPENDABLE  
 LEADERS IN ECO-EFFICIENT STOREFRONT,  
 CURTAINWALL AND ENTRANCE SYSTEMS

3056 WALKER RIDGE NW, SUITE G  
 WALKER, MICHIGAN 49544

REV	DATE	DESCRIPTION	INTL
A	08/20/07	MODIFIED DART: .070 WAS .060 AND .051 WAS .061 ADDED CORD	NIK
B	10/16/08	ADDED MANUFACTURER'S TOLERANCES FOR REFERENCE	SRD
C	10/22/10	Modified gasket position of how the reel should roll	TT
D	12/16/10	Modified gasket position of how the reel should roll	TT
E	02/15/11	Rev flex pt, thickness was .032, .180 was .188	TT

1/4"-1" DOOR GLAZING GASKET  
 500' ROLLS

DRAWN BY NIK	DRWG DATE 4-17-07	APPV.D BY	DATE APPV'D	REV
DRWG SCALE 10X	PRODUCT CODE 100	P0017		E

ATI

Report # B3772-116-45

Date 10/20/2011

Simulator Eric Barilko

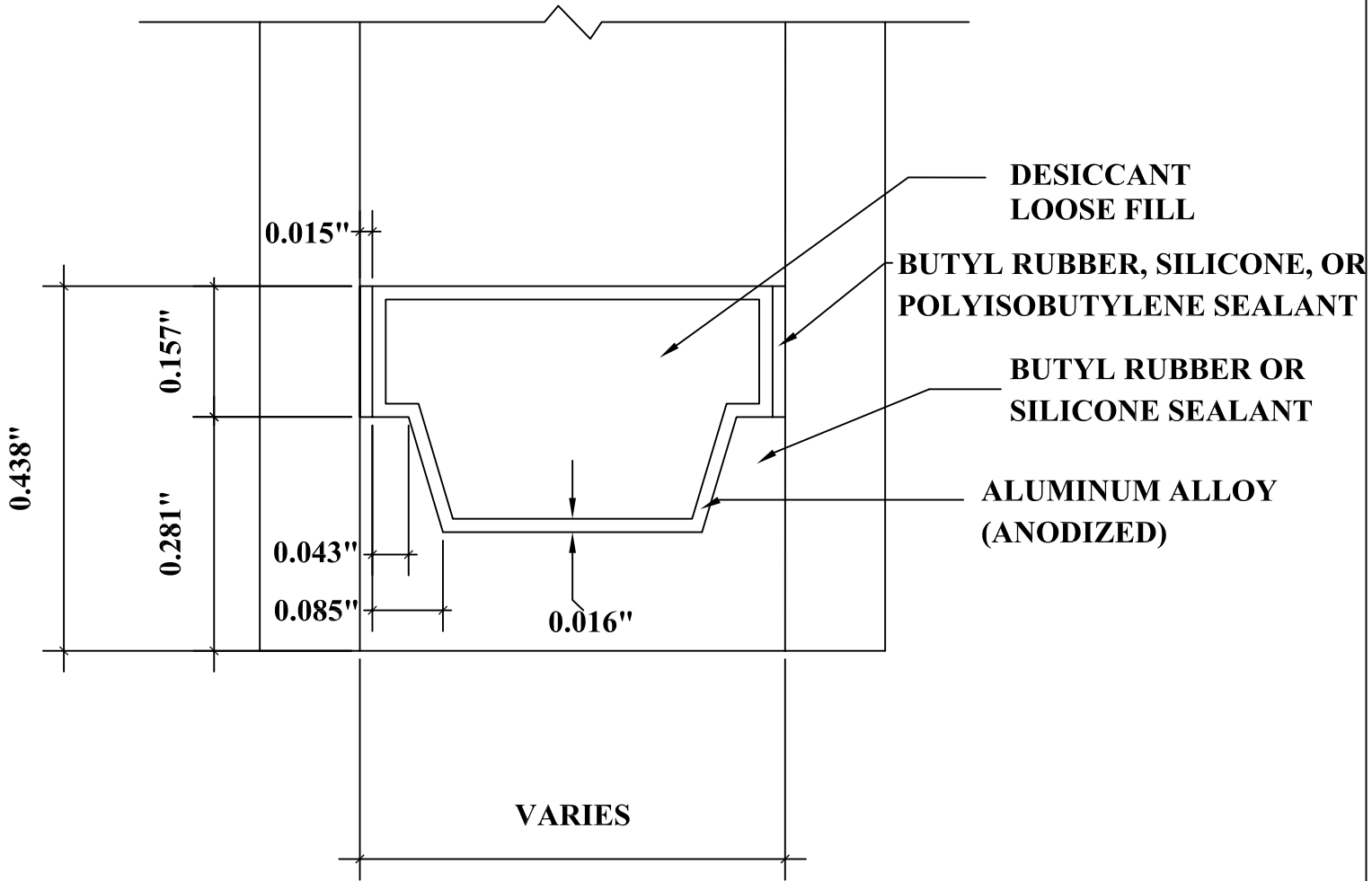

DETAIL FOR THERMAL MODELING OF  
ALUMINUM SPACER (A1-D)