

MID AMERICA TESTING LABORATORY, INC.

10525 SIGNAL HILL DRIVE • CATAWISSA, MISSOURI 63015

(636) 257-4722 • FAX (636) 257-5425

MANUFACTURER: Tubelite, Inc.
4878 Mackinaw Trail
Reed City, MI 49677

SYSTEM: Zero Sight-Line Curtain Wall & Storefront Vent

SERIES NUMBER: CVW – 3700

PERFORMANCE CLASS: AP-AW-70 61 1/2" wide X 37 3/4" tall

JOB NUMBER: 01108IP

DATE OF REPORT: December 17, 2001

LOCATION OF TESTING: Winco Window Company

DATE OF TESTING: December 12, 2001

EXPERATION DATE: December 12, 2005

All tests were conducted in accordance with procedures outlined in AAMA/NWWDA 101/I.S.2-97 and applicable ASTM standards.

The following were present for all or portions of the laboratory testing.

Mr. Jack Hornsey	Winco Window Company
Mr. Bob Fortin	Tubelite, Inc.
Mr. Craig DeDayos	Tubelite, Inc.
Mr. Jack Hartman	Tubelite, Inc.
Mr. Travis Swisshelm	Mid America Testing Laboratory
Mr. Craig George	Mid America Testing Laboratory

UNIT DESCRIPTION

Winco personnel for purposes of weatherization and structural testing installed the Series Zero-Sight Line project out vent manufactured by Tubelite in a test chamber. The overall frame had a dimension of 61 1/2" wide X 37 3/4" tall. The sash measured 60" wide X 36" tall.

The unit was glazed with a nominal 1/4" X 1/2" X 1/4" insulated glass. The glazing consisted of 1/2" Tremco tape with structurally glazed silicone in interior. The exterior consisted of a bead of silicone between glass and frame around perimeter of sash.

The sash was weathered with a bulb gasket around interior and exterior perimeter of sash.

The sash was locked by two (2) locks located at quarter points of sash and was hinged on the sides of frame. The sash was operated by slide hinge located at top of jambs.

All metal to metal joinery was sealed with joint sealant manufactured by Schlegal.

FORMAL TESTING

Tests were conducted on the 61 1/2" wide X 38" tall project out vent provided by Tubelite and installed into the test chamber by Winco personnel. Tests were conducted in substantial accordance with the test procedures outlined and described below utilizing the applicable AAMA and ASTM standards.

1. **2.1.2 AIR INFILTRATION TEST** (ASTM E 283) at 6.24 PSF (50 MPH and 1.2" H₂O).

ALLOWED: Air infiltration shall not exceed .3 CFM per square foot.

RESULTS: .03 CFM per square foot.

The tested specimen meets the performance levels specified in AAMA/NWWDA 101/I.S.2-97 and ASTM E 283.

2. **2.1.3 WATER RESISTANCE TEST** (ASTM E 547) at 12 PSF (69 MPH and 2.3" H₂O)

ALLOWED: No uncontrolled water infiltration to the room side.

RESULTS: No uncontrolled water infiltration to the room side.

The tested specimen meets the performance levels specified in AAMA/NWWDA 101/I.S.2-97 and ASTM E 547.

3. **2.2.4.5.9 LIFE CYCLE TESTING** (AAMA 910) for 2500 cycles.

	<u>TEST TITLE</u>	<u>ALLOWED</u>	<u>RESULT</u>
2.1.4	Vent cycle test 1250 cycles.	No damage	No damage
2.1.5	Locking hardware cycles.	No damage cycle test 1250	No damage
2.5.5.1	Ventilator Torsion test.	No damage	No damage
2.5.5.2	Balance Arm Load test.	No damage	No damage
2.5.5.3	Vent Lateral Racking test.	No damage	No damage
2.1.4	Vent cycle test 1250 cycles.	No damage	No damage
2.1.5	Locking hardware cycle test 1250 cycles.	No damage	No damage

The tested specimen meets the performance levels specified in AAMA/NWWDA 101/I.S.2-97 and AAMA 910-93.

4. **2.1.4.1 UNIFORM LOAD DEFLECTION TEST** (ASTM E 330) Held for ten (10) seconds duration for both 50% and 100% loads. Deflections were measured with dial indicators at both 50% and 100% loads.

+ 35.0 PSF (50% Positive Design Load) to remove slack
+ 70.0 PSF (100% Positive Design Load)
-35.0 PSF (50% Negative Design Load) to remove slack
-70.0 PSF (100% Negative Design Load)

ALLOWED: Deflection of framing members shall not exceed $L/175$ of the span length or .35". There shall be no failure of the system.

RESULTS: .34" maximum deflection and there was no failure of the system.

The tested specimen meets the performance levels specified in AAMA/NWWDA 101/I.S.2-97 and ASTM E 330.

5. **2.1.4.2 UNIFORM LOAD STRUCTURAL TEST** (ASTM E 330) at 1.5 times design load for ten (10) seconds duration in both directions. Deflections and permanent sets were measured at 1.5 times only.

+ 52.5 PSF (75% Positive Design Load) to remove slack
+105.0 PSF (150% Positive Design Load)
- 52.5 PSF (75% Negative Design Load) to remove slack
-105.0 PSF (150% Negative Design Load)

ALLOWED: Permanent set of framing members shall not exceed $2/1000$ of the span length or .12". There shall be no failure of the system.

RESULTS: .050" permanent set and there was no failure of the system.

The tested specimen meets the performance levels specified in AAMA/NWWDA 101/I.S.2-97 and ASTM E 330.

6. **2.1.8 FORCED ENTRY TEST** (ASTM F 588) Performance Grade 10

	<u>TEST TITLE</u>	<u>ALLOWED</u>	<u>RESULT</u>
10.1.1.1	Lock manipulation for 5 minutes.	No entry	No entry
10.1.1.2	Lock manipulation for 5 minutes.	No entry	No entry
10.2.2.1	Static load test at 75 pounds.	No entry	No entry
10.2.2.2	Static load test at 150 pounds.	No entry	No entry
10.2.2.3	Static load test at 150 pounds.	No entry	No entry
10.2.2.4	Lock manipulation for 5 minutes.	No entry	No entry

The tested specimen meets the performance levels specified in AAMA/NWWDA 101/I.S.2-97 and ASTM F 588.

7. **2.2.4.5.3 TORSION TEST** (AAMA 101.97)

ALLOWED: Maximum deflection of 1.670" at a concentrated load of 15 lbf.

RESULTS: The deflection did not exceed the allowable.

The tested specimen meets the performance levels specified in AAMA/NWWDA 101/I.S.2-97.

8. **2.2.4.5.4 HORIZONTAL CONCENTRATED LOAD TEST ON LATCH RAIL**
(AAMA 101-97)

ALLOWED: Maximum deflection of .06" at a concentrated load of 30 lbf.

RESULTS: The deflection did not exceed the allowable.

The tested specimen meets the performance levels specified in AAMA/NWWDA 101/I.S.2-97.

9. **2.2.4.5.5 VERTICAL CONCENTRATED LOAD TEST ON LATCH RAIL**
(AAMA 101-97)

ALLOWED: Maximum deflection of .06" at a concentrated load of 30 lbf.

RESULTS: The deflection did not exceed the allowable.

The tested specimen meets the performance levels specified in AAMA/NWWDA 101/I.S.2-97.

10. **2.2.4.5.6 TORSION LOAD TEST ON INTERMEDIATE FRAME RAILS**
(AAMA 101-97)

ALLOWED: Maximum deflection of .07" at a concentrated load of 40 lbf.

RESULTS: The deflection did not exceed the allowable.

The tested specimen meets the performance levels specified in AAMA/NWWDA 101/I.S.2-97.

11. **2.2.4.5.6 VERTICAL CONCENTRATED LOAD TEST ON INTERMEDIATE FRAME RAILS** (AAMA 101-97)

ALLOWED: Maximum deflection of .06" at a concentrated load of 30 lbf.

RESULTS: The deflection did not exceed the allowable.

The tested specimen meets the performance levels specified in AAMA/NWWDA 101/I.S.2-97.

12. **2.2.4.5.8 BALANCE ARM LOAD TEST** (AAMA 101-97)

ALLOWED: No damage to balance arms when subjected to a concentrated load of 60 lbf.

RESULTS: No damage to balance arms when subjected to a concentrated load of 60 lbf.

The tested specimen meets the performance levels specified in AAMA/NWWDA 101/I.S.2-97.

SUMMARY

The Series Zero-Sight Line Project-Out Vent Window unit as described in this report has met or exceeded all applicable test criteria set forth in AAMA/NWWDA 101/I.S.2-97 for a performance class of **AP-AW-70**.

This report or any portions thereof is valid for a period not to exceed four years and may not be reproduced by anyone or forwarded to anyone without written consent of Mid America Testing Laboratory. Participants referenced in the test report are welcome to a copy of this test report if so desired by the laboratory's client.

A bill of materials and die drawings are on file and have been compared to the sample submitted. Samples of the test specimen will be retained at the laboratory. A copy of this report will be forwarded to the validator.

Page 8
Tubelite Zero Sight-Line Curtain Wall
& Storefront Vent
December 17, 2001

The above results were secured by using the designated test methods, which indicate compliance with the performance requirements of the referenced specification. This report does not constitute certification of this product, which may only be granted by the validator.

Respectfully submitted,

MID AMERICA TESTING LABORATORY

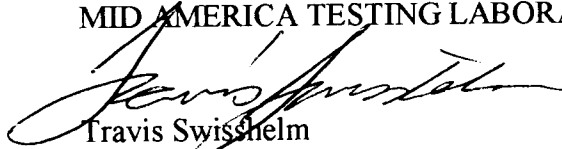

Travis Swischelm
Technical Services

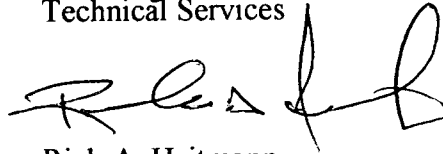

Rick A. Heitmann
President

TS,RAH:ljk
01108IPR-V2-Winco Zero-Sight Line Project-Out



Architectural Testing

AAMA 1503-98 THERMAL PERFORMANCE TEST REPORT

Rendered to:

TUBELITE, INC.
4878 Mackinaw Trail
Reed City, Michigan 49677

Report No: 01-40742.01
Test Date: 01/11/02
Report Date: 01/15/02
Expiration Date: 01/11/06

Test Sample Identification:

Series/Model: CVW3700 (Zero Sightline)

Type: Projecting (Awning)

Test Procedure: The condensation resistance factor (CRF) and thermal transmittance (U) were determined in accordance with AAMA 1503-98, *Voluntary Test Method for Thermal Transmittance and Condensation Resistance of Windows, Doors and Glazed Wall Sections*.

- | | |
|---|--------|
| 1. Average warm side ambient temperature | 70.0 F |
| 2. Average cold side ambient temperature | 0.0 F |
| 3. 15 mph dynamic wind applied to test specimen exterior. | |
| 4. 0.0" \pm 0.04" static pressure drop across specimen. | |

Test Results Summary:

- | | |
|---|------|
| 1. Condensation resistance factor – Frame (CRF _f) | 47 |
| Condensation resistance factor – Glass (CRF _g) | 54 |
| 2. Thermal transmittance due to conduction (U _c) | 0.65 |
| (U-factors expressed in Btu/hr-ft ² -F) | |

130 Derry Court
York, PA 17402-9405
phone: 717.764.7700
fax: 717.764.4129
www.archtest.com



Test Sample Description:

CONSTRUCTION	Frame	Vent
Size (in.)	61.38 x 37.38	59.75 x 35.75
Daylight Opening (in.)	NA	56.25 x 32.25
CORNERS	Coped	Mitered
Fasteners	Screws	Keys & Stakes
Sealant	Corners	None
MATERIAL	AT (0.27")	AL
Color Exterior	Gray	Gray
Finish Exterior	Anodized	Anodized
Color Interior	Gray	Gray
Finish Interior	Anodized	Anodized
GLAZING METHOD	NA	Exterior

GLAZING	Sheet #1	Gap #1	Sheet #2
Thickness (in.)	0.152	0.684	0.154
Coating Emissivity	NA	NA	NA
Coating Surface	NA	NA	NA
Spacer/Sealant	NA	S1 (Steel)	NA
Material	Tempered	Air*	Tempered
Gas Fill Method	NA		

* -- Stated per Client/Manufacturer
 NA --Non-Applicable
 See Appendix A for Description Codes



Test Sample Description: (Continued)

COMPONENTS		
Type	Quantity	Location
WEATHERSTRIP		
Wrapped foam gasket	2 Rows	Vent perimeter
Single-leaf gasket	1 Row	Vent perimeter
HARDWARE		
Metal sweep lock	2	Bottom rail
Metal keeper with vinyl sweep pad	2	Sill
Multi-arm hinge	2	Hinge jambs
DRAINAGE		
No weeps		



Test Duration:

1. The environmental systems were started at 14:29 hrs., 01/10/02
2. The thermal performance test results were derived from 05:54 hrs., 01/11/02 to 07:54 hrs., 01/11/02.

Condensation Resistance Factor (CRF):

The following information, condensed from the test data, was used to determine the condensation resistance factor:

T_h	=	Warm side ambient air temperature	70.00 F
T_c	=	Cold side ambient air temperature	-0.01 F
FT_p	=	Average of pre-specified frame temperatures (14)	33.45 F
FT_r	=	Average of roving thermocouples (4)	26.23 F
W	=	$(FT_p - FT_r) / [FT_p - (T_c + 10)] \times 0.40$	0.123
FT	=	$FT_p(1-W) + W (FT_r) =$ Frame Temperature	32.56 F
GT	=	Glass Temperature	37.71 F
CRF_g	=	Condensation resistance factor – Glass	54
		$CRF_g = (GT - T_c) / (T_h - T_c) \times 100$	
CRF_f	=	Condensation resistance factor - Frame	47
		$CRF_f = (FT - T_c) / (T_h - T_c) \times 100$	

The CRF number was determined to be 47 (on the size as reported). When reviewing this test data, it should be noted that the frame temperature (FT) was colder than the glass temperature (GT) therefore controlling the CRF number. Refer to the 'CRF Report' page and the 'Thermocouple Location Diagram' page of this report.



Thermal Transmittance (U_c):

T_h	=	Average warm side ambient temperature	70.00 F
T_c	=	Average cold side ambient temperature	-0.01 F
P	=	Static pressure difference across test specimen	0.00 psf
		15 mph dynamic perpendicular wind at exterior	
		Nominal sample area	15.93 ft ²
		Total measured input to calorimeter	871.61 Btu/hr
		Calorimeter correction	148.08 Btu/hr
		Net specimen heat loss	723.53 Btu/hr
U_c	=	Thermal Transmittance	0.65 Btu/hr-ft ² -F

Glazing Deflection (in.):

	Vent
Thickness at edge	0.99
Center thickness upon receipt of specimen in laboratory (after stabilization)	0.92
Center thickness at laboratory ambient conditions on day of testing	0.92
Center thickness at test conditions	0.97

The test sample was inspected for the formation of frost or condensation which may influence the surface temperature measurements. Any observed condensation/frost is indicated on the 'Thermocouple Location Diagram.'

A calibration of the ATI 'thermal test chamber' in York, Pennsylvania was conducted in June 2001.



Thermocouple Location Diagram

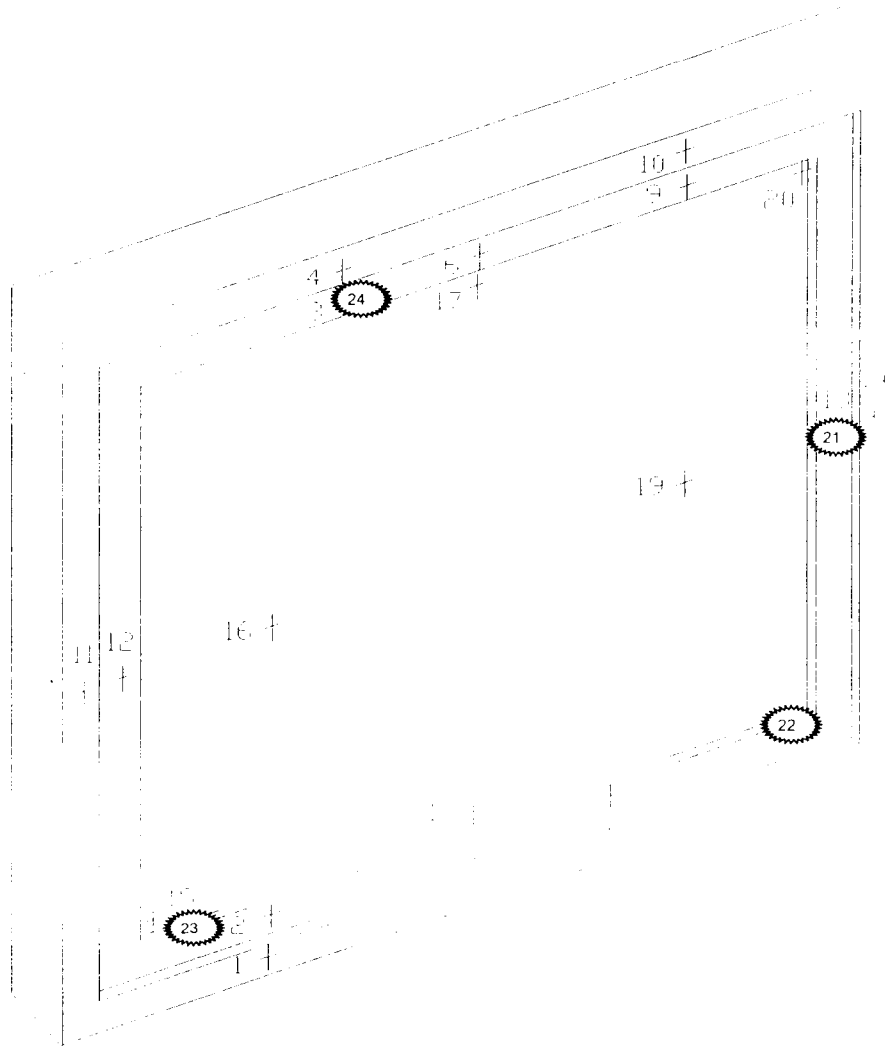

Cold Point Locations

- 21. 24.3
- 22. 25.5
- 23. 27.5
- 24. 27.6



Detailed drawings, representative samples of the test specimen and a copy of this report will be retained by ATI for a period of four years. This report is the exclusive property of the client so named herein and is applicable to the sample tested. This report may not be reproduced, except in full, without the approval of the laboratory. Results obtained are tested values and do not constitute an opinion or endorsement by this laboratory.

For ARCHITECTURAL TESTING, INC.

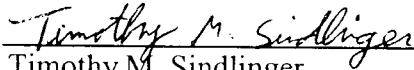

Timothy M. Sindlinger
Technician



Michael J. Thoman
Individual-In-Responsible-Charge



DOCUMENT CONTROL ADDENDUM #01-40742.00

Current Issue Date: 01/15/02

Report No.: 01-40742.01

Requested by: Steve DeYoung, Tubelite, Inc.

Purpose: Condensation Resistance Factor (CRF) and Thermal Transmittance (U) were determined in accordance with AAMA 1503-98 on Series/Model CVW3700 (Zero Sightline).

Issued Date: 01/15/02

Comments:



Description Table Abbreviations

CODE	Frame / Sash Types
AI	Aluminum w/ Vinyl Inserts (Caps)
AL	Aluminum
AP	Aluminum w/ Thermal Breaks - Partial
AS	Aluminum w/ Steel Reinforcement
AT	Aluminum w/ Thermal Breaks - All Members
AV	Aluminum / Vinyl Composite
AW	Aluminum-clad Wood
FG	Fiberglass
N	Not Applicable
OT	Other
PA	ABS Plastic w/ All Members Reinforced
PC	ABS Plastic-clad Aluminum
PF	ABS Plastic w/ Foam-filled Insulation
PH	ABS Plastic w/ Horizontal Members Reinforced
PI	ABS Plastic w/ Reinforcement - Interlock
PL	ABS Plastic
PP	ABS Plastic w/ Reinforcement - Partial
PV	ABS Plastic w/ Vertical Members Reinforced
PW	ABS Plastic-clad Wood
ST	Steel
VA	Vinyl w/ All Members Reinforced
VC	Vinyl-clad Aluminum
VF	Vinyl w/ Foam-filled Insulation
VH	Vinyl w/ Horizontal Members Reinforced
VI	Vinyl w/ Reinforcement - Interlock
VP	Vinyl w/ Reinforcement - Partial
VV	Vinyl w/ Vertical Members Reinforced
VW	Vinyl-clad Wood
VY	Vinyl
WA	Aluminum / Wood composite
WD	Wood
WV	Vinyl / Wood composite

DOOR DETAILS	
CODE	Door Type
EM	Embossed
FL	Flush
LF	Full Lite
LH	1/2 - Lite
LQ	1/4 - Lite
LT	3/4 - Lite
N	Not Applicable
RP	Raised Panel

CODE	Skin
AL	Aluminum
FG	Fiberglass
GS	Galvanized Steel
N	Not Applicable
ST	Steel
WD	Wood

CODE	Panel
FG	Fiberglass
N	Not Applicable
PL	Plastic
WP	Wood - Plywood
WS	Wood - Solid

CODE	Sub-Structure
GS	Galvanized Steel
N	Not Applicable
PL	Plastic
ST	Steel
WD	Wood

CODE	Core Fill
CH	Cellular - Honeycomb
EP	Expanded Polystyrene
N	Not Applicable
PI	Polyisocyanurate
PU	Polyurethane
WP	Wood - Plywood
WS	Wood - Solid
XP	Extruded Polystyrene

CODE	Sealant
D	Dual Seal Spacer System
N	Not Applicable
S	Single Seal Spacer System

CODE	Thermal Breaks
F	Foam
N	Not Applicable
O	Other
U	Urethane
V	Vinyl

CODE	Spacer Types
A1	Aluminum
A2	Aluminum (Thermally-broken)
A3	Aluminum-reinforced Polymer
A4	Aluminum / Wood
A5	Aluminum-reinforced Butyl
A6	Aluminum / Foam / Aluminum
A7	Aluminum U-shaped
ER	EPDM Reinforced Butyl
FG	Fiberglass
GL	Glass
N	Not Applicable
OF	Organic Foam
PU	Polyurethane Foam
S1	Steel
S2	Steel (Thermally-broken)
S3	Steel / Foam / Steel
S4	Steel U-shaped
S5	Steel-reinforced Butyl
S6	Steel U-channel w/ Thermal Cap
TP	Thermo-plastic
V1	Vinyl U-shaped
WD	Wood
ZF	Silicone Foam
ZS	Silicone / Steel

CODE	Interspace Gas Fill
AIR	Air
AR2	Argon / Krypton Mixture
AR3	Argon / Krypton / Air Mixture
ARG	Argon
CO2	Carbon Dioxide
KRY	Krypton
N	Not Applicable
OT	Other
SF6	Sulphur Hexafluoride
U	Unknown

CODE	Grid Description
B	Optional (With or Without)
N	No Muntins
S	Simulated Divided Lites
T	True Muntins
Y	Internal muntins

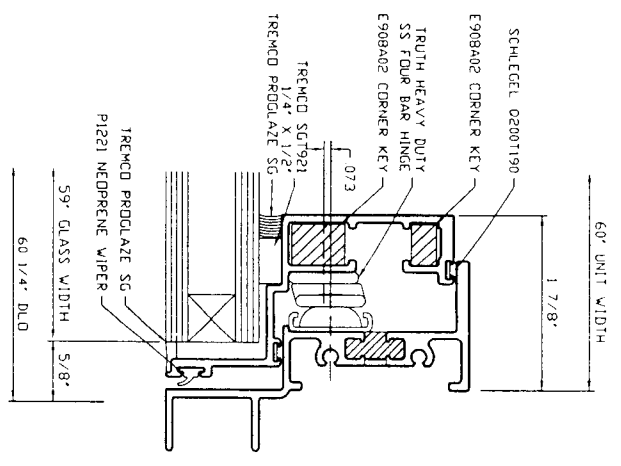
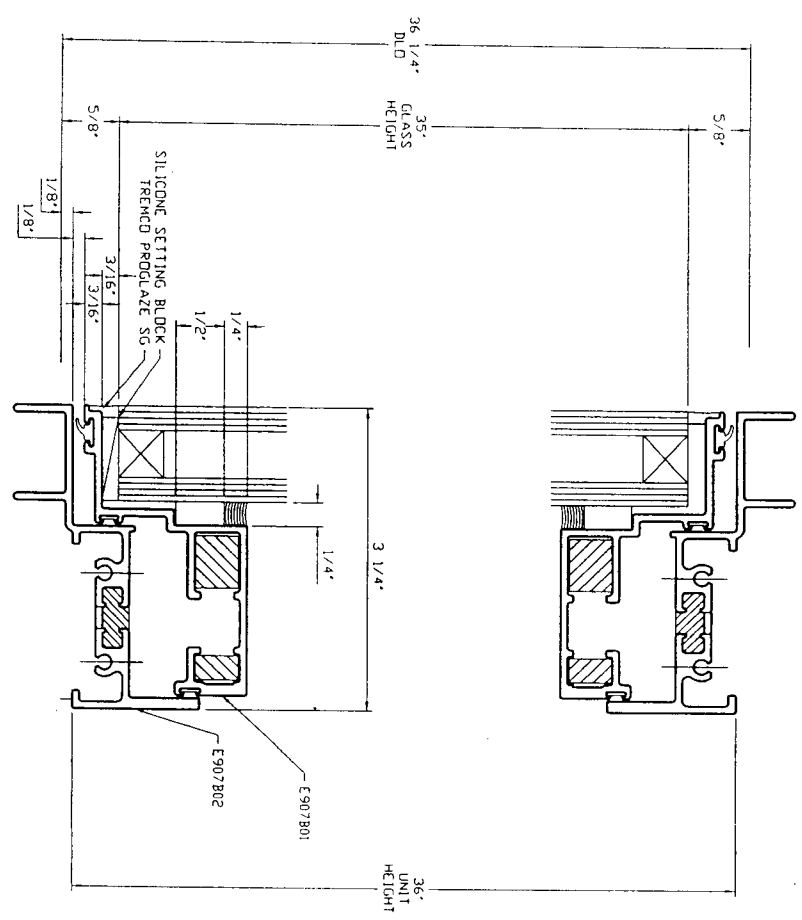

TEST SPECIMEN COMPLIES WITH THESE DETAILS.
 ANY DEVIATION IS NOTED.
 PROJ. ATR. CI-40742 TEST DATE 11/6/02
 INITIALS JMS

SCALE	3/4 SIZE	JOB NAME	PROJECT DUT - ZERO SIGHTLINE
DRAWN BY	SRD	LOCATION	VENT WINDOW ASSEMBLY
REVISED		ARCHITECT	TUBELITE INC.
		CUSTOMER	REED CITY, MI
©2000 TUBELITE INC. ALL RIGHTS RESERVED TUBELITE STORMWINDS & ENTRANCES		4878 MACKINAW TRAIL REED CITY, MICHIGAN 49677	
DATE	8/31/01	SHEET	1 OF 1
		ISSUING	OSLTEST

