

# HW 3700

## PROJECT-IN VENT WINDOW



### FEATURES:

AAMA/WDMA/CSA101/15.2/A440-  
08/NAFS CLASS CW-PG40  
[60X36]-AP

LIFE CYCLE TESTED

2" FRAME DEPTH

SCREW-SPLINE FRAME JOINERY

MITERED CLIP, EPOXY AND STAKE  
JOINERY

POUR & DEBRIDGE THERMAL BREAK

FIELD GLAZING

EPDM GASKETS

1/4" & 1" GLASS THICKNESS

ALUMINUM GLASS STOPS

CAM LOCKS

4-BAR HINGES

EQUAL FRAME LEGS

ANODIZED & PAINTED FINISHES

OPTIONAL ALUMINUM SCREENS WITH

FRAME FINISHED TO MATCH

WINDOW

**TUBELITE®**  
**DEPENDABLE**

LEADERS IN ECO-EFFICIENT STOREFRONT,  
CURTAINWALL AND ENTRANCE SYSTEMS



4-BAR HINGE



CAM LOCK

**1/2 SIZE DETAILS**

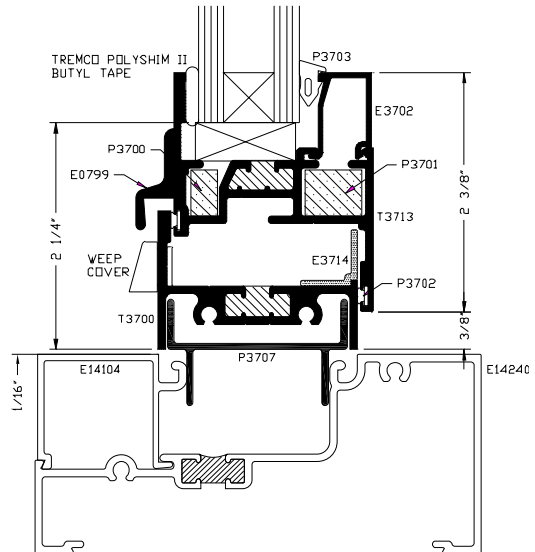
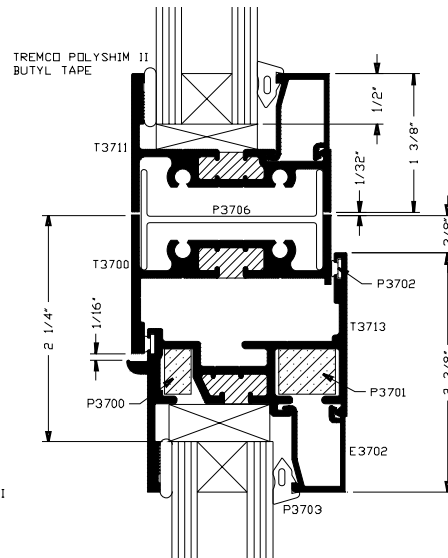
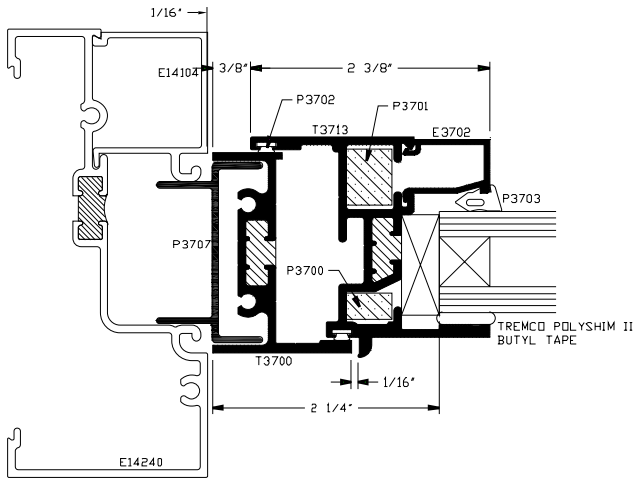

# HW3700 – VENT WINDOW GUIDE SPECIFICATIONS

## GENERAL

### Description

Furnish all necessary materials, labor and equipment for the complete installation of aluminum windows as shown on the drawings and specified herein.

Project-out vent windows shall be HW3700 (2 3/8" x 2 1/4") as manufactured by Tubelite Inc., Walker, Michigan. Whenever substitute products are to be considered, supporting technical literature, samples drawings and performance data must be submitted ten (10) days prior to bid in order to make a valid comparison of the products involved.

Test reports certified by an independent laboratory must be made available upon request.

### Performance Requirements

Air infiltration shall not exceed .3 CFM/Ft<sup>2</sup> when tested in accordance with ASTM E-283 at a test pressure of 6.27 PSF.

There shall be no uncontrolled water entry when tested in accordance with ASTM E-331 "Water Penetration of Exterior Windows, Curtainwalls and Doors by Uniform Static Air Pressure Difference" at a test pressure of 6 PSF.

Structural performance per ASTM E-330 shall be based on a maximum allowable deflection of L/175 of the span. The system shall perform to those criteria under a design test pressure of 40 PSF.

Windows shall meet the performance specification AAMA/WDMA/CSA101/15.2/A440-08/NAFS Class CW-PG40 [60x36]-AP ratings.

## PRODUCTS

### Construction

The 2" deep, standard equal leg frame is fabricated from extruded aluminum, with .125" minimum wall thickness. Joints are coped, double screw fastened, and sealed with small joint sealer.

The sash is fabricated from extruded aluminum, with .075" minimum wall thickness. Mitered hairline joints are mechanically staked to solid aluminum, internal corner keys, and sealed with small joint sealer.

Glass stops are 3/4" high and can accept either 1" or 1/4" thick glazing material.

### Materials

Extrusions shall be of aluminum alloy 6063-T5 extruded within commercial tolerance and free from defects impairing strength and/or durability.

Screws, bolts and all other accessories to be compatible with the aluminum under normal service conditions.

Glazing shall be by means of an exterior pre-formed adhesive tape, and interior roll-in wedge of high quality extruded elastomeric material.

Weathering consists of double Santoprene bulb gasket, continuous at perimeter.

Thermal barrier shall be a two part chemically curing, unfilled polyurethane casting resin poured in place for perimeter members.

### Finish

All exposed framing surfaces shall be free of scratches and other serious blemishes.

Finish to be: (architect select)

Etched and clear anodized  
(AAM10C21A31)

Clear - Class 2 (C2)

(AAM10C21A41)

Clear - Class 1 (C1)

Electrolytically deposited color  
(AAM10C21A44) Class 1

Champagne (CH)

Light Bronze (LB)

Medium Bronze (MB)

Dark Bronze (DB)

Extra Dark Bronze (EB)

Black (BL)

Fluoropolymer painted color \_\_\_\_\_.

## EXECUTION

### Installation

Installation shall be in accordance with the manufacturer's installation instructions and the approved shop drawings.

### Note:

In keeping with Tubelite's policy of continuing product improvements, all specifications are subject to change without written notice by the manufacturer.

# Vents

## Project-In Jamb - T14000 Series

CAD DETAIL FILE NO.  
120JAMB7

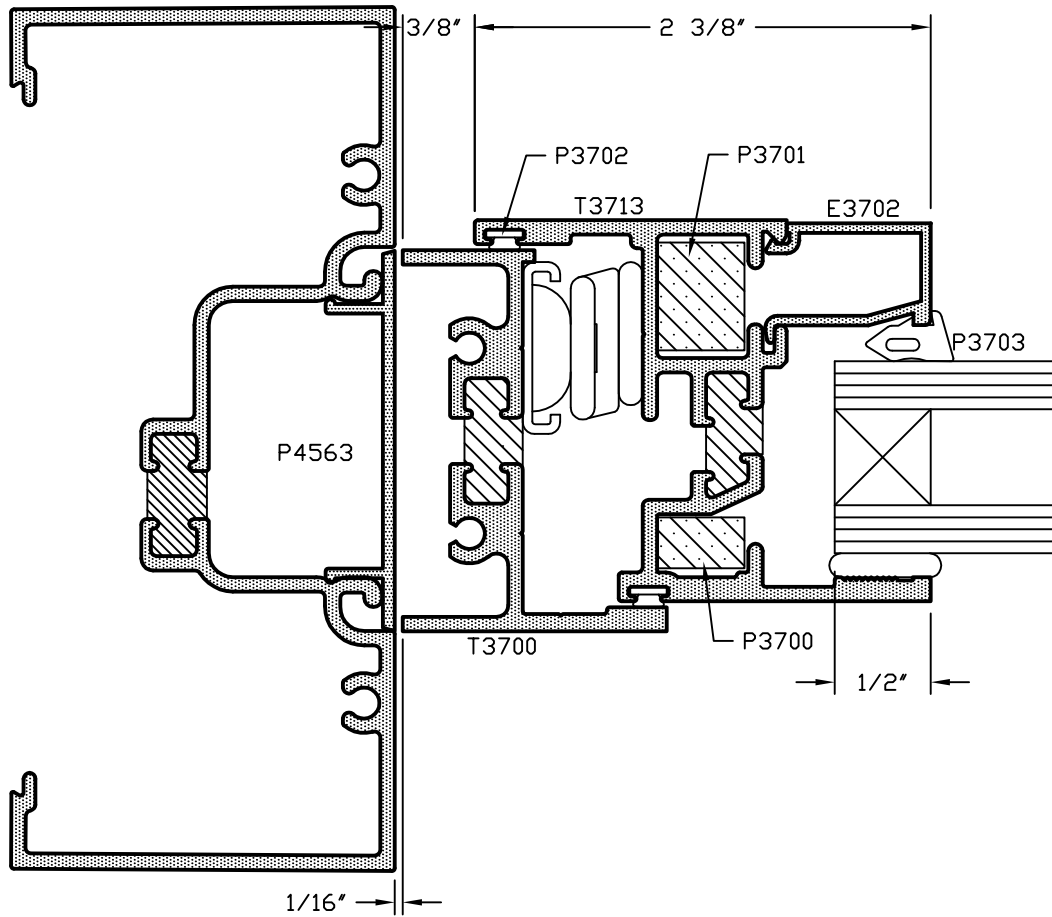

# Vents

## Project-In Sill - T14000 Series

CAD DETAIL FILE NO.  
120SILL7

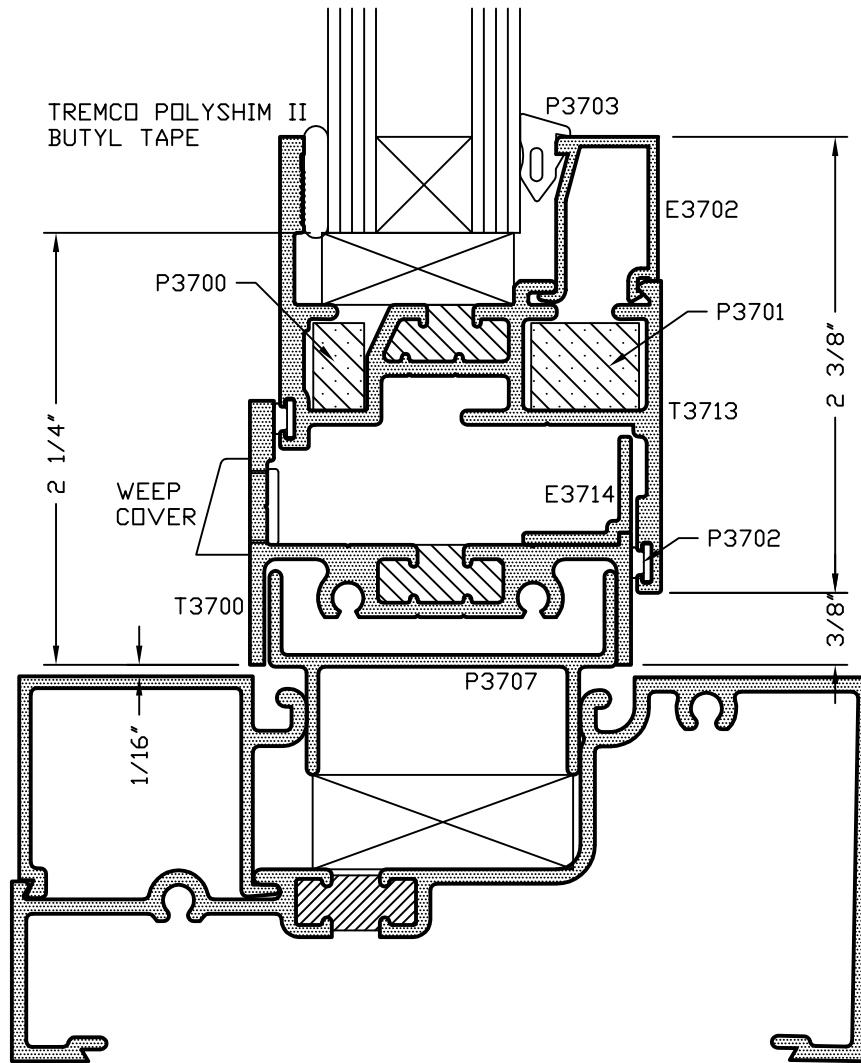

# Vents

## Project-In Sill - 400 CW

CAD DETAIL FILE NO.  
120SILL8

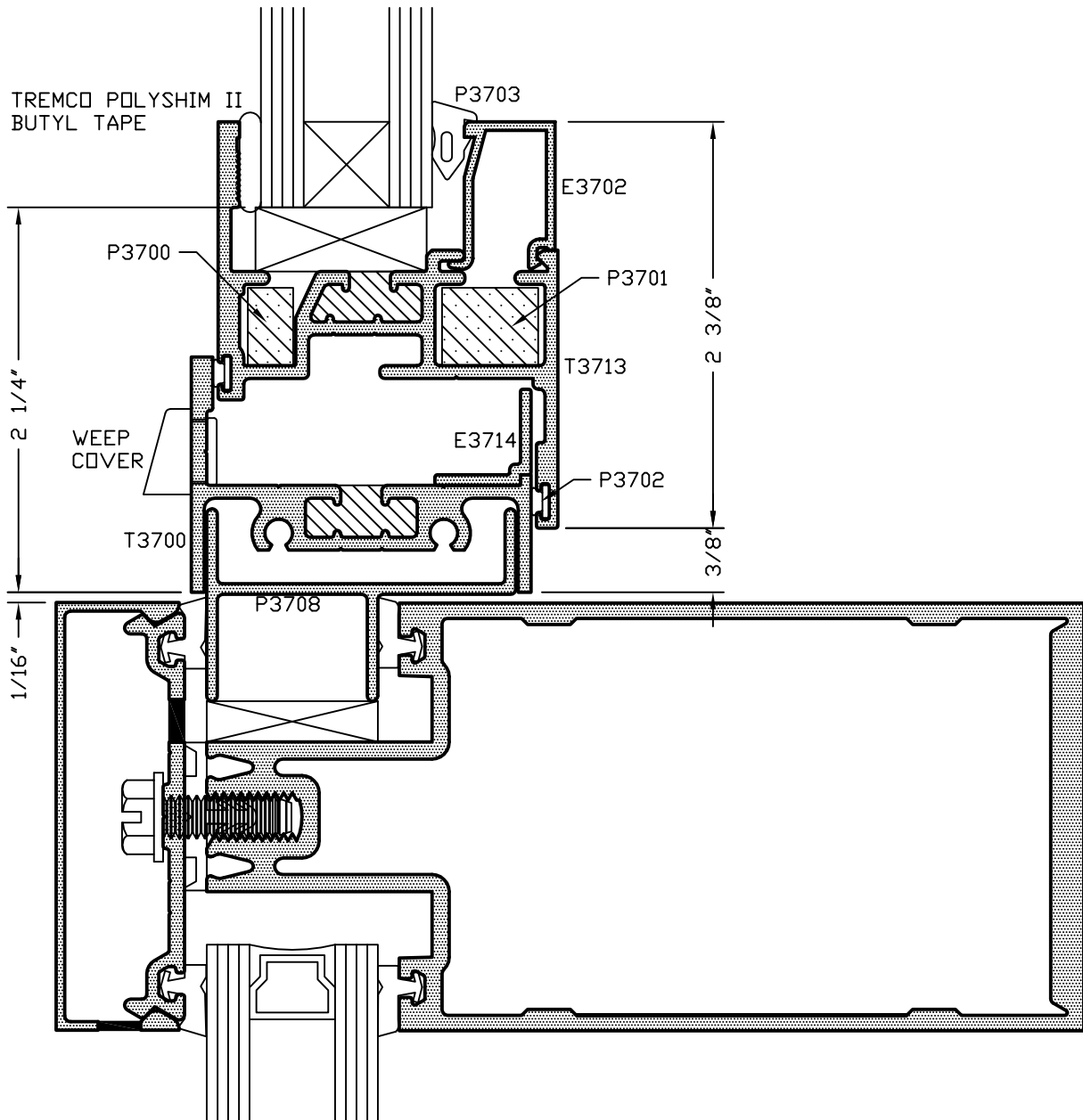

# Concealed Vent Windows

## Screen Detail - 1/2 Scale

CAD DETAIL FILE NO.  
120SCREEN

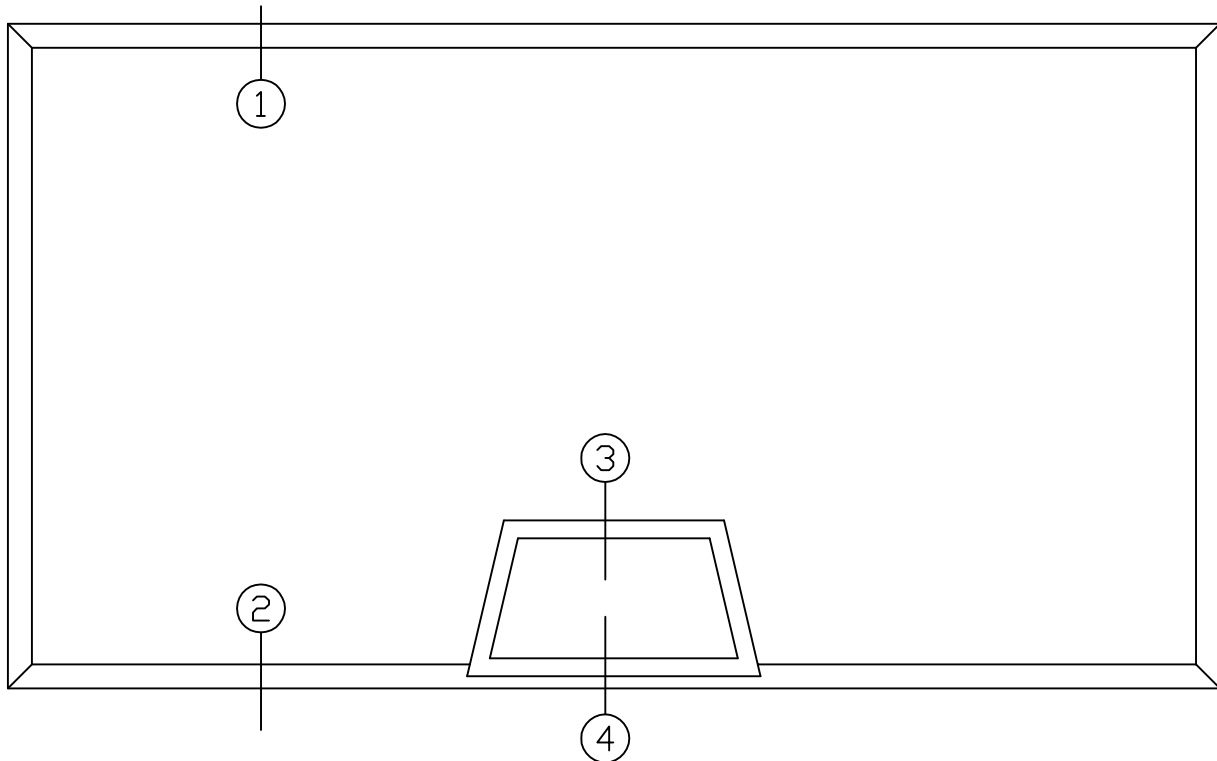

INTERIOR ELEVATION

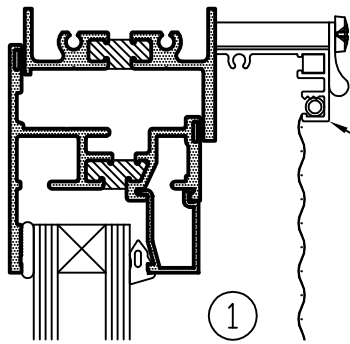

E3710 SCREEN FRAME (TYP)  
MITERED WITH CORNER  
KEY AND #10 SCREWS

WICKET FOR ACCESS  
TO CAM HANDLE

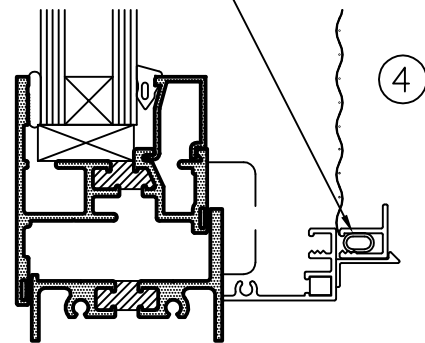
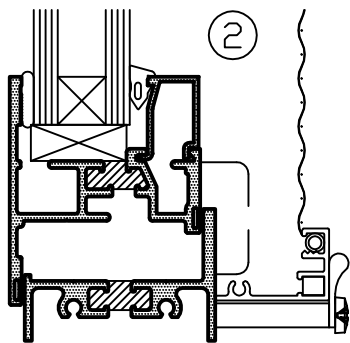

# Concealed Vent Windows

## Screen Detail - 1/2 Scale

CAD DETAIL FILE NO.  
120SCREEN1

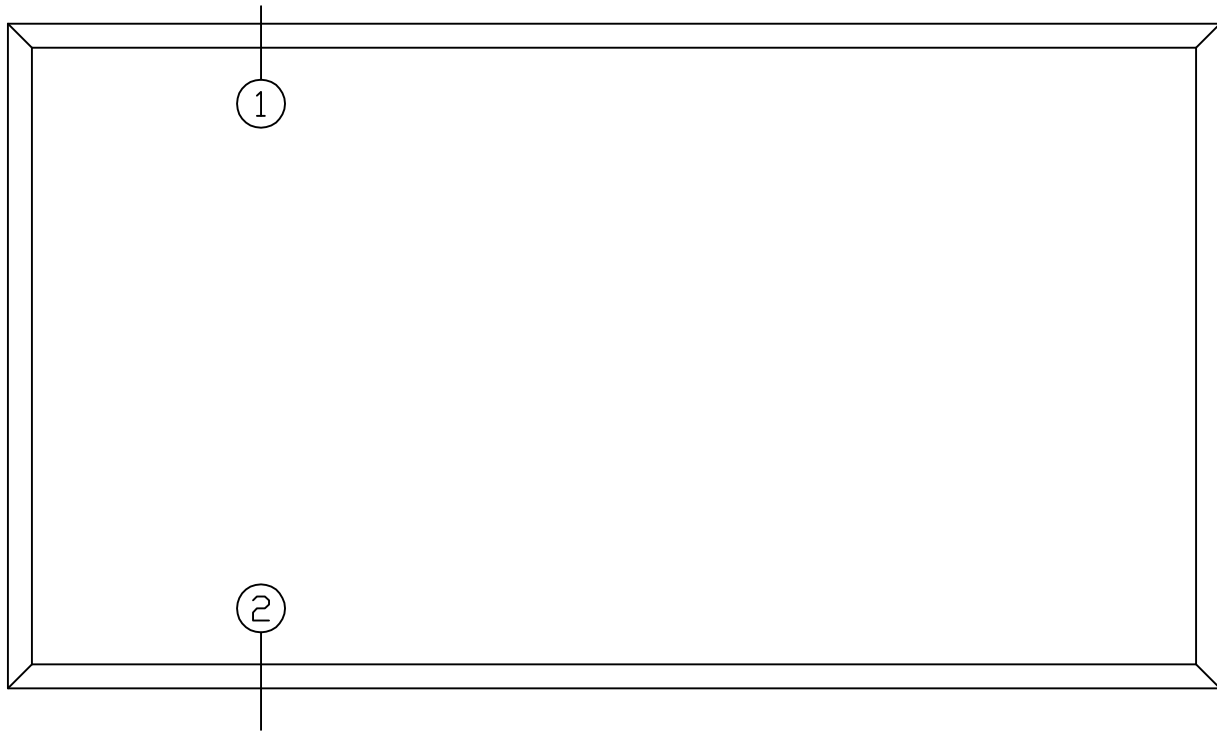

INTERIOR ELEVATION

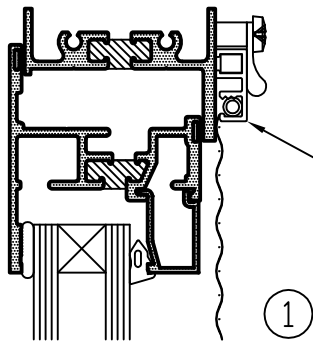

E3720 SCREEN FRAME (TYP)  
MITERED WITH CORNER  
KEY AND #10 SCREWS

