

**AAMA 1503-09 THERMAL PERFORMANCE
TEST REPORT**

Rendered to:

TUBELITE, INC.

SERIES/MODEL: HW3700 Hopper Window

TYPE: Projecting (Awning)

Summary of Results	
Thermal Transmittance (U-Factor)	0.46
Condensation Resistance Factor - Frame (CRF _f)	55
Condensation Resistance Factor - Glass (CRF _g)	69
Unit Size	59" x 23-5/8" (1499 mm x 600 mm)
Layer 1	1/4" PPG Solarban 60 (e=0.035*, #2) Tempered
Gap 1	0.47" Gap, Technoform TGI Spacer (TS-D), 90% Argon-Filled*
Layer 2	1/4" Clear Tempered

Reference must be made to Report No. A4283.02-116-46, dated 10/29/10 for complete test specimen description and data.

AAMA 1503-09 THERMAL PERFORMANCE TEST REPORT

Rendered to:

TUBELITE, INC.
4878 Mackinaw Trail
Reed City, Michigan 49677

Report Number: A4283.02-116-46
Test Date: 10/20/10
Report Date: 10/29/10
Test Record Retention Date: 10/20/14

Test Sample Identification:

Series/Model: HW3700 Hopper Window

Type: Projecting (Awning)

Test Sample Submitted by: Client

Test Procedure: The condensation resistance factor (CRF) and thermal transmittance (U) were determined in accordance with AAMA 1503-09, *Voluntary Test Method for Thermal Transmittance and Condensation Resistance of Windows, Doors and Glazed Wall Sections*

- | | |
|---|---------|
| 1. Average warm side ambient temperature | 69.80 F |
| 2. Average cold side ambient temperature | -0.40 F |
| 3. 15 mph dynamic wind applied to test specimen exterior. | |
| 4. 0.0" \pm 0.04" static pressure drop across specimen. | |

Test Results Summary:

- | | |
|--|------|
| 1. Condensation resistance factor - Frame (CRF _f) | 55 |
| Condensation resistance factor - Glass (CRF _g) | 69 |
| 2. Thermal transmittance due to conduction (U)
(U-factors expressed in Btu/hr·ft ² ·F) | 0.46 |

Test Sample Description:

CONSTRUCTION	Frame	Vent
Size (in.) Non-Standard	59" x 23-5/8"	58-3/8" x 23"
Daylight Opening (in.)	N/A	53-1/2" x 18-1/4"
CORNERS	Coped	Mitered
Fasteners	Screws	Keys & Stakes
Sealant	Yes	Yes
MATERIAL	AT (0.22")	AT (0.24")
Color Exterior	Black	Black
Finish Exterior	Anodized	Anodized
Color Interior	Black	Black
Finish Interior	Anodized	Anodized
GLAZING METHOD	N/A	Interior

Glazing Information:

Layer 1	1/4" PPG Solarban 60 (e=0.035*, #2) Tempered
Gap 1	0.47" Gap, Technoform TGI Spacer (TS-D), 90% Argon-Filled*
Layer 2	1/4" Clear Tempered
Gas Fill Method	Single-Probe Method*
Desiccant	Yes

**Stated per Client/Manufacturer*

NA Non-Applicable

See Description Table Abbreviations

Test Sample Description: (Continued)

COMPONENTS		
Type	Quantity	Location
WEATHERSTRIP		
Flexible hollow bulb gasket	2 rows	Vent perimeter
HARDWARE		
1/4 Turn lever lock handles	2	Top rail
Metal keepers	2	Head
Multi-arm hinge	2	Jambs/stiles
DRAINAGE		
(1.13" x 0.25") weepslot with cover	2	Sill face

Test Duration:

1. The environmental systems were started at 06:57 hours, 10/19/10.
2. The thermal performance test results were derived from 13:03 hours, 10/20/10 to 17:03 hours, 10/20/10.

Condensation Resistance Factor (CRF):

The following information, condensed from the test data, was used to determine the condensation resistance factor:

T_h	=	Warm side ambient air temperature	69.80 F
T_c	=	Cold side ambient air temperature	-0.40 F
FT_p	=	Average of pre-specified frame temperatures (14)	38.13 F
FT_r	=	Average of roving thermocouples (4)	34.45 F
W	=	$[(FT_p - FT_r) / (FT_p - (T_c + 10))]$ x 0.40	0.052
FT	=	$FT_p(1-W) + W (FT_r)$ = Frame Temperature	37.94 F
GT	=	Glass Temperature	47.90 F
CRF_g	=	Condensation resistance factor – Glass	69
		$CRF_g = (GT - T_c) / (T_h - T_c) \times 100$	
CRF_f	=	Condensation resistance factor – Frame	55
		$CRF_f = (FT - T_c) / (T_h - T_c) \times 100$	

The CRF number was determined to be 55 (on the size as reported). When reviewing this test data, it should be noted that the frame temperature (FT) was colder than the glass temperature (GT) therefore controlling the CRF number. Refer to the 'CRF Report' page and the 'Thermocouple Location Diagram' page of this report.

Thermal Transmittance (U_c):

T_h	= Average warm side ambient temperature	69.80 F
T_c	= Average cold side ambient temperature	-0.40 F
P	= Static pressure difference across test specimen 15 mph dynamic perpendicular wind at exterior	0.00 psf
	Nominal sample area	9.68 ft ²
	Total measured input to calorimeter	469.20 Btu/hr
	Calorimeter correction	154.07 Btu/hr
	Net specimen heat loss	315.13 Btu/hr
U	= Thermal Transmittance	0.46 Btu/hr·ft ² ·F

Glazing Deflection (in.):

	Vent
Edge Gap Width	0.47
Estimated center gap width upon receipt of specimen in laboratory (after stabilization)	0.47
Center gap width at laboratory ambient conditions on day of testing	0.47
Center gap width at test conditions	0.41

The sample was inspected for the formation of frost or condensation, which may influence the surface temperature measurements. The sample showed no evidence of condensation/frost at the conclusion of the test.

A calibration of the Architectural Testing Inc. 'thermal test chamber' (ICN 000001) in York, Pennsylvania was conducted in May 2010 in accordance with Architectural Testing Inc. calibration procedure.

Prior to testing the specimen was sealed with silicone on the interior side and checked for air infiltration per Section 9.3.4.



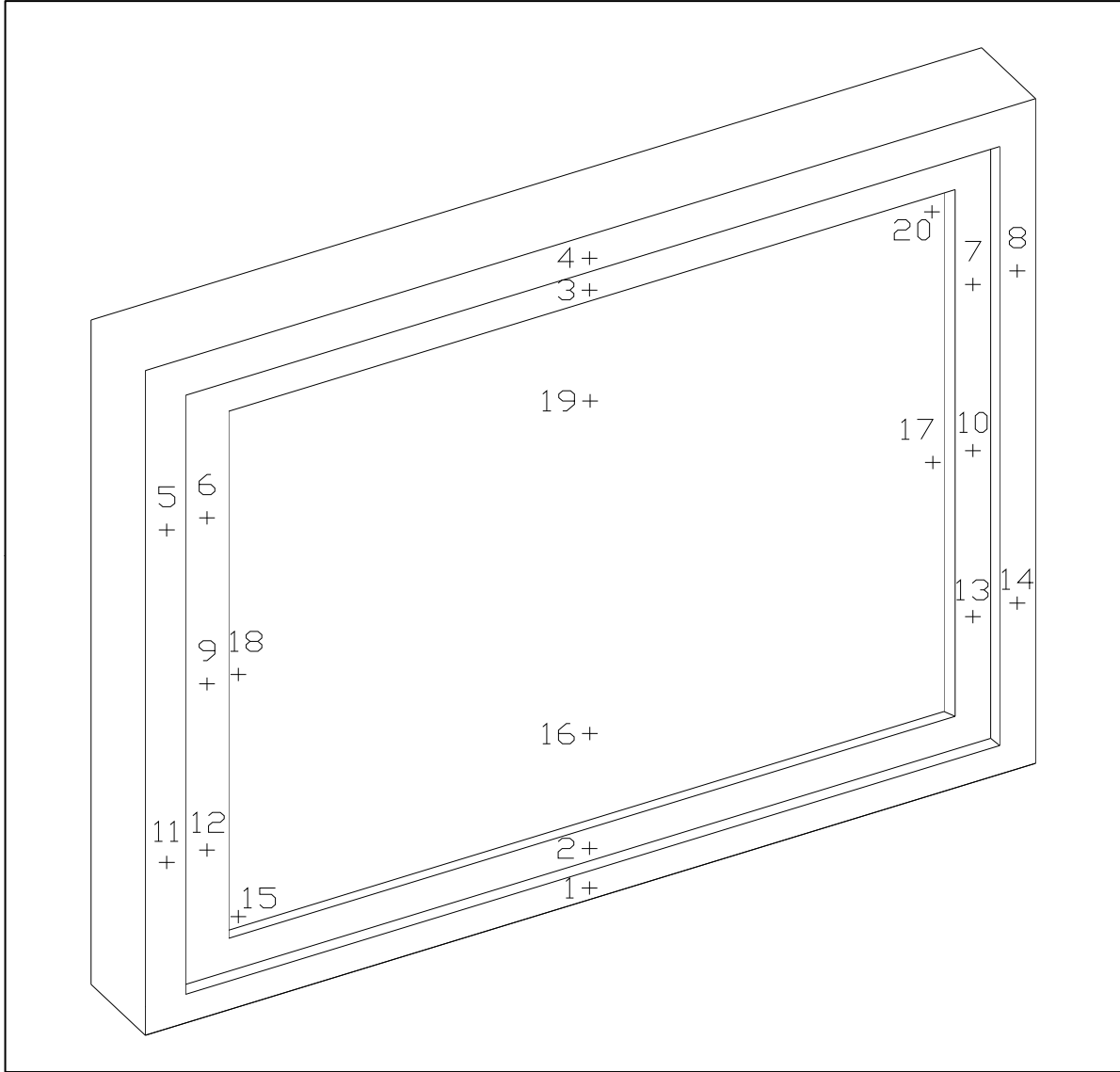

CRF Report

Time:	15:03	15:33	16:03	16:33	17:03	AVERAGE
Pre-specified Thermocouples - Frame						
1	33.73	33.72	33.66	33.68	33.65	33.69
2	35.64	35.65	35.61	35.60	35.56	35.61
3	41.44	41.43	41.42	41.45	41.44	41.44
4	37.93	37.91	37.92	37.87	37.87	37.90
5	34.94	34.93	34.89	34.84	34.86	34.89
6	42.15	42.14	42.16	42.12	42.13	42.14
7	33.73	33.75	33.68	33.73	33.63	33.70
8	37.22	37.21	37.19	37.17	37.13	37.19
9	41.72	41.70	41.71	41.72	41.71	41.71
10	40.01	40.01	40.00	40.01	39.98	40.00
11	36.37	36.34	36.33	36.32	36.37	36.35
12	40.25	40.18	40.24	40.25	40.24	40.23
13	41.96	41.99	41.94	41.88	41.87	41.93
14	37.09	37.11	37.09	37.08	37.11	37.10
FT _p	38.15	38.15	38.13	38.12	38.11	38.13
Pre-specified Thermocouples - Glass						
15	38.00	37.99	37.94	37.97	37.95	37.97
16	56.08	56.09	56.06	56.12	56.11	56.09
17	48.33	48.28	48.31	48.33	48.30	48.31
18	39.78	39.75	39.73	39.73	39.68	39.74
19	57.77	57.83	57.87	57.87	57.88	57.84
20	47.47	47.46	47.47	47.48	47.44	47.46
GT	47.90	47.90	47.90	47.92	47.89	47.90
Cold Point (Roving) Thermocouples						
21	33.70	33.70	33.70	33.70	33.70	33.70
22	33.70	33.70	33.70	33.70	33.70	33.70
23	34.90	34.90	34.90	34.90	34.90	34.90
24	35.50	35.50	35.50	35.50	35.50	35.50
FT _R	34.45	34.45	34.45	34.45	34.45	34.45
W	0.05	0.05	0.05	0.05	0.05	0.05
FT	37.96	37.96	37.94	37.93	37.92	37.94
Warm Side - Room Ambient Air Temperature						
	69.80	69.79	69.80	69.82	69.81	69.80
Cold Side - Room Ambient Air Temperature						
	-0.42	-0.36	-0.42	-0.33	-0.44	-0.39
CRF _f	55	55	55	55	55	55
CRF _g	69	69	69	69	69	69

Thermocouple Location Diagram



Cold Point Locations

- | | |
|---|-----------|
|  | 21. 33.70 |
|  | 22. 33.70 |
|  | 23. 34.90 |
|  | 24. 35.50 |

Detailed drawings, data sheets, representative samples of test specimens, a copy of this report, or other pertinent project documentation will be retained by Architectural Testing, Inc. for a period of four years from the original test date. At the end of this retention period such materials shall be discarded without notice and the service life of this report by Architectural Testing will expire. Results obtained are tested values and were secured by using the designated test methods. This report does not constitute certification of this product nor an opinion or endorsement by this laboratory. It is the exclusive property of the client so named herein and relates only to the specimen(s) tested. This report may not be reproduced, except in full, without the written approval of Architectural Testing, Inc.

For ARCHITECTURAL TESTING, INC.

Ryan P. Moser
Technician

Shon W. Einsig
Senior Technician
Individual-In-Responsible-Charge

RPM:ake
A4283.02-116-46

Attachments (pages): This report is complete only when all attachments listed are included.

Appendix-A: Description Table Abbreviations (1)

Appendix-B: Drawings (6)

Revision Log

<u>Rev. #</u>	<u>Date</u>	<u>Page(s)</u>	<u>Revision(s)</u>
.02R0	10/29/10	All	Original Report Issue. Work requested by Steve Wilkening of Tubelite, Inc.

Appendix A: Description Table Abbreviations

CODE	Frame / Sash Types
AI	Aluminum w/ Vinyl Inserts (Caps)
AL	Aluminum
AP	Aluminum w/ Thermal Breaks - Partial
AS	Aluminum w/ Steel Reinforcement
AT	Aluminum w/ Thermal Breaks - All Members (> 0.21")
AU	Aluminum Thermally Improved - All Members (0.062" - 0.209")
AV	Aluminum / Vinyl Composite
AW	Aluminum-clad Wood
FG	Fiberglass
PA	ABS Plastic w/ All Members Reinforced
PC	ABS Plastic-clad Aluminum
PF	ABS Plastic w/ Foam-filled Insulation
PH	ABS Plastic w/ Horizontal Members Reinforced
PI	ABS Plastic w/ Reinforcement - Interlock
PL	ABS Plastic
PP	ABS Plastic w/ Reinforcement - Partial
PV	ABS Plastic w/ Vertical Members Reinforced
PW	ABS Plastic-clad Wood
ST	Steel
VA	Vinyl w/ All Members Reinforced
VC	Vinyl-clad Aluminum
VF	Vinyl w/ Foam-filled Insulation
VH	Vinyl w/ Horizontal Members Reinforced
VI	Vinyl w/ Reinforcement - Interlock
VP	Vinyl w/ Reinforcement - Partial
VV	Vinyl w/ Vertical Members Reinforced
VW	Vinyl-clad Wood
VY	Vinyl
WA	Aluminum / Wood composite
WD	Wood
WV	Vinyl / Wood composite
WF	Fiberglass/Wood Combination
WC	Composite/Wood Composite (Shaped vinyl/wood composite members)
CW	Copper Clad Wood
CO	Vinyl/Wood Composite Material

DOOR DETAILS	
N	Not Applicable
CODE	Door Type
EM	Embossed
FL	Flush
LF	Full Lite
LH	1/2 - Lite
LQ	1/4 - Lite
LT	3/4 - Lite
RP	Raised Panel
CODE	Skin
AL	Aluminum
FG	Fiberglass
GS	Galvanized Steel
ST	Steel
WD	Wood
VY	Vinyl
CODE	Panel
FG	Fiberglass
PL	Plastic
WP	Wood - Plywood
WS	Wood - Solid
CODE	Sub-Structure
GS	Galvanized Steel
ST	Steel
WD	Wood
VY	Vinyl
CODE	Core Fill
CH	Cellular - Honeycomb
EP	Expanded Polystyrene
PI	Polyisocyanurate
PU	Polyurethane
WP	Wood - Plywood
WS	Wood - Solid
XP	Extruded Polystyrene

CODE	Spacer Types (See sealant)
A1	Aluminum
A2	Aluminum (Thermally-broken)
A3	Aluminum-reinforced Polymer
A4	Aluminum / Wood
A5	Aluminum-reinforced Butyl (Swiggle)
A6	Aluminum / Foam / Aluminum
A7	Aluminum U-shaped
A8	Aluminum-Butyl (Corrugated) (Duraseal)
ER	EPDM Reinforced Butyl
FG	Fiberglass
GL	Glass
OF	Organic Foam
P1	Duralite
PU	Polyurethane Foam
SU	Stainless Steel, U-shaped
CU	Coated Steel, U-shaped (Intercept)
S2	Steel (Thermally-broken)
S3	Steel / Foam / Steel
S5	Steel-reinforced Butyl
S6	Steel U-channel w/ Thermal Cap
SS	Stainless Steel
CS	Coated Steel
TP	Thermo-plastic
WD	Wood
ZE	Elastomeric Silicone Foam
ZF	Silicone Foam
ZS	Silicone / Steel
N	Not Applicable
TS	Thermo-plastic w/ stainless steel substrate

CODE	Tint Codes
AZ	Azurlite
BL	Blue
BZ	Bronze
CL	Clear
EV	Evergreen
GD	Gold
GR	Green
GY	Gray
LE	Low 'e' Coating
OT	Other (use comment field)
RC	Solar or Reflective Coating
RG	Roller Shades between glazing
RS	Silver (reflective coating)
SF	Suspended Polyester Film
SR	Silver
BG	Blinds between the Glazing
DV	Dynamic Glazing-Variable
DY	Dynamic Glazing-NonVariable

CODE	Gap Fill Codes
AIR	Air
AR2	Argon/Krypton Mixture
AR3	Argon / Krypton / Air
ARG	Argon/Air
CO2	Carbon Dioxide
KRY	Krypton/Air
SF6	Sulfur Hexafluoride
XE2	Xenon/Krypton/Air
XE3	Xenon/Argon/Air
XEN	Xenon/Air
N	Not Applicable

CODE	Spacer Sealant
D	Dual Seal Spacer System
S	Single Seal Spacer System

CODE	Grid Description
N	No Muntins
G	Grids between glass
S	Simulated Divided Lites
T	True Muntins

CODE	Grid Size Codes
	Blank for no grids
0.75	Grids < 1"
1.5	Grids >= 1"

CODE	Thermal Breaks
F	Foam
U	Urethane
V	Vinyl
FB	Fiberglass
O	Other
AB	ABS
NE	Neoprene
AI	Air
N	Not Applicable
P	Polyamide

Appendix B: Drawings

T962-1



Architectural Testing

Test sample complies with these details.
Deviations are noted.

Report# A4283
Date 10/20/16 Tech RPM

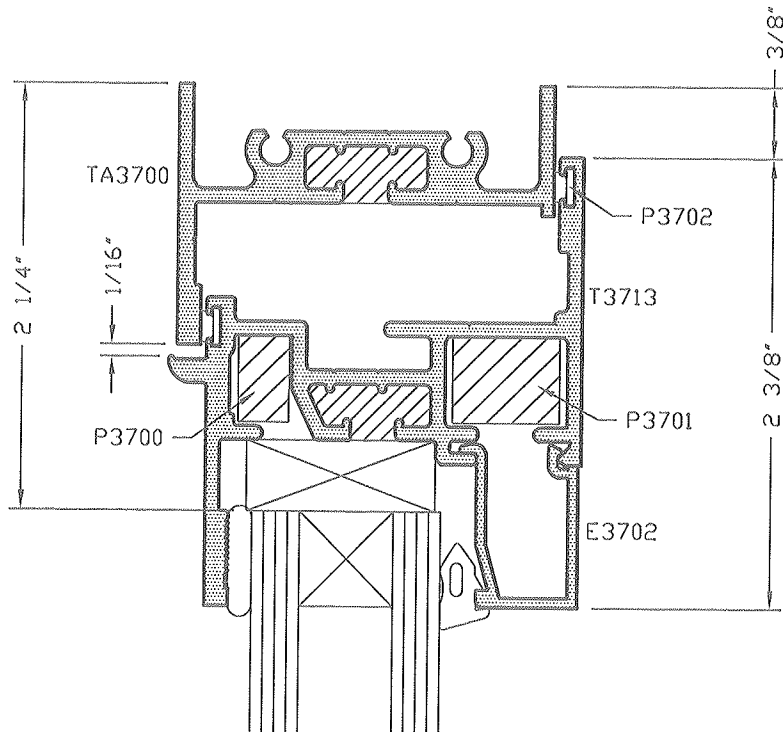

TUBELITE®
 STOREFRONT, CURTAINWALL & ENTRANCES
 DEPENDABLE

HW3700 HOPPER VENT WINDOW
 THERMAL PERFORMANCE TEST
 HEAD DETAIL

DRAWN BY JEM	DRWG DATE 10/08/10	APPV'D BY	DATE APPV'D
DRWG SCALE 1"=1"	PRODUCT CODE 120	T962-1	REV

T962-2



Architectural Testing

Test sample complies with these details.
Deviations are noted.

Report# A4783
Date 10/20/10 Tech EFM

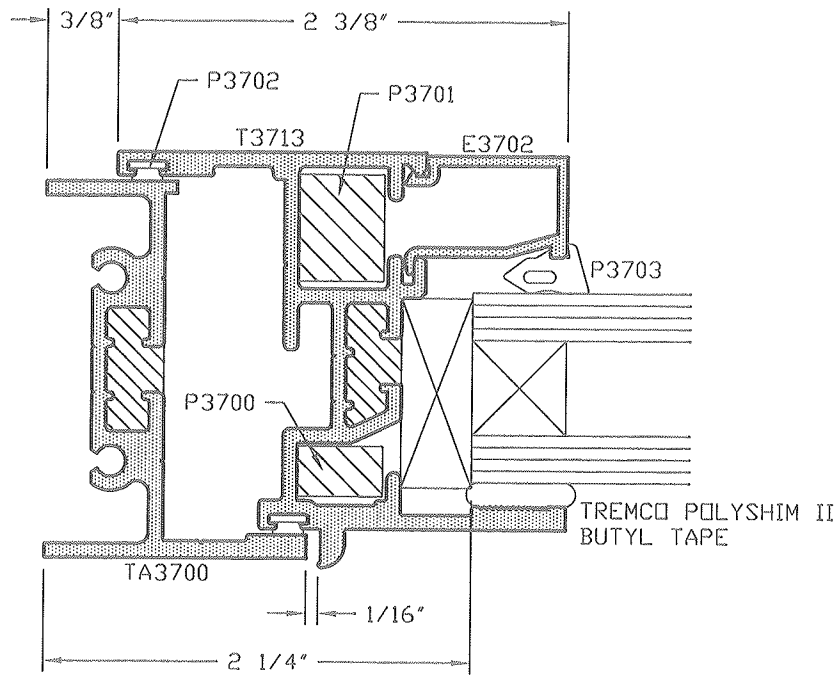

TUBELITE®
STOREFRONT, CURTAINWALL & ENTRANCES
DEPENDABLE

HW3700 HOPPER VENT WINDOW
THERMAL PERFORMANCE TEST
JAMB DETAIL

DRAWN BY JEM	DRVG DATE 10/08/10	APPV'D BY	DATE APPV'D	REV
DRVG SCALE 1"=1"	PRODUCT CODE 120	T962-2		

T962-3



Test sample complies with these details.
Deviations are noted.

Report# A4083
Date 10/20/10 Tech RPM

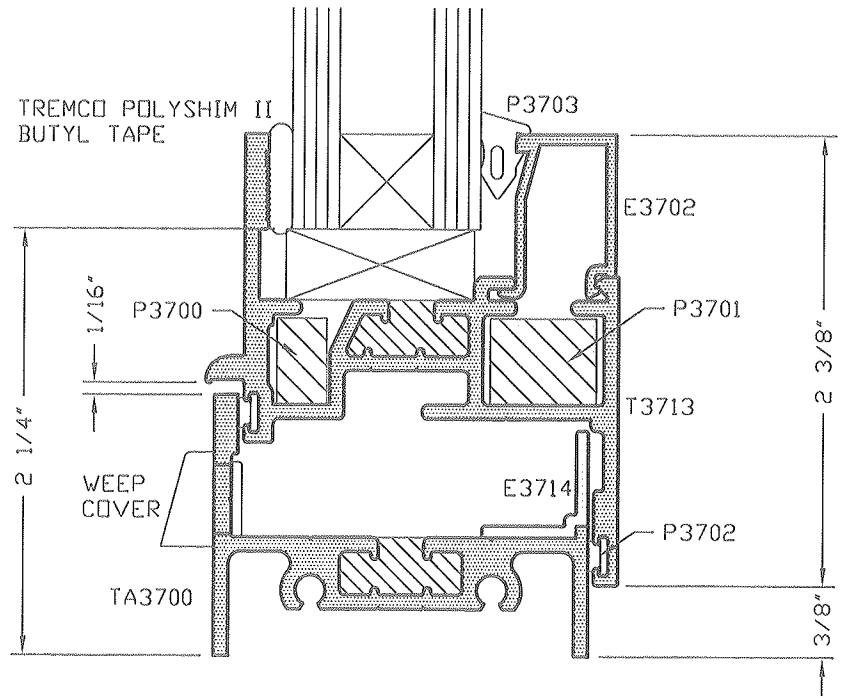

TUBELITE[®]
STOREFRONT, CURTAINWALL & ENTRANCES
DEPENDABLE

HW3700 HOPPER VENT WINDOW
THERMAL PERFORMANCE TEST
SILL DETAIL

DRAWN BY JEM	DRWG DATE 10/08/10	APPV'D BY	DATE APPV'D
DRWG SCALE 1"=1"	PRODUCT CODE 120	T962-3	
			REV

E3702

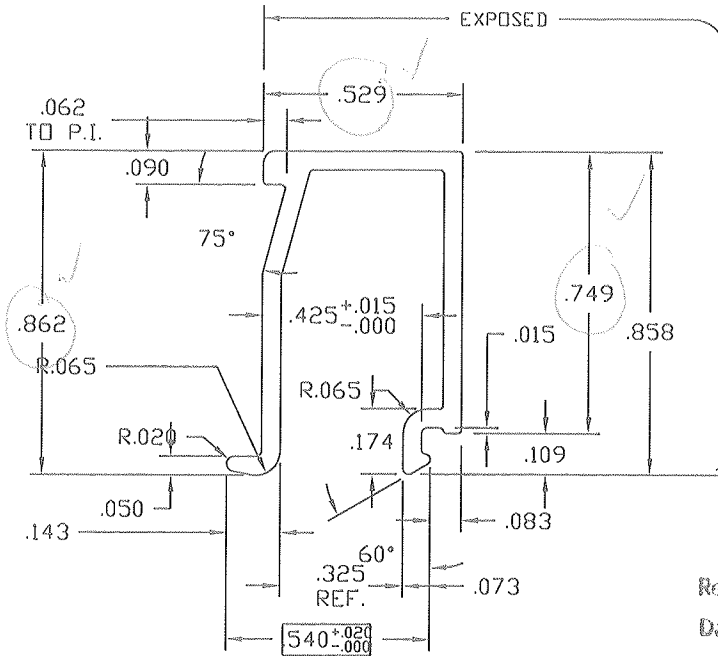

Architectural Testing

Test sample complies with these details.
Deviations are noted.

Report# 14283
Date 10/20/10 Tech RPm

TWO TIMES SCALE

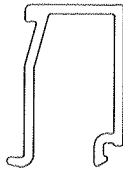

FULL SCALE

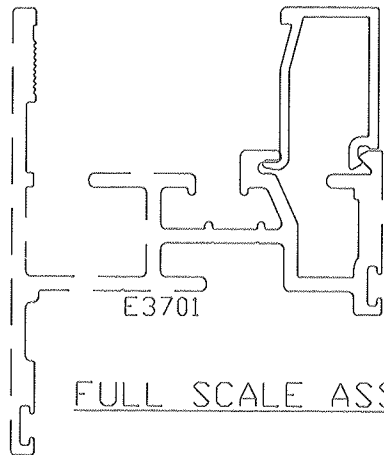

FULL SCALE ASSEMBLY

MATES WITH E3701

© 2006 TUBELITE INC. ALL RIGHTS RESERVED

ALUMINUM ASSOCIATION STANDARD TOLERANCES APPLY UNLESS NOTED

ALL UNSPECIFIED RADII .015

* INDICATES .031 RADIUS

□ DENOTES CRITICAL DIMENSION

ALL DIES PROPERTY OF TUBELITE

TUBELITE®

DEPENDABLE

LEADERS IN ECO-EFFICIENT STOREFRONT, CURTAINWALL AND ENTRANCE SYSTEMS

3056 WALKER RIDGE NW, SUITE G
WALKER, MICHIGAN 49544

WALL THK. .050	SECTION CLASS S	MAT'L 6063-T5	RATIO 464:1
PERIMETER OUT (TOTAL) 4.737	AREA .119	WGT/FT .140	
FACTOR 34	CIRCLE SIZE 1.043	INFILL VOLUME N/A	

RXX .215	SXX .020	IXX .006	CXX .351
RYY .286	SYX .026	IYY .010	CYY .490

GLASS STOP FOR 1" GLASS
VENT WINDOWS

DRAWN BY CRH	DRWG DATE 08/17/00	APPV'D BY	DATE APPV'D
DWG SCALE NOTED	PRODUCT CODE 120	E3702	
			REV

REV	DATE	DESCRIPTION	INTL
	08/25/00	RELEASE FOR TOOLING	CRH
	09/15/00	PART NUMBER WAS E9080001	CRH
	02/13/02	PART NUMBER WAS E908A01	SRD

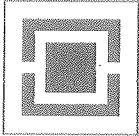

Technoform Informational Bulletin

Structural Testing

Sample complies with these details.
Deviations are noted.

A42-83
replate *tech. plan*

Master Part Chart List

Information Bulletin: 20060102PARTIB

Dated: 09/25/2007

Description: The current Technoform product line is listed in the following document. The products available include a nylon fixed corner key, a steel straight connector, a folding locking corner key and the Box and Wave I-SPACER™ (based on size). Additionally, in this document you will find the methodology for generating the part numbers to be used when ordering any of the products in our inventory.

Spacer Type	Spacer Width			Part Number			
	Fraction	Millimeters	Inches	Spacer	90° Keys	Folding Locking Key	Steel Connector
Box	7/32	5.56	0.2189	IS0732	CK0732F	NA	NA
Box	1/4	6.25	0.2461	IS0104	CK0104F	NA	SC0104S
Box	17/64	6.65	0.2618	IS1764	CK1764F	CK1764(1)	NA
Box	9/32	7.14	0.2811	IS0932	CK0932F	CK0932(1)	NA
Box	5/16	7.84	0.3087	IS0516	CK0516F	NA	SC0516S
Box	21/64	8.33	0.3300	IS2164	CK2164F	CK2164LK(1)	NA
Box	3/8	9.43	0.3713	IS0308	CK0308F	NA	SC0308S
Wave	13/32	10.22	0.4024	IS1332	CK1332F	CK1332LK	SC1332
Wave	7/16	11.01	0.4335	IS0716	CK0716F	NA	SC0716S
Wave	15/32	11.91	0.4689	IS1532	CK1532F	CK1532LK	SC1532S
Wave	1/2	12.60	0.4961	IS0102	CK0102F	NA	SC0102S
Wave	17/32	13.49	0.5272	IS1732	CK1732F	CK1732LK	SC1732S
Wave	9/16	14.19	0.5587	IS0916	CK0916F	NA	SC0916S
Wave	19/32	15.08	0.5937	IS1932	CK1932F	CL1932LK	SC1932S
Wave	5/8	15.87	0.6248	IS0508	CK0508F	NA	SC0508S
Wave	16/25	16.16	0.6362	IS1625	CK1625F	NA	SC1625S
Wave	21/32	16.67	0.6563	IS2132	CK2132F	CK2132LK	SC2132S
Wave	17/25	17.17	0.6760	IS1725	CK1725F	NA	SC1725S
Wave	23/32	18.26	0.7189	IS2332	CK2332F	CK2332LK	SC2332S
Wave	3/4	18.95	0.7461	IS0304	CK0304F	NA	SC0304S
Wave	25/32	19.74	0.7772	IS2532	CK2532F	CK2532LK	SC2532S

Nomenclature Rules: The following outlines the structure used to create part numbers.

Part Build → Product + Size + Type + Color = Product ID

Examples:

I-Spacer IS 1532 LG IS1532LG
 Corner Key CK 1532 F -- CK1532F

Abbreviations:

IS	I-Spacer	LG	Light Gray	F	Fixed	S	Steel
CK	Corner Key	B	Black	LK	Folding Locking	P	Plastic
SC	Straight Connector	W	White				
		BR	Bronze				

Spacer width is the actual width as measured across the top of the thermoplastic blend.

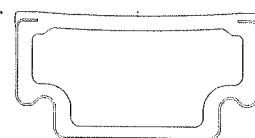

Technoform North America
 1755 Enterprise Parkway, Suite 300
 Helpline: 330.487.6600
 www.technoform.us

TECHNOFORM

GIVE YOUR WINDOWS SPECIAL POWERS™