

**NFRC 102-2010 THERMAL PERFORMANCE  
TEST REPORT**

**Rendered to:**

**TUBELITE, INC.**

**SERIES/MODEL: HW3700 Hopper Window**

**TYPE: Projecting (Awning)**

<b>Summary of Results</b>	
Standardized Thermal Transmittance (U-Factor)	0.46
Unit Size	59" x 23-5/8" (1499 mm x 600 mm) (Model Size)
Layer 1	1/4" PPG Solarban 60 (e=0.035*, #2) Tempered
Gap 1	0.47" Gap, Technoform TGI Spacer (TS-D), 90% Argon-Filled*
Layer 2	1/4" Clear Tempered

Reference must be made to Report No. A4283.01-116-46, dated 10/29/10 for complete test specimen description and data.



Architectural Testing

**NFRC 102-2010 THERMAL PERFORMANCE TEST REPORT**

Rendered to:

TUBELITE, INC.  
4878 Mackinaw Trail  
Reed City, Michigan 49677

Report Number: A4283.01-116-46

Test Date: 10/20/10

Report Date: 10/29/10

Test Record Retention Date: 10/20/14

**Test Sample Identification:**

**Series/Model:** HW3700 Hopper Window

**Type:** Projecting (Awning)

**Overall Size:** 59" x 23-5/8" (1499 mm x 600 mm) (Model Size)

**NFRC Standard Size:** 59.1" x 23.6" (1500 mm wide x 600 mm high)

**Test Sample Submitted by:** Client

**Test Sample Submitted for:**

**Test Procedure:** U-factor tests were performed in a Guarded Hot Box in accordance with NFRC 102-2010, *Procedure for Measuring the Steady-State Thermal Transmittance of Fenestration Systems*.

**Test Results Summary:**

Standardized U-factor ( $U_{st}$ ): 0.46 Btu/hr·ft<sup>2</sup>·F CTS Method

**Test Sample Description:**

<b>CONSTRUCTION</b>	<b>Frame</b>	<b>Vent</b>
Size (in.)	59" x 23-5/8"	58-3/8" x 23"
Daylight Opening (in.)	N/A	53-1/2" x 18-1/4"
<b>CORNERS</b>	Coped	Mitered
Fasteners	Screws	Keys & Stakes
Sealant	Yes	Yes
<b>MATERIAL</b>	AT (0.22")	AT (0.24")
Color Exterior	Black	Black
Finish Exterior	Anodized	Anodized
Color Interior	Black	Black
Finish Interior	Anodized	Anodized
<b>GLAZING METHOD</b>	N/A	Interior

**Glazing Information:**

<b>Layer 1</b>	1/4" PPG Solarban 60 (e=0.035*, #2) Tempered
<b>Gap 1</b>	0.47" Gap, Technoform TGI Spacer (TS-D), 90% Argon-Filled*
<b>Layer 2</b>	1/4" Clear Tempered
<b>Gas Fill Method</b>	Single-Probe Method*

*\*Stated per Client/Manufacturer*

*N/A Non-Applicable*

*See Description Table Abbreviations*

**Test Sample Description:** (Continued)

<b>COMPONENTS</b>		
<b>Type</b>	<b>Quantity</b>	<b>Location</b>
<b>WEATHERSTRIP</b>		
Flexible hollow bulb gasket	2 rows	Vent perimeter
<b>HARDWARE</b>		
1/4 Turn lever lock handles	2	Top rail
Metal keepers	2	Head
Multi-arm hinge	2	Jambs/stiles
<b>DRAINAGE</b>		
(1.13" x 0.25") weepslot with cover	2	Sill face

## Thermal Transmittance (U-factor)

### Measured Test Data

#### Heat Flows

1. Total Measured Input into Metering Box ( $Q_{total}$ )	469.20 Btu/hr
2. Surround Panel Heat Flow ( $Q_{sp}$ )	125.37 Btu/hr
3. Surround Panel Thickness	4.00 inches
4. Surround Panel Conductance	0.0444 Btu/hr-ft <sup>2</sup> -F
5. Metering Box Wall Heat Flow ( $Q_{mb}$ )	19.31 Btu/hr
6. EMF vs Heat Flow Equation (equivalent information)	0.0362*EMF + -0.020
7. Flanking Loss Heat Flow ( $Q_{fl}$ )	9.40 Btu/hr
8. Net Specimen Heat Loss ( $Q_s$ )	315.13 Btu/hr

#### Areas

1. Test Specimen Projected Area ( $A_s$ )	9.68 ft <sup>2</sup>
2. Test Specimen Interior Total (3-D) Surface Area ( $A_h$ )	11.08 ft <sup>2</sup>
3. Test Specimen Exterior Total (3-D) Surface Area ( $A_c$ )	10.51 ft <sup>2</sup>
4. Metering Box Opening Area ( $A_{mb}$ )	52.94 ft <sup>2</sup>
5. Metering Box Baffle Area ( $A_{b1}$ )	46.97 ft <sup>2</sup>
6. Surround Panel Interior Exposed Area ( $A_{sp}$ )	43.26 ft <sup>2</sup>

#### Test Conditions

1. Average Metering Room Air Temperature ( $t_h$ )	69.80 F
2. Average Cold Side Air Temperature ( $t_c$ )	-0.40 F
3. Average Guard/Environmental Air Temperature	71.25 F
4. Metering Room Average Relative Humidity	14.67 %
5. Metering Room Maximum Relative Humidity	15.64 %
6. Metering Room Minimum Relative Humidity	13.69 %
7. Measured Cold Side Wind Velocity (Perpendicular Flow)	17.07 mph
8. Measured Static Pressure Difference Across Test Specimen	0.00" ± 0.04"H <sub>2</sub> O

#### Results

1. Thermal Transmittance of Test Specimen ( $U_s$ )	0.46 Btu/hr-ft <sup>2</sup> -F
2. Standardized Thermal Transmittance of Test Specimen ( $U_{st}$ )	0.46 Btu/hr-ft <sup>2</sup> -F

## Thermal Transmittance (U-factor)

### Calculated Test Data

#### CTS Method

1. Warm Side Emittance of Glass ( $e_i$ )	0.84
2. Cold Side Emittance of Glass	0.84
3. Warm Side Frame Emittance	0.80
4. Cold Side Frame Emittance	0.80
5. Warm Side Sash/Panel/Vent Emittance	0.80
6. Cold Side Sash/Panel/Vent Emittance	0.80
7. Warm Side Baffle Emittance ( $e_{bi}$ )	0.92
8. Equivalent Warm Side Surface Temperature	46.58 F
9. Equivalent Cold Side Surface Temperature	5.62 F
10. Warm Side Baffle Surface Temperature	69.41 F
11. Measured Warm Side Surface Conductance ( $h_h$ )	1.40 Btu/hr·ft <sup>2</sup> ·F
12. Measured Cold Side Surface Conductance ( $h_c$ )	5.41 Btu/hr·ft <sup>2</sup> ·F
13. Test Specimen Thermal Conductance ( $C_s$ )	0.79 Btu/hr·ft <sup>2</sup> ·F
14. Convection Coefficient ( $K_c$ )	0.31 Btu/(hr·ft <sup>2</sup> ·F <sup>1.25</sup> )
15. Radiative Test Specimen Heat Flow ( $Q_{ri}$ )	164.37 Btu/hr
16. Conductive Test Specimen Heat Flow ( $Q_{ci}$ )	150.75 Btu/hr
17. Radiative Heat Flux of Test Specimen ( $q_{ri}$ )	16.98 Btu/hr·ft <sup>2</sup> ·F
18. Convective Heat Flux of Test Specimen ( $q_{ci}$ )	15.57 Btu/hr·ft <sup>2</sup> ·F
19. Standardized Warm Side Surface Conductance ( $h_{sth}$ )	1.36 Btu/hr·ft <sup>2</sup> ·F
20. Standardized Cold Side Surface Conductance ( $h_{stc}$ )	5.28 Btu/hr·ft <sup>2</sup> ·F
21. Standardized Thermal Transmittance ( $U_{st}$ )	0.46 Btu/hr·ft <sup>2</sup> ·F

#### Test Duration

1. The environmental systems were started at 06:57 hours, 10/19/10.
2. The test parameters were considered stable for two consecutive four hour test periods from 09:03 hours, 10/20/10 to 17:03 hours, 10/20/10.
3. The thermal performance test results were derived from 13:03 hours, 10/20/10 to 17:03 hours, 10/20/10.

The reported Standardized Thermal Transmittance ( $U_{st}$ ) was determined using CTS Method, per Section 8.2(A) of NFRC 102.

**Glazing Deflection (in):**

	Vent
Edge Gap Width	0.47
Estimated center gap width upon receipt of specimen in laboratory (after stabilization)	0.47
Center gap width at laboratory ambient conditions on day of testing	0.47
Center gap width at test conditions	0.41

*Glass collapse determined using a digital glass and air space meter*

The sample was inspected for the formation of frost or condensation, which may influence the surface temperature measurements. The sample showed no evidence of condensation/frost at the conclusion of the test.

A calibration of the Architectural Testing Inc. 'thermal test chamber' (ICN 000001) in York, Pennsylvania was conducted in May 2010 in accordance with Architectural Testing Inc. calibration procedure.

"This test method does not include procedures to determine the heat flow due to either air movement through the specimen or solar radiation effects. As a consequence, the thermal transmittance results obtained do not reflect performances which may be expected from field installations due to not accounting for solar radiation, air leakage effects, and the thermal bridge effects that may occur due to the specific design and construction of the fenestration system opening. Therefore, it should be recognized that the thermal transmittance results obtained from this test method are for ideal laboratory conditions and should only be used for fenestration product comparisons and as input to thermal performance analyses which also include solar, air leakage and thermal bridge effects."

"Ratings included in this report are for submittal to an NFRC-licensed IA for certification purposes and are not meant to be used for labeling purposes. Only those values identified on a valid Certification Authorization Report (CAR) are to be used for labeling purposes."

The test sample was installed in a vertical orientation, the exterior of the specimen was exposed to the cold side. The direction of heat transfer was from the interior (warm side) to the exterior (cold side) of the specimen.

ANSI/NCSL Z540-2-1997 type B uncertainty for this test was 4.75%.

Detailed drawings, data sheets, representative samples of test specimens, a copy of this report, or other pertinent project documentation will be retained by Architectural Testing, Inc. for a period of four years from the original test date. At the end of this retention period such materials shall be discarded without notice and the service life of this report by Architectural Testing will expire. Results obtained are tested values and were secured by using the designated test methods. This report does not constitute certification of this product nor an opinion or endorsement by this laboratory. Ratings included in this report are for submittal to an NFRC licensed IA for certification purposes and are not meant to be used for labeling purposes. Only those values identified on a valid Certification Authorization Report (CAR) are to be used for labeling purposes. It is the exclusive property of the client so named herein and relates only to the specimen(s) tested. This report may not be reproduced, except in full, without the written approval of Architectural Testing, Inc.

For ARCHITECTURAL TESTING, INC.

Tested By:

Reviewed By:

---

Ryan P. Moser  
Technician

---

Shon W. Einsig  
Senior Technician  
Individual-In-Responsible-Charge

RPM:ake  
A4283.01-116-46

Attachments (pages): This report is complete only when all attachments listed are included.

- Appendix-A: Description Table Abbreviations (1)
- Appendix-B: CTS Calibration Data (1)
- Appendix-C: Surround Panel Wiring Diagram (1)
- Appendix-D: Baffle Wiring Diagram (1)
- Appendix-E: Submittal Form and Drawings (6)

### Revision Log

<u>Rev. #</u>	<u>Date</u>	<u>Page(s)</u>	<u>Revision(s)</u>
.01R0	10/29/10	All	Original Report Issue. Work requested by Steve Wilkening of Tubelite, Inc.

**Appendix A: Description Table Abbreviations**

CODE	Frame / Sash Types
AI	Aluminum w/ Vinyl Inserts (Caps)
AL	Aluminum
AP	Aluminum w/ Thermal Breaks - Partial
AS	Aluminum w/ Steel Reinforcement
AT	Aluminum w/ Thermal Breaks - All Members (> 0.21")
AU	Aluminum Thermally Improved - All Members (0.062" - 0.209")
AV	Aluminum / Vinyl Composite
AW	Aluminum-clad Wood
FG	Fiberglass
PA	ABS Plastic w/ All Members Reinforced
PC	ABS Plastic-clad Aluminum
PF	ABS Plastic w/ Foam-filled Insulation
PH	ABS Plastic w/ Horizontal Members Reinforced
PI	ABS Plastic w/ Reinforcement - Interlock
PL	ABS Plastic
PP	ABS Plastic w/ Reinforcement - Partial
PV	ABS Plastic w/ Vertical Members Reinforced
PW	ABS Plastic-clad Wood
ST	Steel
VA	Vinyl w/ All Members Reinforced
VC	Vinyl-clad Aluminum
VF	Vinyl w/ Foam-filled Insulation
VH	Vinyl w/ Horizontal Members Reinforced
VI	Vinyl w/ Reinforcement - Interlock
VP	Vinyl w/ Reinforcement - Partial
VV	Vinyl w/ Vertical Members Reinforced
VW	Vinyl-clad Wood
VY	Vinyl
WA	Aluminum / Wood composite
WD	Wood
WV	Vinyl / Wood composite
WF	Fiberglass/Wood Combination
WC	Composite/Wood Composite (Shaped vinyl/wood composite members)
CW	Copper Clad Wood
CO	Vinyl/Wood Composite Material

DOOR DETAILS	
N	Not Applicable
CODE	Door Type
EM	Embossed
FL	Flush
LF	Full Lite
LH	1/2 - Lite
LQ	1/4 - Lite
LT	3/4 - Lite
RP	Raised Panel
CODE	Skin
AL	Aluminum
FG	Fiberglass
GS	Galvanized Steel
ST	Steel
WD	Wood
VY	Vinyl
CODE	Panel
FG	Fiberglass
PL	Plastic
WP	Wood - Plywood
WS	Wood - Solid
CODE	Sub-Structure
GS	Galvanized Steel
ST	Steel
WD	Wood
VY	Vinyl
CODE	Core Fill
CH	Cellular - Honeycomb
EP	Expanded Polystyrene
PI	Polyisocyanurate
PU	Polyurethane
WP	Wood - Plywood
WS	Wood - Solid
XP	Extruded Polystyrene

CODE	Spacer Types (See sealant)
A1	Aluminum
A2	Aluminum (Thermally-broken)
A3	Aluminum-reinforced Polymer
A4	Aluminum / Wood
A5	Aluminum-reinforced Butyl (Swiggle)
A6	Aluminum / Foam / Aluminum
A7	Aluminum U-shaped
A8	Aluminum-Butyl (Corrugated) (Duraseal)
ER	EPDM Reinforced Butyl
FG	Fiberglass
GL	Glass
OF	Organic Foam
P1	Duralite
PU	Polyurethane Foam
SU	Stainless Steel, U-shaped
CU	Coated Steel, U-shaped (Intercept)
S2	Steel (Thermally-broken)
S3	Steel / Foam / Steel
S5	Steel-reinforced Butyl
S6	Steel U-channel w/ Thermal Cap
SS	Stainless Steel
CS	Coated Steel
TP	Thermo-plastic
WD	Wood
ZE	Elastomeric Silicone Foam
ZF	Silicone Foam
ZS	Silicone / Steel
N	Not Applicable
TS	Thermo-plastic w/ stainless steel substrate

CODE	Tint Codes
AZ	Azurlite
BL	Blue
BZ	Bronze
CL	Clear
EV	Evergreen
GD	Gold
GR	Green
GY	Gray
LE	Low 'e' Coating
OT	Other (use comment field)
RC	Solar or Reflective Coating
RG	Roller Shades between glazing
RS	Silver (reflective coating)
SF	Suspended Polyester Film
SR	Silver
BG	Blinds between the Glazing
DV	Dynamic Glazing-Variable
DY	Dynamic Glazing-NonVariable

CODE	Gap Fill Codes
AIR	Air
AR2	Argon/Krypton Mixture
AR3	Argon / Krypton / Air
ARG	Argon/Air
CO2	Carbon Dioxide
KRY	Krypton/Air
SF6	Sulfur Hexafluoride
XE2	Xenon/Krypton/Air
XE3	Xenon/Argon/Air
XEN	Xenon/Air
N	Not Applicable

CODE	Spacer Sealant
D	Dual Seal Spacer System
S	Single Seal Spacer System

CODE	Grid Description
N	No Muntins
G	Grids between glass
S	Simulated Divided Lites
T	True Muntins

CODE	Grid Size Codes
	Blank for no grids
0.75	Grids < 1"
1.5	Grids >= 1"

CODE	Thermal Breaks
F	Foam
U	Urethane
V	Vinyl
FB	Fiberglass
O	Other
AB	ABS
NE	Neoprene
AI	Air
N	Not Applicable
P	Polyamide

**Appendix B: CTS Calibration Data**

1. CTS Test Date	06/09/10
2. CTS Size	9.69 ft <sup>2</sup>
3. Glass Conductance	6.93 Btu/hr·ft <sup>2</sup> ·F
4. CTS Core Conductance	0.20 Btu/hr·ft <sup>2</sup> ·F
5. Warm Side Air Temperature	69.80 F
6. Cold Side Air Temperature	-0.38 F
7. Warm Side Average Surface Temperature	54.84 F
8. Cold Side Average Surface Temperature	3.35 F
9. Convection Coefficient (K <sub>c</sub> )	0.30 Btu/(hr·ft <sup>2</sup> ·F <sup>1.25</sup> )
10. Measured Cold Side Surface Conductance (h <sub>c</sub> )	5.39 Btu/hr·ft <sup>2</sup> ·F
11. Measured Thermal Transmittance	0.31 Btu/hr·ft <sup>2</sup> ·F

### Appendix C: Surround Panel Wiring Diagram

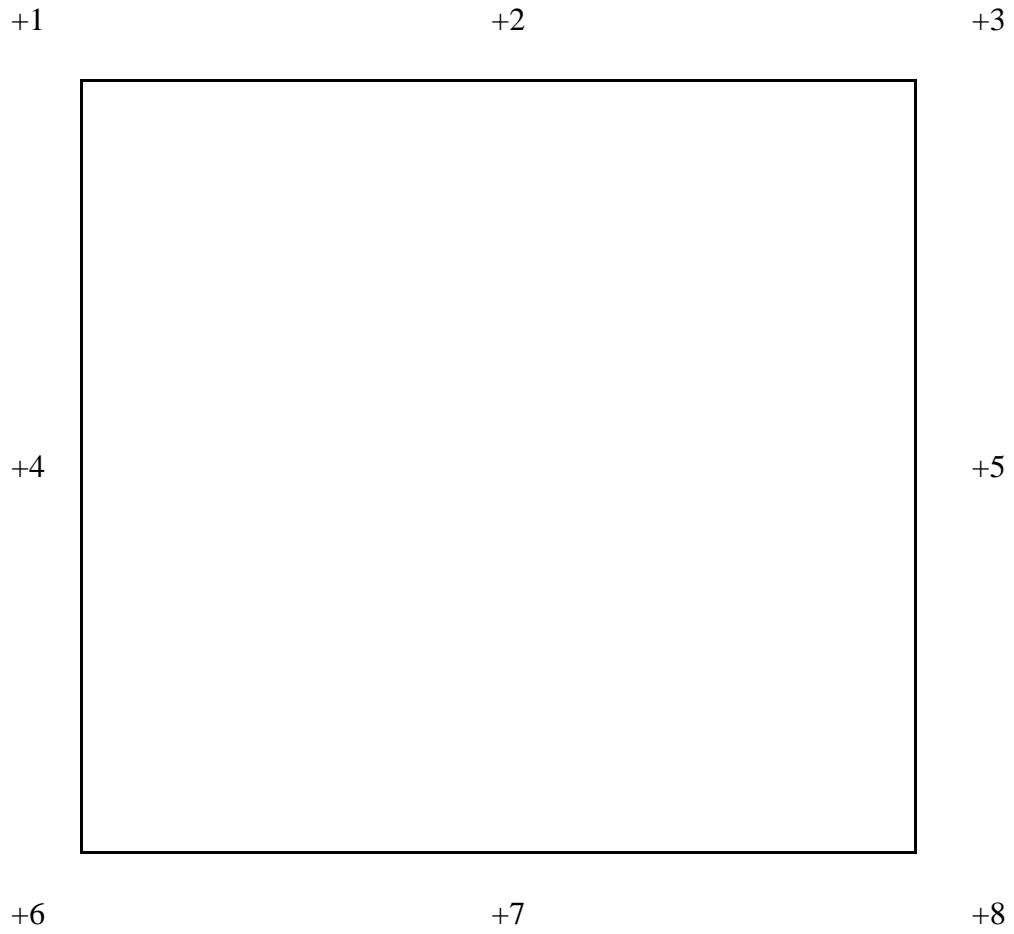

### Appendix D: Baffle Wiring Diagram

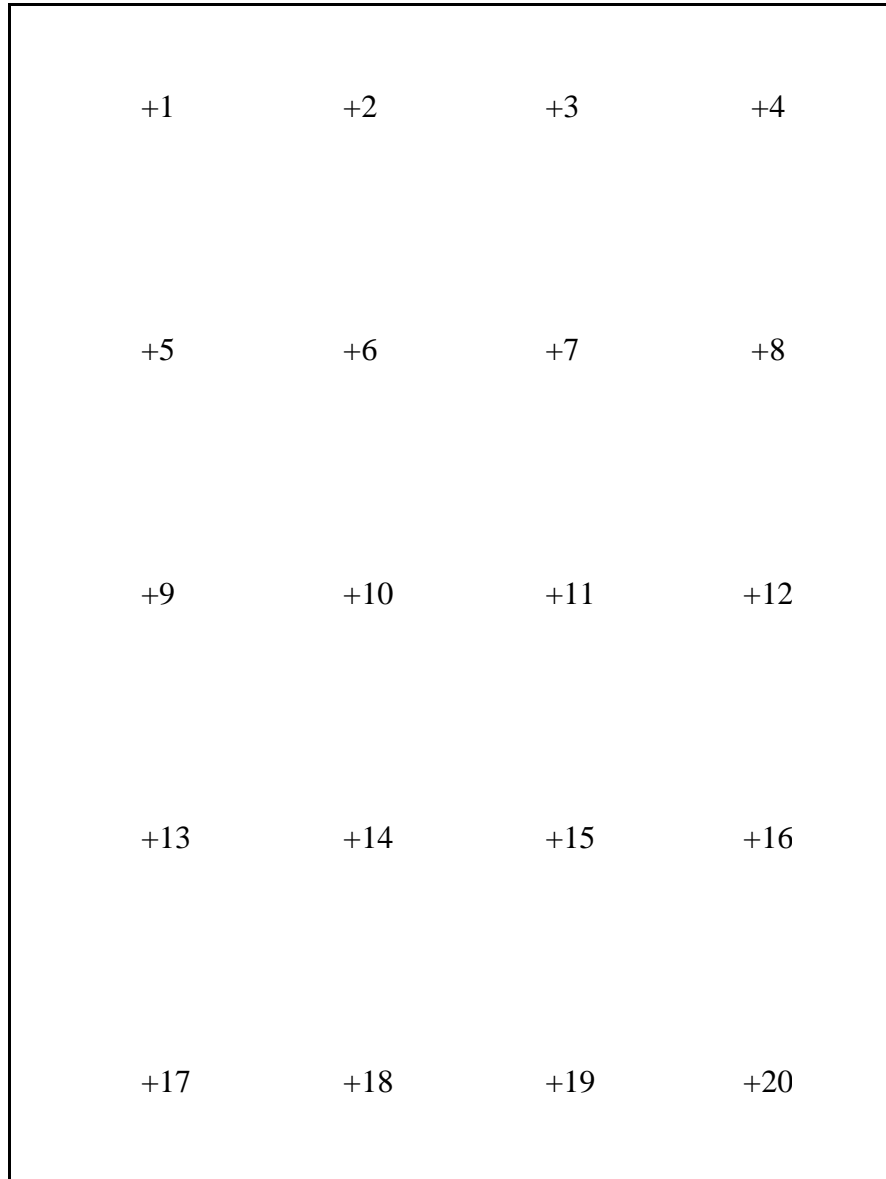

**Appendix E: Submittal Form and Drawings**

T962-1



# Architectural Testing

Test sample complies with these details.  
Deviations are noted.

Report# A4283

Date: 10/20/16 Tech RPM

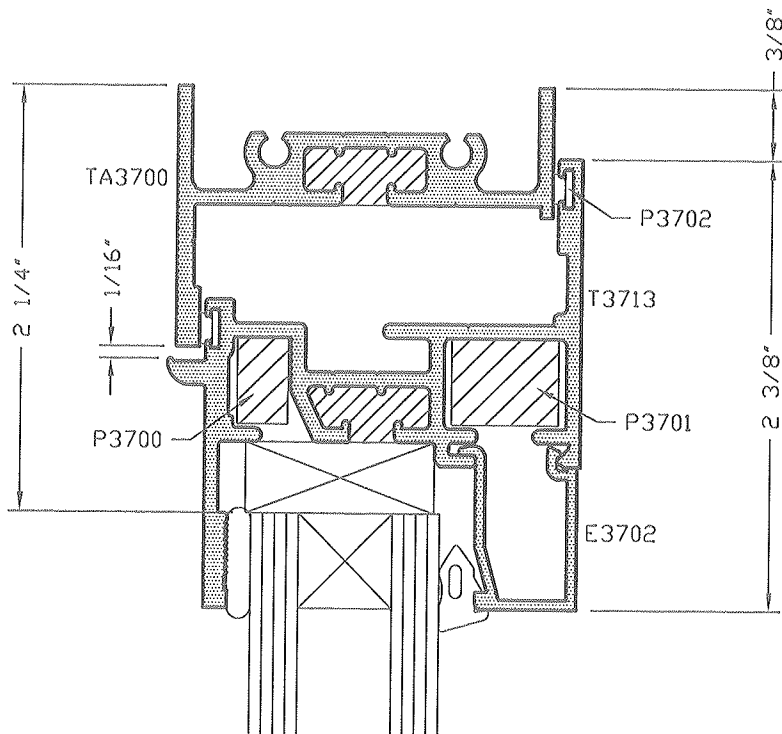

# TUBELITE®

STOREFRONT, CURTAINWALL & ENTRANCES

DEPENDABLE

HW3700 HOPPER VENT WINDOW  
THERMAL PERFORMANCE TEST  
HEAD DETAIL

DRAWN BY JEM	DRWG DATE 10/08/10	APPV'D BY	DATE APPV'D
DRWG SCALE 1"=1"	PRODUCT CODE 120	T962-1	REV

T962-2



# Architectural Testing

Test sample complies with these details.  
Deviations are noted.

Report# A4783  
Date 10/20/10 Tech EFM

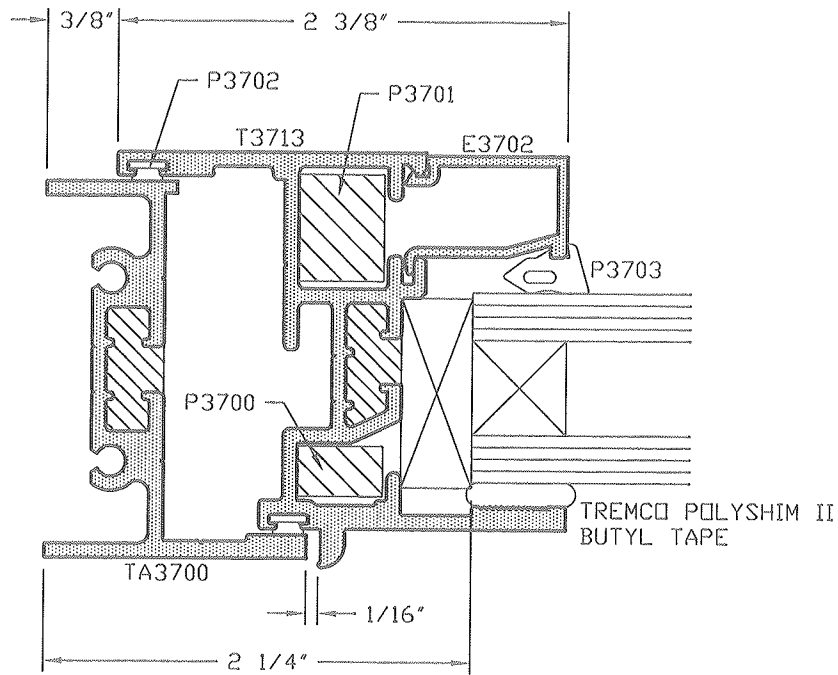

**TUBELITE®**  
 STOREFRONT, CURTAINWALL & ENTRANCES  
 DEPENDABLE

HW3700 HOPPER VENT WINDOW  
 THERMAL PERFORMANCE TEST  
 JAMB DETAIL

DRAWN BY JEM	DRVG DATE 10/08/10	APPV'D BY	DATE APPV'D	REV
DRVG SCALE 1"=1"	PRODUCT CODE 120	T962-2		

T962-3



Test sample complies with these details.  
Deviations are noted.

Report# A4083  
Date 10/20/10 Tech RPM

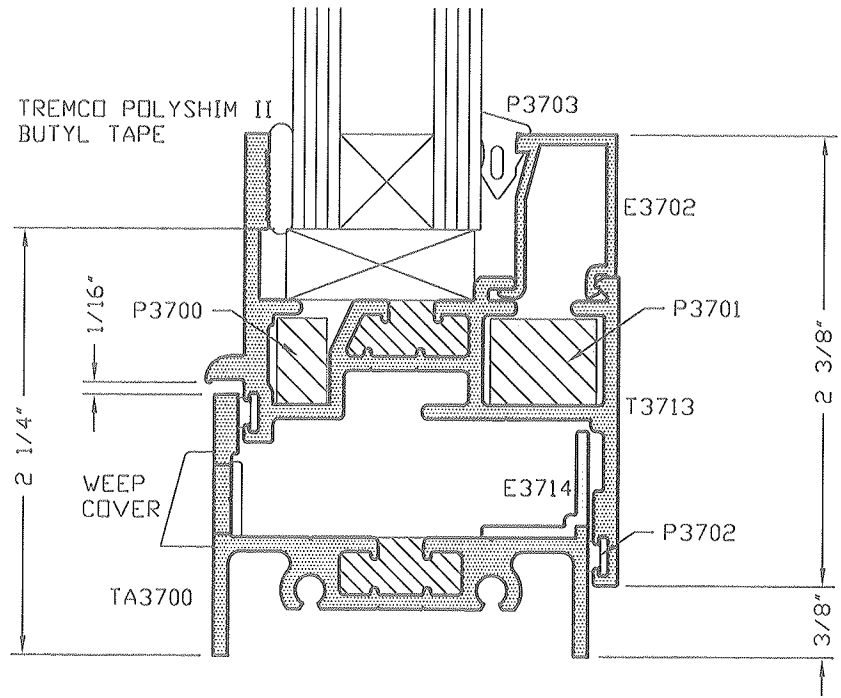

**TUBELITE**®  
STOREFRONT, CURTAINWALL & ENTRANCES  
*DEPENDABLE*

HW3700 HOPPER VENT WINDOW  
THERMAL PERFORMANCE TEST  
SILL DETAIL

DRAWN BY JEM	DRWG DATE 10/08/10	APPV'D BY	DATE APPV'D
DRWG SCALE 1"=1"	PRODUCT CODE 120	T962-3	
			REV

E3702

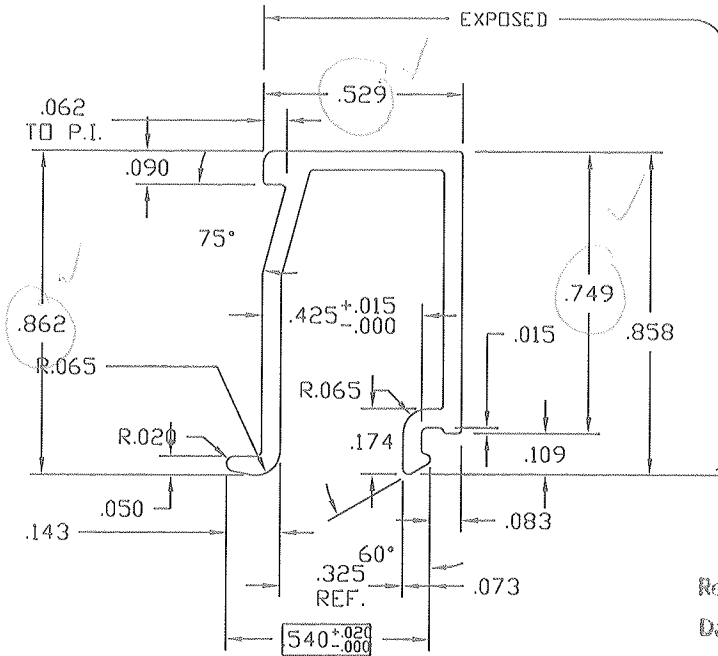

**Architectural Testing**

Test sample complies with these details. Deviations are noted.

Report# 14283  
 Date 10/20/10 Tech RPm

TWO TIMES SCALE

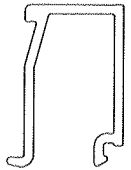

FULL SCALE

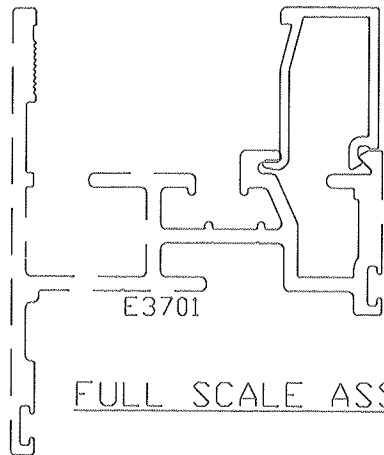

FULL SCALE ASSEMBLY

MATES WITH E3701

© 2006 TUBELITE INC. ALL RIGHTS RESERVED

ALUMINUM ASSOCIATION STANDARD TOLERANCES APPLY UNLESS NOTED

ALL UNSPECIFIED RADII .015

\* INDICATES .031 RADIUS

□ DENOTES CRITICAL DIMENSION

ALL DIES PROPERTY OF TUBELITE

**TUBELITE®**

DEPENDABLE

LEADERS IN ECO-EFFICIENT STOREFRONT, CURTAINWALL AND ENTRANCE SYSTEMS

3056 WALKER RIDGE NW, SUITE G  
 WALKER, MICHIGAN 49544

WALL THK. .050	SECTION CLASS S	MAT'L 6063-T5	RATIO 464:1
PERIMETER OUT (TOTAL) 4.737	AREA .119	WGT/FT .140	
FACTOR 34	CIRCLE SIZE 1.043	INFILL VOLUME N/A	

RXX .215	SXX .020	IXX .006	CXX .351
RYY .286	SYX .026	IYY .010	CYY .490

GLASS STOP FOR 1" GLASS VENT WINDOWS

REV	DATE	DESCRIPTION	INTL
	08/25/00	RELEASE FOR TOOLING	CRH
	09/15/00	PART NUMBER WAS E9080001	CRH
	02/13/02	PART NUMBER WAS E908A01	SRD

DRAWN BY CRH	DRWG DATE 08/17/00	APPV'D BY	DATE APPV'D
DWG SCALE NOTED	PRODUCT CODE 120	E3702	
			REV



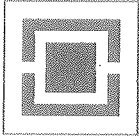

# Technoform Informational Bulletin

Structural Testing

Sample complies with these details.  
Deviations are noted.

*A42-83*  
*replate* *tech. plan*

## Master Part Chart List

Information Bulletin: 20060102PARTIB

Dated: 09/25/2007

**Description:** The current Technoform product line is listed in the following document. The products available include a nylon fixed corner key, a steel straight connector, a folding locking corner key and the Box and Wave I-SPACER™ (based on size). Additionally, in this document you will find the methodology for generating the part numbers to be used when ordering any of the products in our inventory.

Spacer Type	Spacer Width			Part Number			
	Fraction	Millimeters	Inches	Spacer	90° Keys	Folding Locking Key	Steel Connector
Box	7/32	5.56	0.2189	IS0732	CK0732F	NA	NA
Box	1/4	6.25	0.2461	IS0104	CK0104F	NA	SC0104S
Box	17/64	6.65	0.2618	IS1764	CK1764F	CK1764(1)	NA
Box	9/32	7.14	0.2811	IS0932	CK0932F	CK0932(1)	NA
Box	5/16	7.84	0.3087	IS0516	CK0516F	NA	SC0516S
Box	21/64	8.33	0.3300	IS2164	CK2164F	CK2164LK(1)	NA
Box	3/8	9.43	0.3713	IS0308	CK0308F	NA	SC0308S
Wave	13/32	10.22	0.4024	IS1332	CK1332F	CK1332LK	SC1332
Wave	7/16	11.01	0.4335	IS0716	CK0716F	NA	SC0716S
Wave	15/32	11.91	0.4689	IS1532	CK1532F	CK1532LK	SC1532S
Wave	1/2	12.60	0.4961	IS0102	CK0102F	NA	SC0102S
Wave	17/32	13.49	0.5272	IS1732	CK1732F	CK1732LK	SC1732S
Wave	9/16	14.19	0.5587	IS0916	CK0916F	NA	SC0916S
Wave	19/32	15.08	0.5937	IS1932	CK1932F	CL1932LK	SC1932S
Wave	5/8	15.87	0.6248	IS0508	CK0508F	NA	SC0508S
Wave	16/25	16.16	0.6362	IS1625	CK1625F	NA	SC1625S
Wave	21/32	16.67	0.6563	IS2132	CK2132F	CK2132LK	SC2132S
Wave	17/25	17.17	0.6760	IS1725	CK1725F	NA	SC1725S
Wave	23/32	18.26	0.7189	IS2332	CK2332F	CK2332LK	SC2332S
Wave	3/4	18.95	0.7461	IS0304	CK0304F	NA	SC0304S
Wave	25/32	19.74	0.7772	IS2532	CK2532F	CK2532LK	SC2532S

**Nomenclature Rules:** The following outlines the structure used to create part numbers.

Part Build → Product + Size + Type + Color = Product ID

Examples:

I-Spacer                    IS                    1532                    LG                    IS1532LG  
 Corner Key                CK                    1532                    F                    --                    CK1532F

Abbreviations:

IS	I-Spacer	LG	Light Gray	F	Fixed	S	Steel
CK	Corner Key	B	Black	LK	Folding Locking	P	Plastic
SC	Straight Connector	W	White				
		BR	Bronze				

Spacer width is the actual width as measured across the top of the thermoplastic blend.

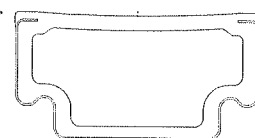

Technoform North America  
 1755 Enterprise Parkway, Suite 300  
 Helpline: 330.487.6600  
 www.technoform.us

**TECHNOFORM**

GIVE YOUR WINDOWS SPECIAL POWERS™