

14650 Series Flush Glaze

Fabrication and Installation Instructions

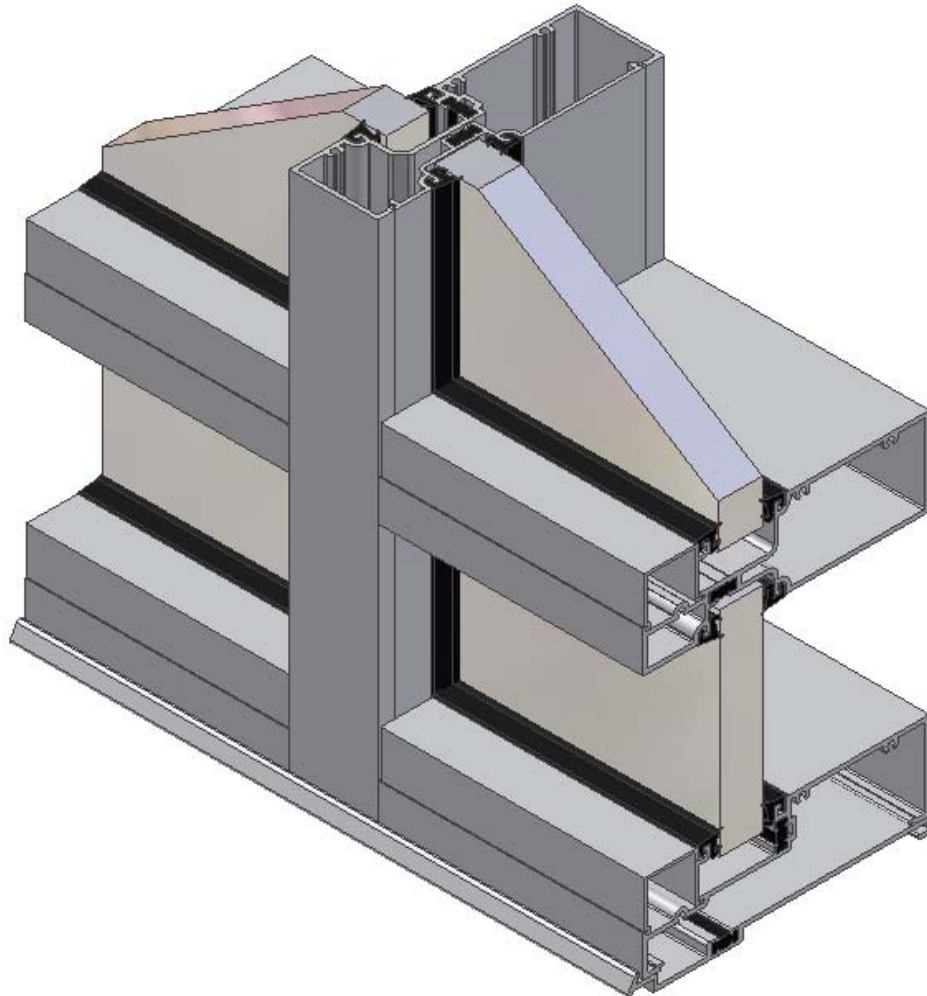

TUBELITE®
STOREFRONT, CURTAINWALL & ENTRANCES
DEPENDABLE

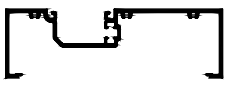
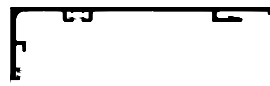
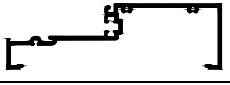



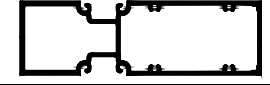
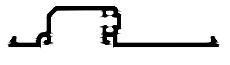

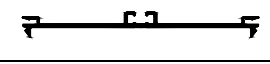



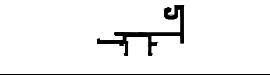
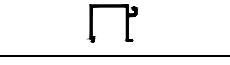

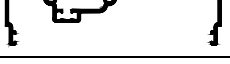

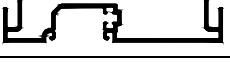
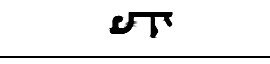

Table of Contents

GENERAL CONSTRUCTION NOTES.....	3
EXTRUDED ALUMINUM PARTS.....	4
ACCESSORIES	5
OVERVIEW	6
FRAME FABRICATION	10
Step #1: Determine frame size	10
Determine frame width.....	10
Determine frame height.....	11
Step #2: Cut sill flashing to size and drill weep holes	11
Step #3: Cut vertical framing members to size.....	12
Step #4: Cut horizontal framing members to size	12
Step #5 (Screw Spline Assembly): Drill holes in vertical framing members	12
Step #5 (Shear Block Assembly): Drill holes in vertical framing members	15
Step #6 (shear-block assembly): Drill holes in horizontal framing members.....	18
Step #7 (if needed): Cut glazing adapters to length	20
FRAME INSTALLATION.....	21
Step #1 (if needed): Splice the flashing where required per final distribution dwgs.....	21
Step #2: Seal and anchor the flashing	22
Step #3 (shear block assembly): Seal and secure frame clips to verticals.....	23
Step #4 (shear block assembly): Attach horizontals to frame clips.....	25
Step #3 (Screw Spline Assembly): Attach horizontals to verticals.....	26
Step #4: (Screw Spline Assembly): Install assembled units	27
Step #5: Attach frame to masonry	28
Step #6: Install P1135 water diverters.....	29
GLAZING INSTALLATION.....	30
Step #1: Cut and install the interior gaskets.....	30
Step #2: Install the glass	31
Step #3: Cut and install the exterior gaskets.....	31
Step #4: Seal perimeter of installation	31















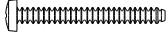
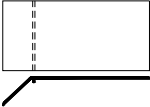

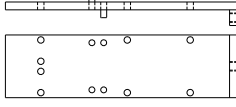
GENERAL CONSTRUCTION NOTES

1. These instructions cover typical product application, fabrication, installation and standard conditions and are general in nature. They provide useful guidelines, but the final distribution drawings may include additional details specific to this project. Any conflict or discrepancies must be prior to execution.
2. Materials stored at the job site must be kept in a safe place removed from possible damage by other trades. Stack with adequate separation so materials will not rub together, and store off the ground. Cardboard or paper wrapped materials must be kept dry. Check arriving materials for quantity and keep record of where various materials are stored.
3. All field welding must be done in accordance with AISC guidelines. All aluminum and glass should be shielded from field welding to avoid damage from weld splatter. Results will be unsightly and may be structurally unsound. Advise general contractor and other trades accordingly.
4. Coordinate protection of installed work with general contractor and/or other trades.
5. Coordinate sequence of other trades which affect framing installation with the general contractor (e.g. fire proofing, back up walls, partitions, ceiling, mechanical ducts, convectors, etc.).
6. General contractor should furnish and guarantee bench marks, offset lines and opening dimensions. These items should be checked for accuracy before proceeding with erection. Make certain that all adjacent substrate construction is in accordance with the contract documents and/or approved shop drawings. If not, notify the general contractor in writing before proceeding with installation because this could constitute acceptance of adjacent substrate construction by others.
7. Isolate all aluminum to be placed directly in contact with masonry or other incompatible materials, using a heavy coat of zinc chromate or bituminous paint.
8. Sealant selection is the responsibility and option of the erector, installer and/or glazing contractor and must be approved by the sealant manufacturer with regard to application and compatibility for its intended use. All sealants must be used in strict accordance with the manufacturer's instructions and applied only by trained personnel to surfaces that have been properly prepared.
9. Sealant must be compatible with all materials with which they have contact, including other sealant surfaces. Consult sealant manufacturer for recommendations relative to shelf life, compatibility, cleaning of substrate, priming, tooling adhesion, etc.
10. Drainage gutters and weep holes must be kept clean at all times. Tubelite cannot accept responsibility for improper drainage as a result of clogged gutters and weep holes.
11. This product requires clearances at head, sill and jambs to allow for thermal expansion and contraction. Refer to final distribution drawings for joint sizes. Joints smaller than 1/4" may be subject to failure. Consult your sealant supplier.
12. All materials are to be installed plumb, level and true with regard to established bench marks and column center lines established by the general contractor and checked by the erector, installer and/or glazing contractor.
13. Cleaning of exposed aluminum surfaces should be done per AAMA recommendations.

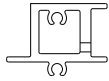
EXTRUDED ALUMINUM PARTS

Shape	Description	Part No.	Shape	Description	Part No.
	Open Back Head/Vertical	E/T14641		Head Receptor	E/T14629
	Open-back Sill/ Intermediate Horizontal	E/T 14640		Interior Snap-in Stop	E14130
	Sill Flashing	T14659		Open-back Door Jamb	E14644
	Snap-in Closure with shallow glass pocket	E/T14642		Door Header	E14624
	Snap-In Closure with Deep Pocket	E/T14632		Door Header	E14625
	Snap-in Closure with shallow glass pocket	E/T14652		Snap-in closure/adapter	E/T14648
	Flat Snap-in Closure	E14653		Tubular Door Jamb	E14621
	Tubular Sill/Horizontal	E/T14643		Transom Sash for 1" Glass	E4013
	Glass Stop	E14104		Glass Stop	E4015
	Expansion Vertical - Male	E/T14646		Door Stop	E4531
	Expansion Vertical - Female	E/T14636		Glazing adapter for 1/4" glass	E-14036
	Glazing adapter for 1/2" glass	E14061			

ACCESSORIES

Shape	Description	Part No.	Shape	Description	Part No.
	Captured Gasket	P2728		End Dam for Sill Flashing	P1154
	Captured Gasket	P487		#10 x 1" Type B Phillips/Hex Head Fastener for Screw Spline connections	S202
	Setting Block	P1132		#10 x 1 3/4" Type B Phillips Pan Head Screw Fastener for clip to horizontal attachment.	S009
	Water Diverter	P1135		Snap-in Filler for open-back anchor points (6" lengths)	P1148
	Pile Weathering	P1098A		Drill Fixture for screw-spline attachment	P1149 Rev. A
	5/16" - 18 threaded swivel pad thumb screw w/ delrin tip for P1149	P1682		Bulb type Gasket for head receptor	P2511
	Sill Flashing Splice Sleeve	P1147		Frame Clip	P1152
	Frame Clip	P1134		Frame Clip	P1141
	Rigid PVC Pocket Filler	P4563		Rigid PVC Pocket Filler	P4553
	Aluminum Pocket Filler	P1768		#12 x 3/4" Phillips flat head	S149

OVERVIEW

Tubelite's 14650 Series Flush Glaze product is available in thermal as well as non-thermal versions.

The illustration below shows the elevation view of a typical 14650 Series installation. The number in the top half of each circle is the number of a figure showing details of the associated system component; the number in the bottom half of each circle gives the page number on which that figure appears.

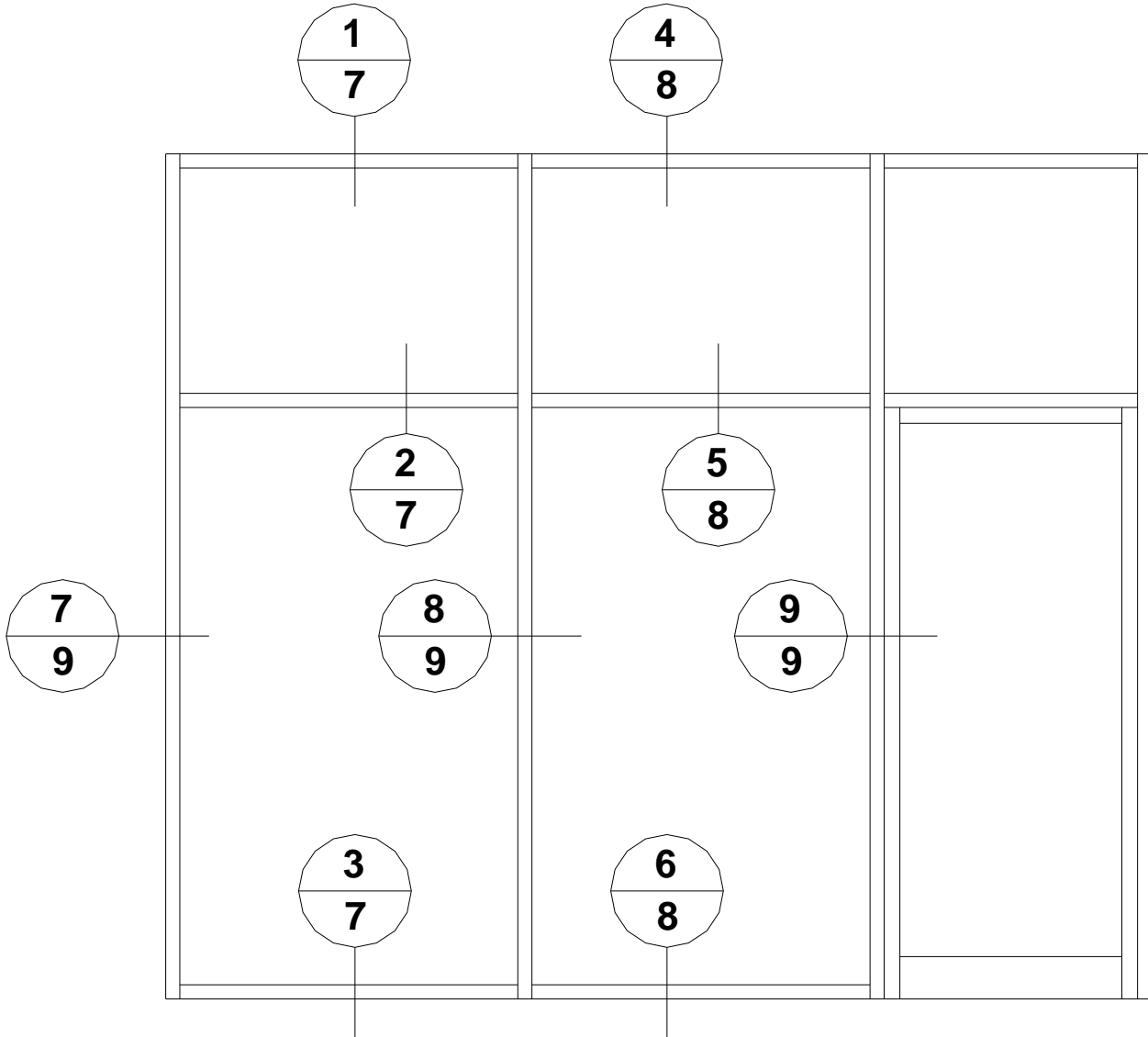

Elevation of a typical 14650 Series installation

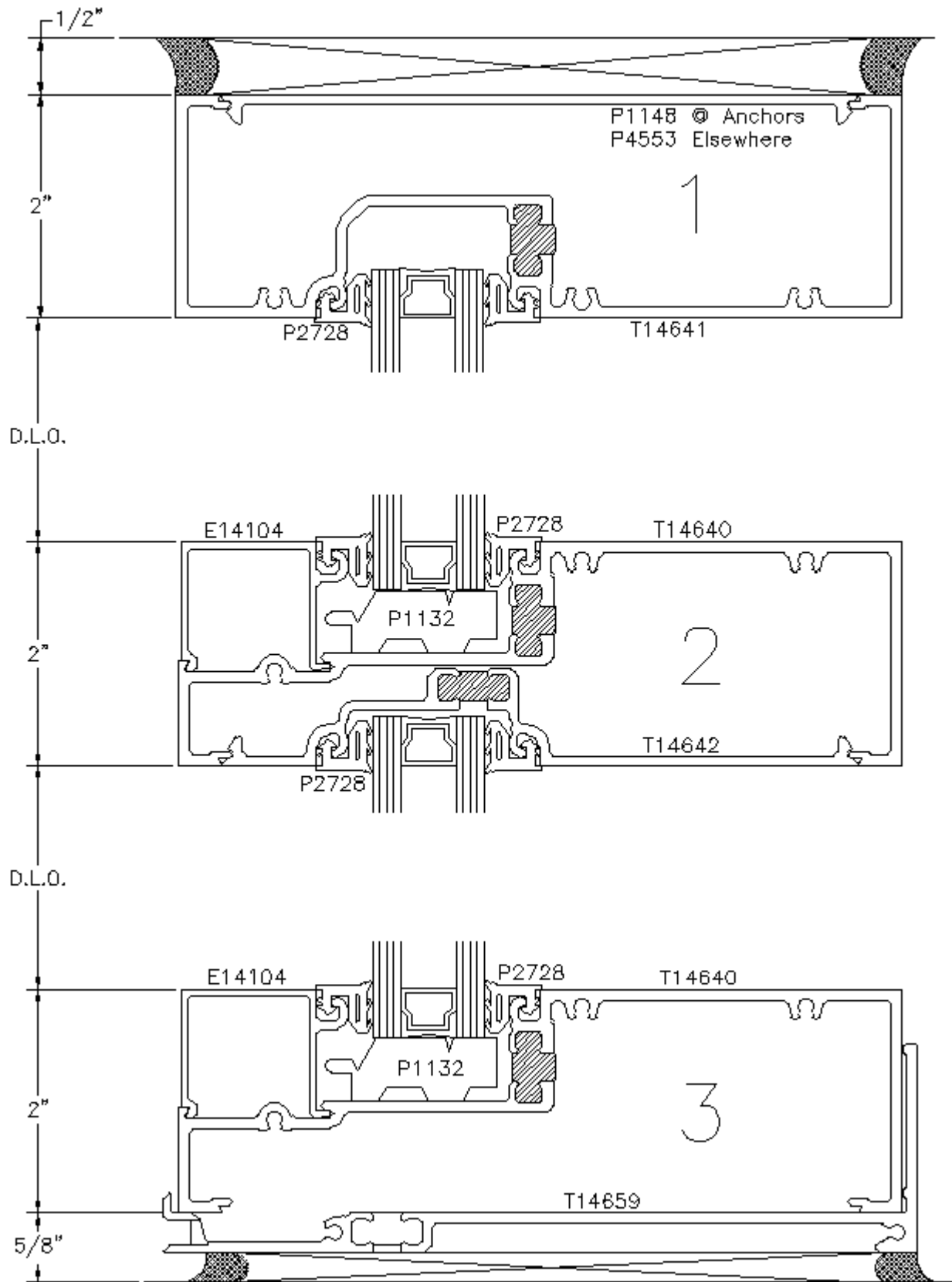

Typical horizontal details

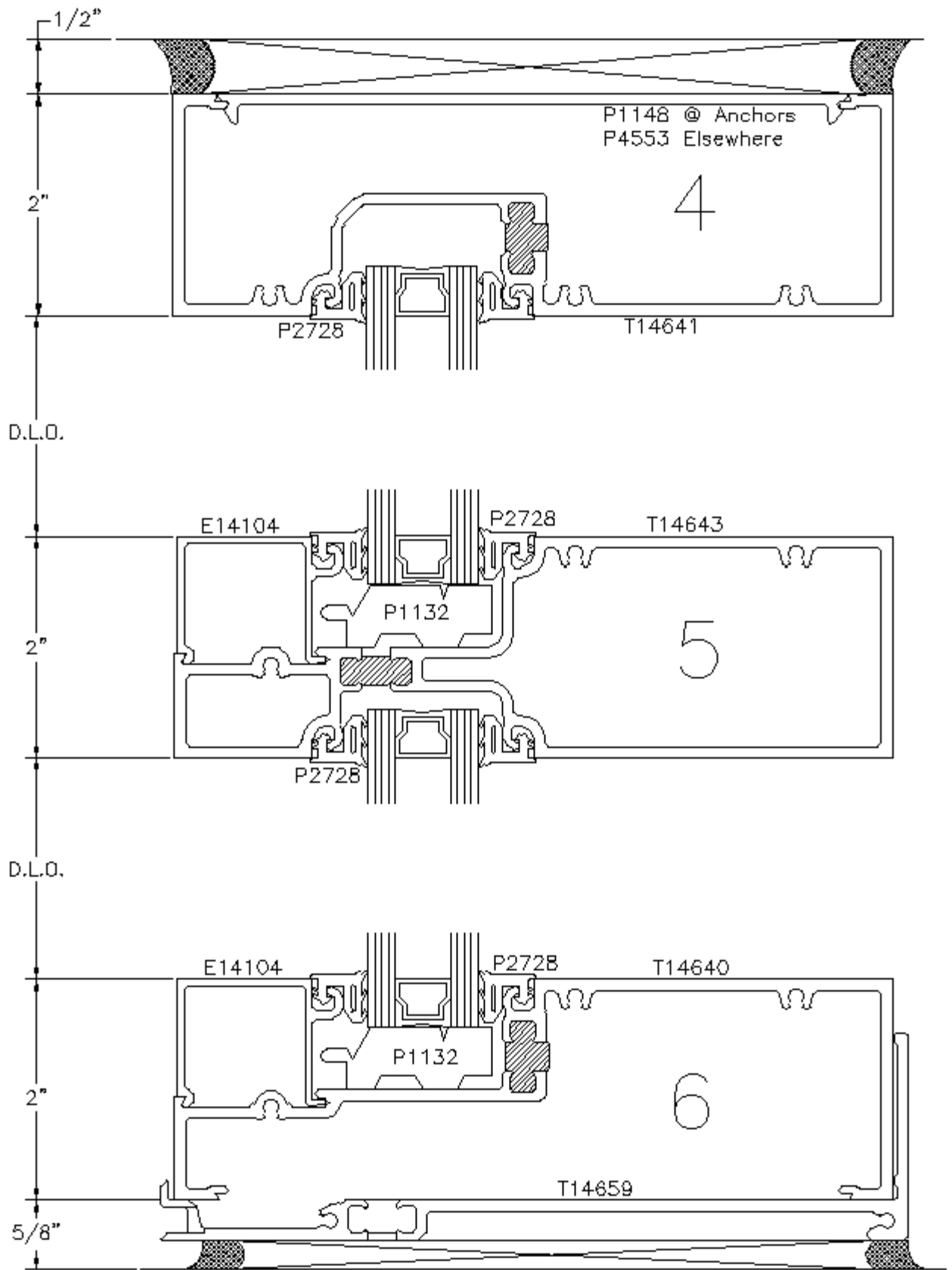

Typical horizontal details

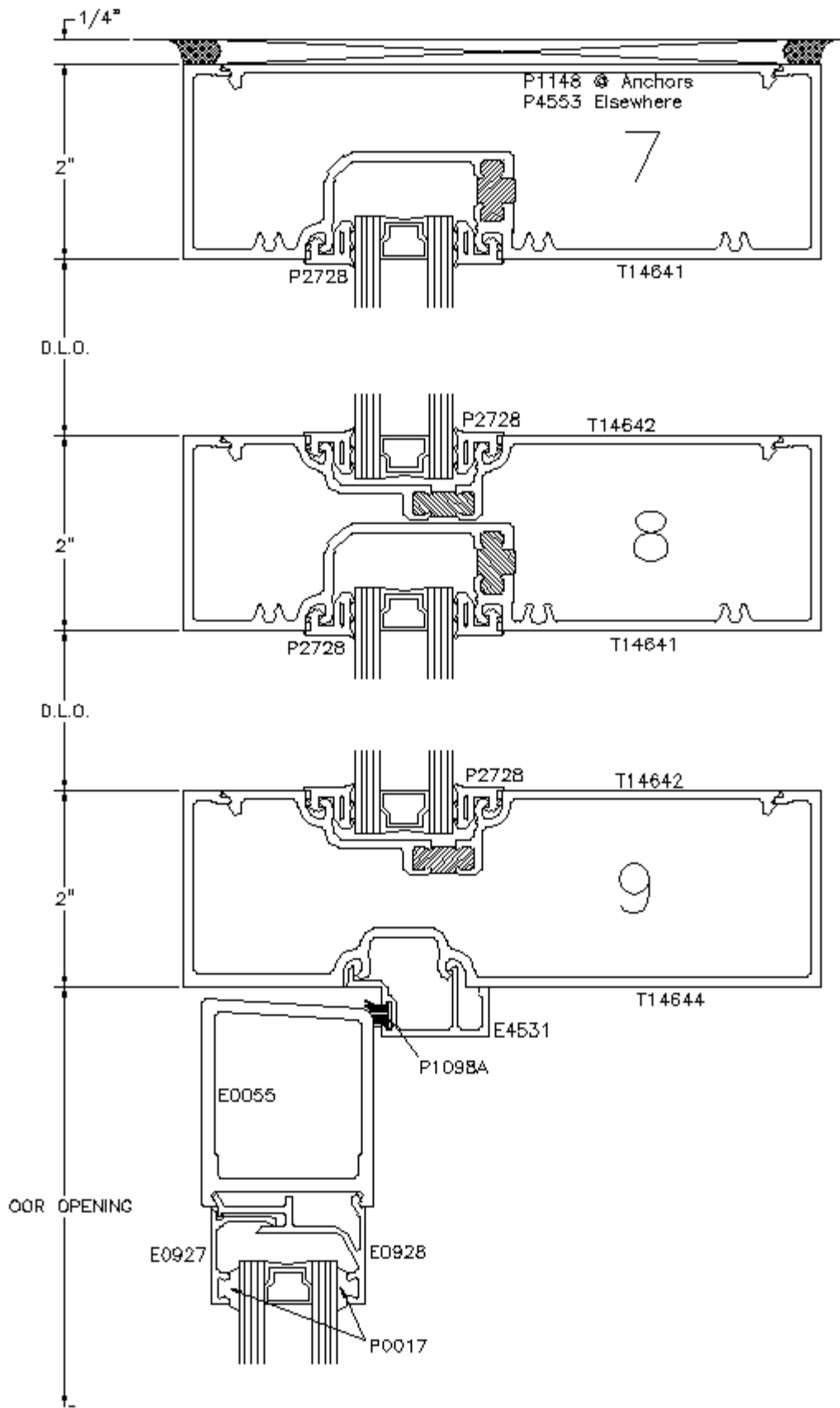

Typical vertical details

FRAME FABRICATION

Step #1: Determine frame size

Determine frame width

Check that the opening is square and plumb at both ends. Units must be installed in a true rectangle.

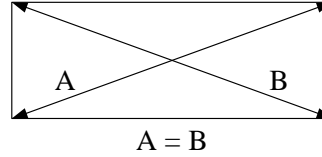

- Measure the width of the masonry opening at the top, middle and bottom.
- Select the smallest dimension measured. To determine the frame width to be used, subtract a minimum of 1/2" from the smallest measured width, to allow a minimum of 1/4" at each jamb for shimming and caulking. Allow a larger clearance if necessary to accommodate building tolerances, an out-of-square opening, and/or anticipated thermal expansion within the unit.

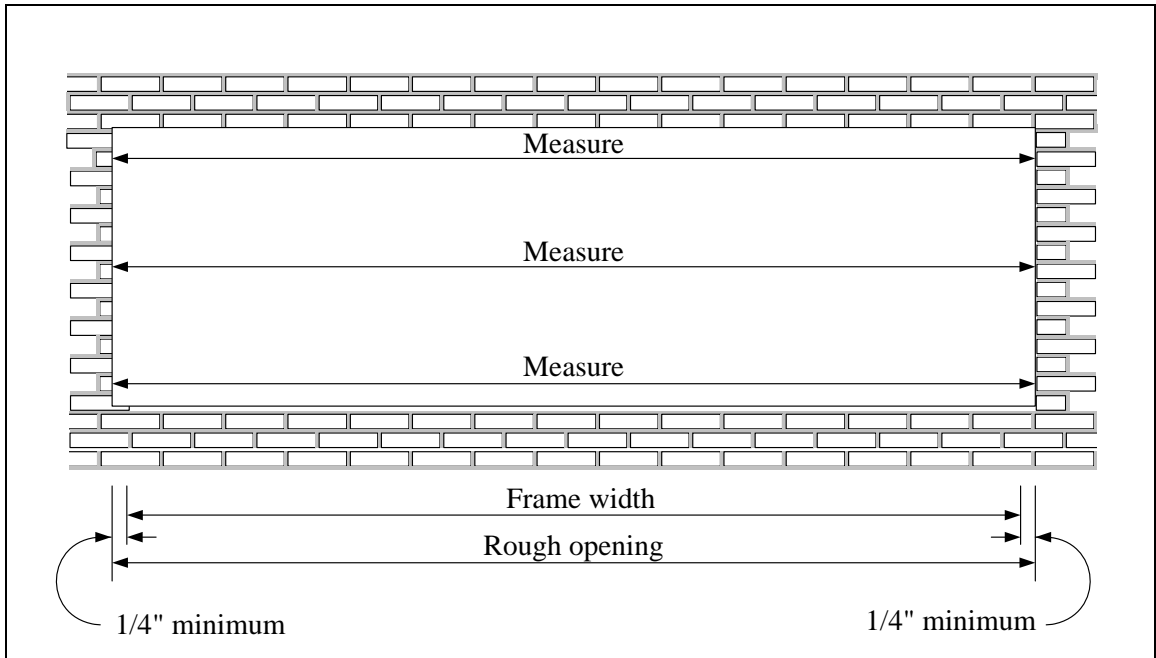

Determine frame height

- Measure the height of the masonry opening in several places along the entire length of the opening.
- To determine the frame height to be used, select the smallest dimension measured and subtract 1 1/8" to allow a minimum of 5/8" at sill and 1/2" at head to accommodate the T14659 sill flashing, shimming and caulking.

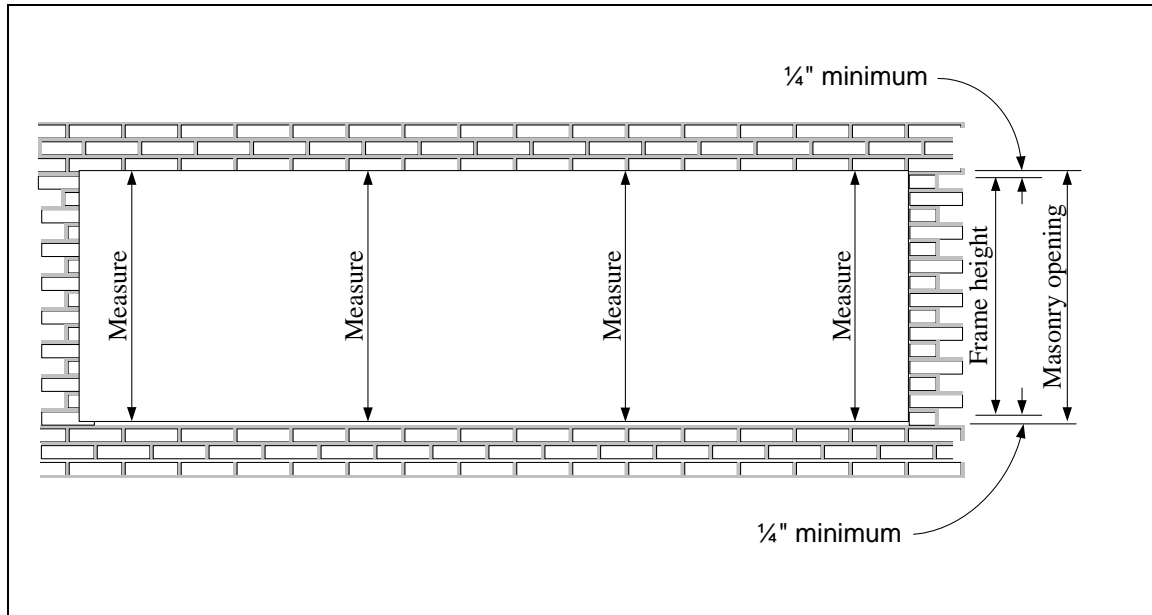

Step #2: Cut sill flashing to size and drill weep holes

- Cut flashing (T14659) to frame width determined in Step #1 above (rough opening minus clearances). If the installation is to include an entrance, the flashing should butt against the back of the door jamb (no clearance).
- Flashing longer than 24' in length must be spliced using part number P-1147. If flashing must be spliced, allow 3/8" to 1/2" for the width of the splice.
- At the quarter points of each light, drill 7/32" diameter holes in the sill flashing, as shown in the illustration on page 12. Install a PTB42 weep baffle in the gutter of the extruded sill flashing behind each weep hole.

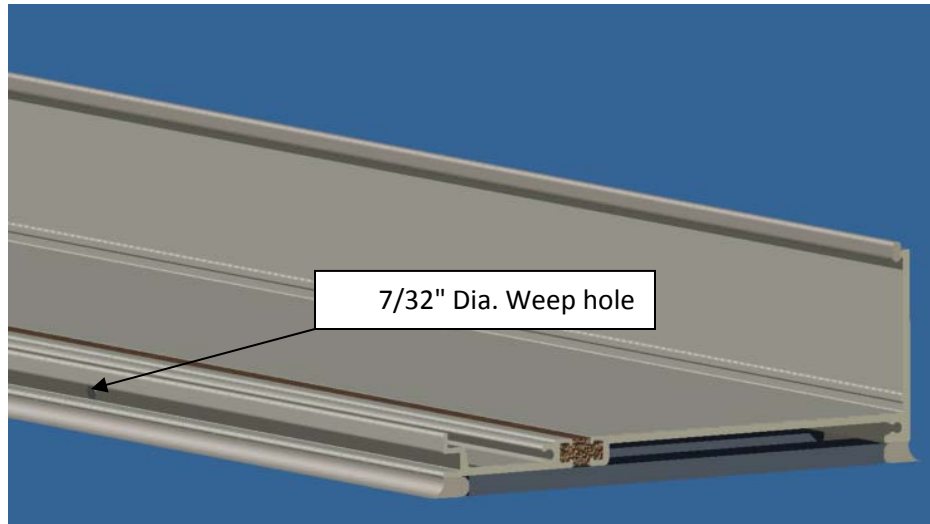

Weep hole in sill flashing

Step #3: Cut vertical framing members to size

- Verticals should be the frame height as determined in Step #1 on page 10 (rough opening height minus clearances).
- As shown in the elevation overview on page 9, vertical framing members run through.

Step #4: Cut horizontal framing members to size

- Cut horizontal framing members to the daylight opening (the distance between verticals).
- For easier installation, cut horizontal glazing beads 1/32" shorter than the horizontal framing member.

Step #5 (Screw Spline Assembly): Drill holes in vertical framing members

In screw-spline assembly, screws are driven through holes in the vertical members, directly into screw splines on the horizontal members. These screws are what support the horizontal members and the glass. The two drawings in this section show where to drill the holes in seven kinds of vertical members so that they line up with the screw splines on the horizontals used with these verticals.

- The screw used for screw-spline assembly is a #10-24 x 1" Type 23 Phillips hex head (S202). To accommodate this type of screw, the holes in the vertical framing members must be .201" in diameter, corresponding to a #7 drill.
- Tubelite offers a drill fixture (P1149) to help find the correct hole locations quickly and accurately.

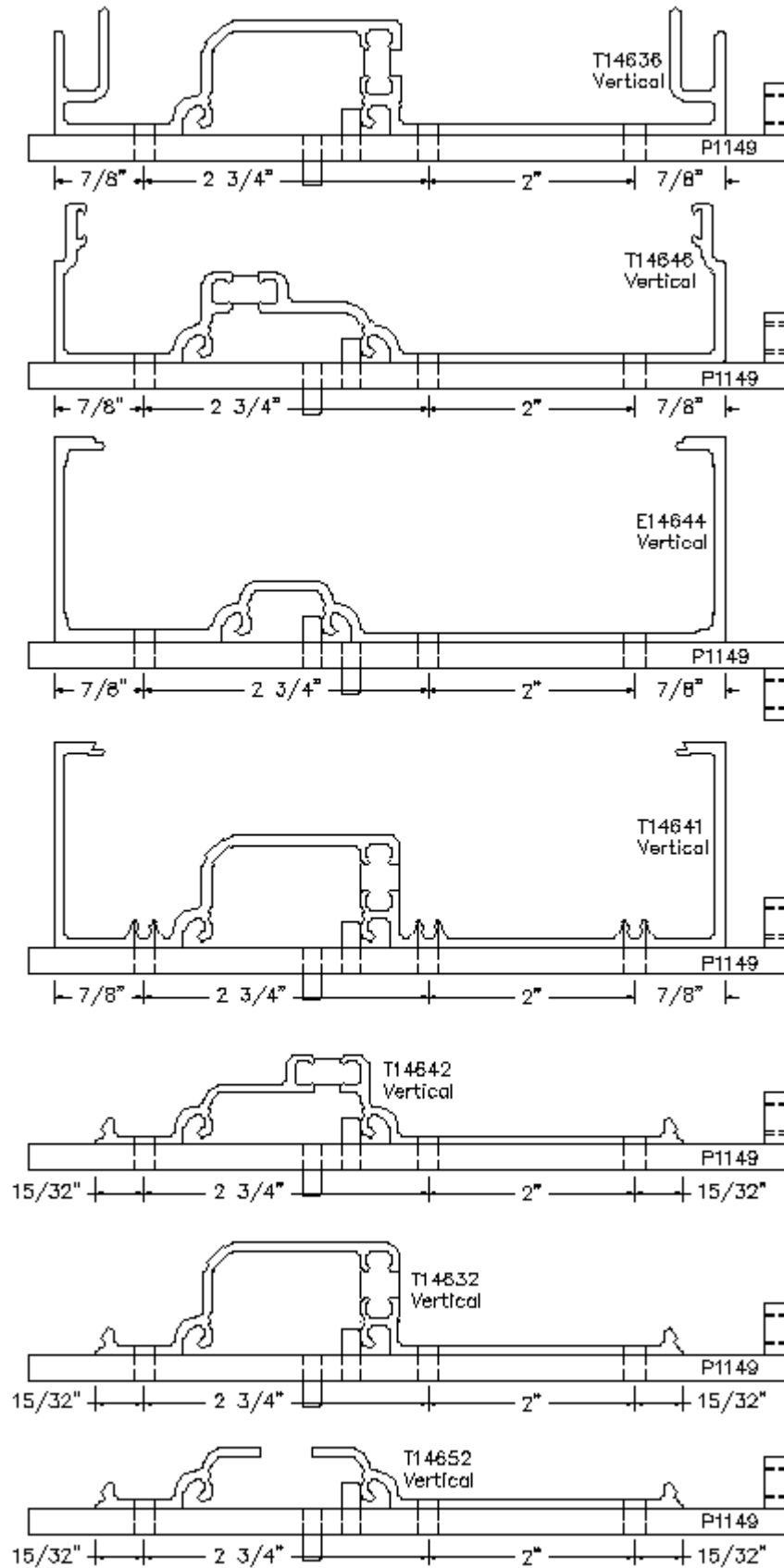

Drilling Verticals for Screw Spline Assembly

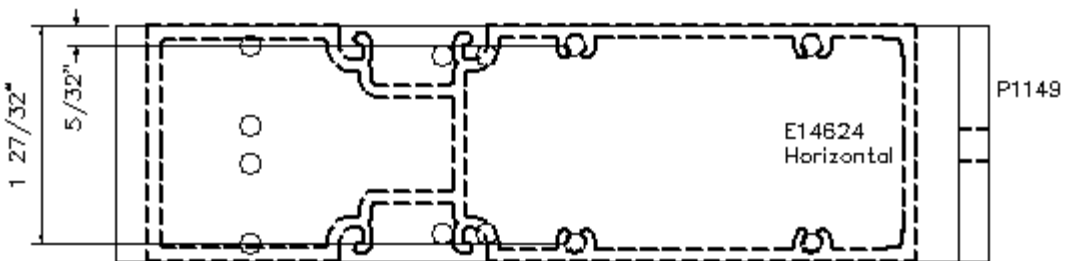
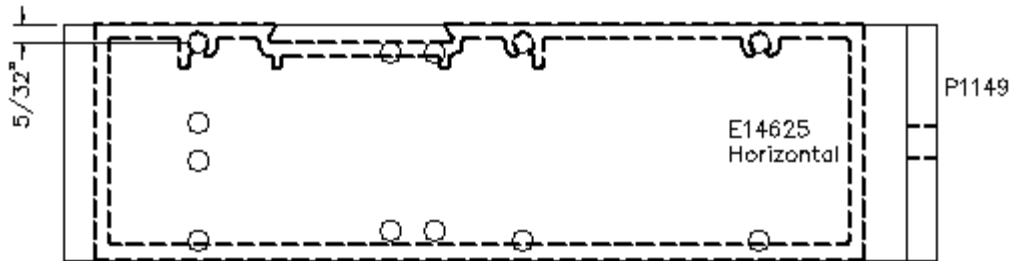
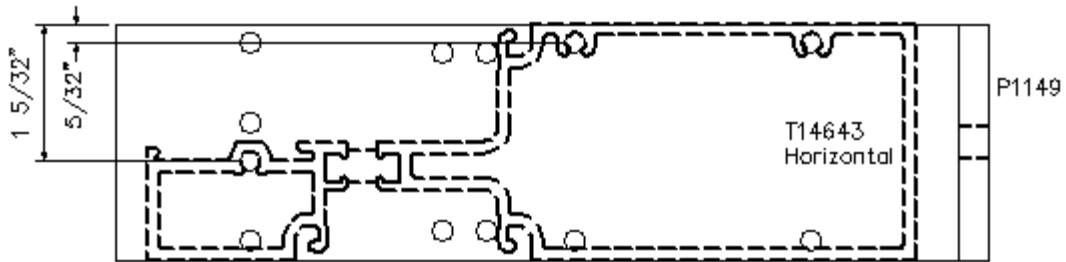
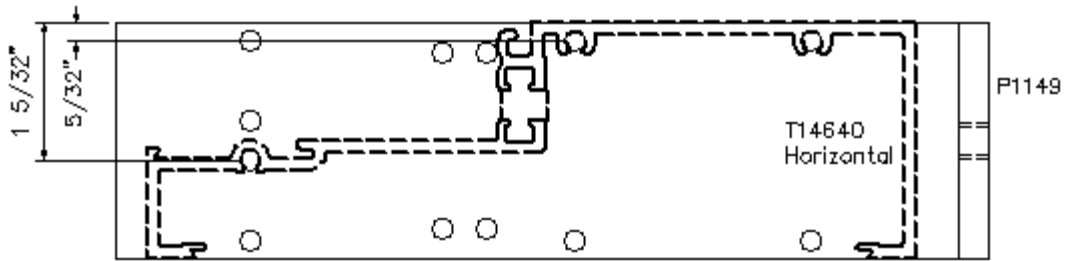
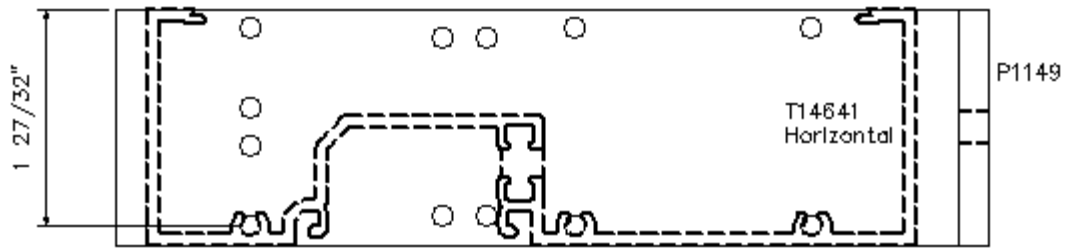

Drilling Verticals for Screw Spline Assembly

Step #5 (Shear Block Assembly): Drill holes in vertical framing members

In screw-spline assembly, screws are driven through holes in the vertical members, directly into screw splines on the horizontal members. In shear-block assembly, the installer

- Secures frame clips (also known as shear blocks) to the vertical members with screws;
- Slides the horizontal members over the frame clips; and finally
- Secures the horizontal members to the frame clips with screws.
- The screws used to secure frame clips to verticals require use of a #25 drill (.149" diameter). The following two illustrations show where to drill shear-block verticals to accommodate various types of horizontal framing members.

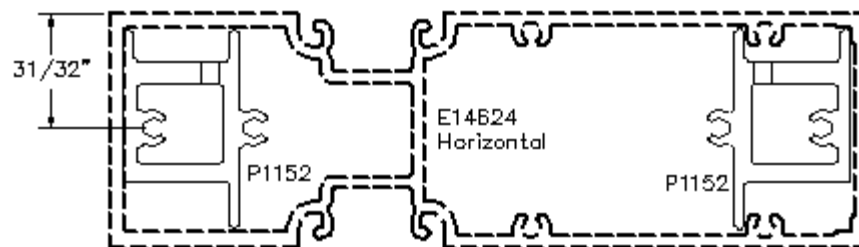
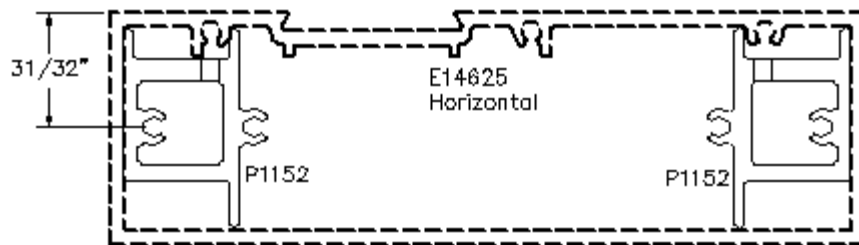
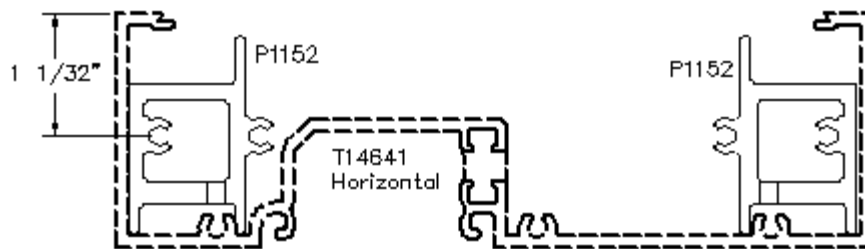
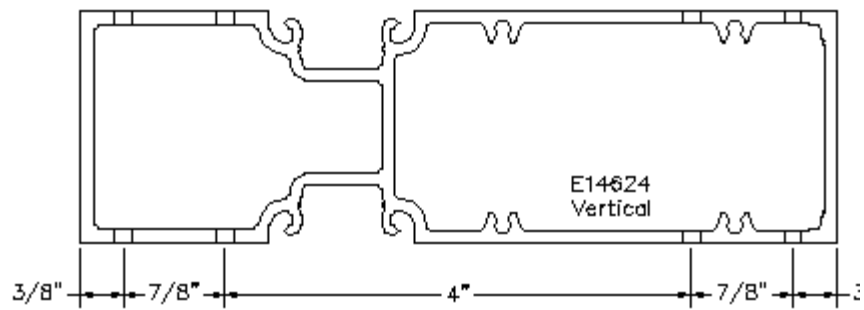
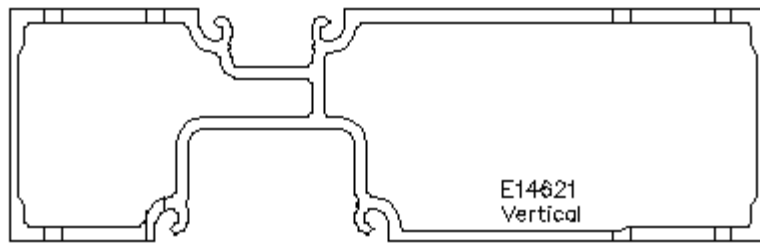

Drilling Verticals for Shear Block Assembly

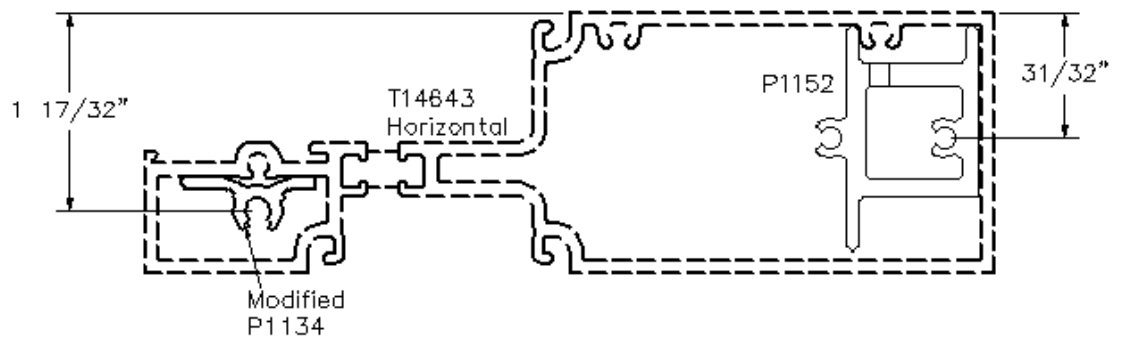
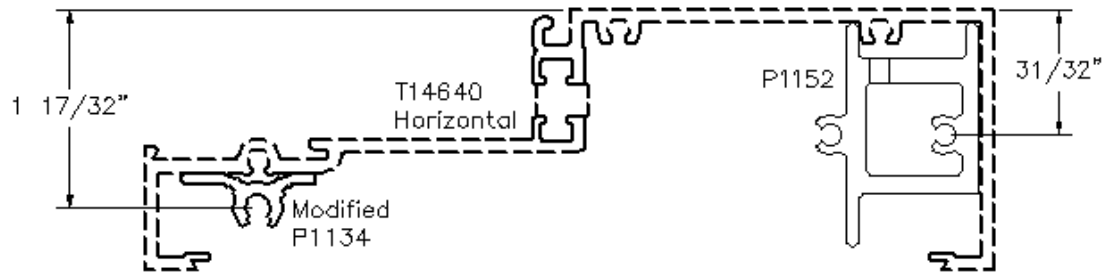
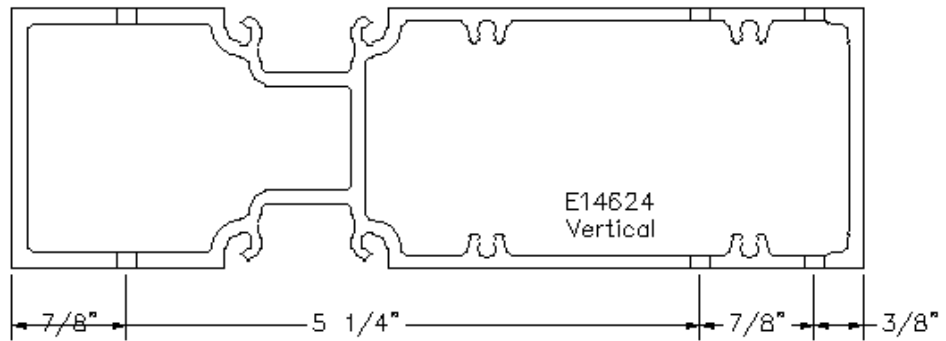
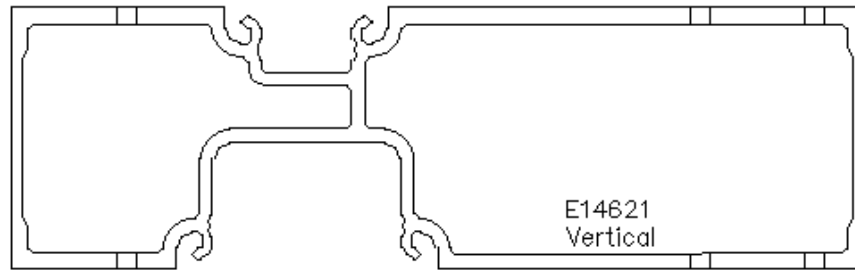

Drilling Verticals for Shear Block Assembly

Step #6 (shear-block assembly): Drill holes in horizontal framing members

Screw-spline assembly does not require drilling of horizontal framing members, because screw splines are integral to the extrusions for horizontals. The shear block assembly method, on the other hand, requires drilling of horizontals, so that they can be fastened to frame clips (shear blocks).

The illustrations in this section show the locations where holes must be drilled in the various kinds of horizontals for use in shear-block assembly. The illustrations also show the required drill sizes, because the shear-block assembly method uses screws of two different diameters to secure horizontals to frame clips.

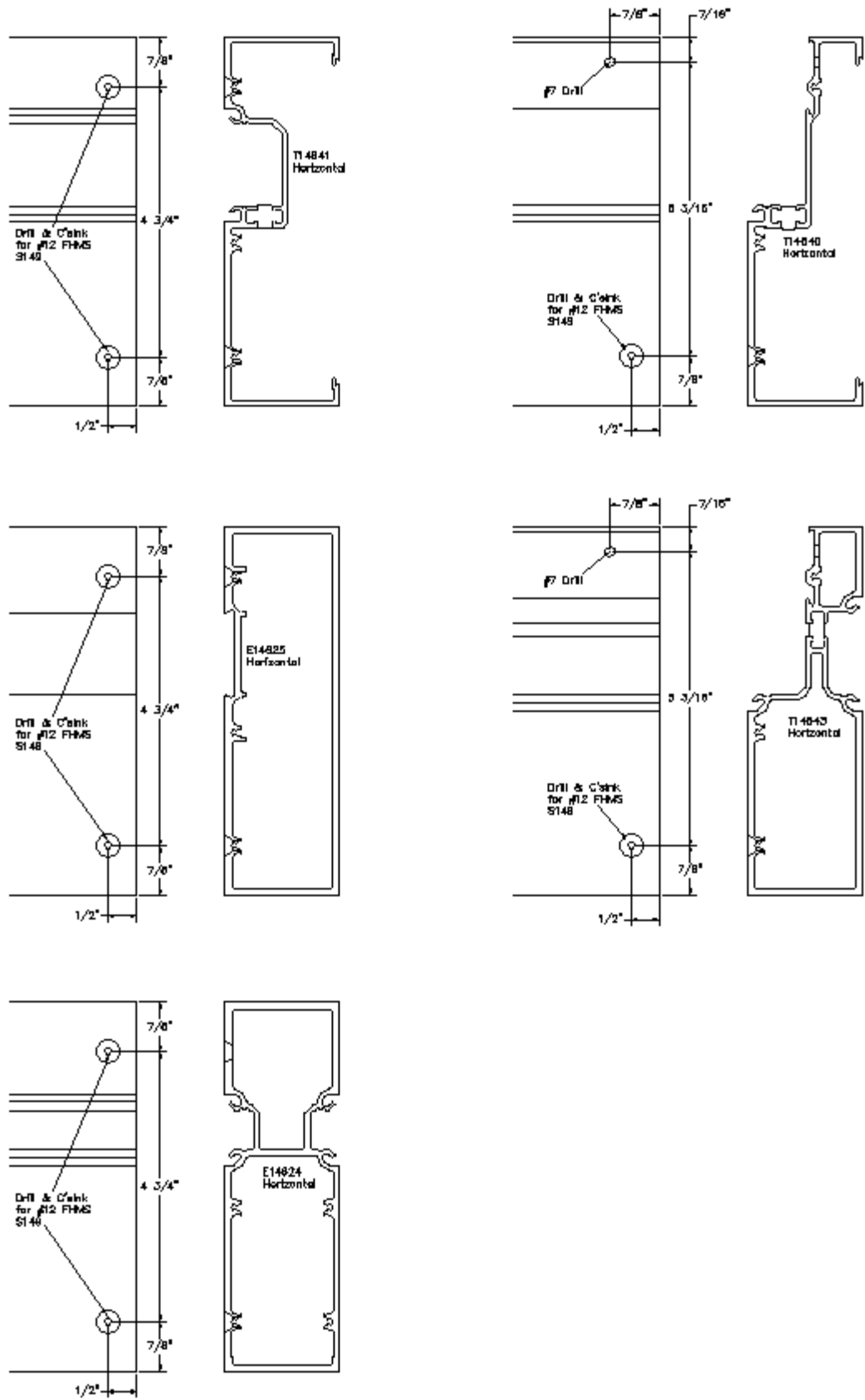

Drilling Horizontals for Shear Block Assembly

Step #7 (if needed): Cut glazing adapters to length

For installations that use 1/4" or 1/2" glass, it will be necessary to install glazing adapters (E-14036 or E14061 respectively) in the glazing pockets of the vertical and horizontal framing members that surround the lights to be glazed with 1/4" or 1/2" glass.

- For verticals, glazing adapters should be 3/32" longer than the vertical daylight opening (DLO) of the light.
- For horizontals, the length of the glazing adapters should equal the horizontal DLO, which is the same length as the horizontal framing members in which the adapters will be installed.

FRAME INSTALLATION

If there is an entrance, you should install it first, taking care to locate the entrance frame accurately within the opening.

Step #1 (if needed): *Splice the flashing where required per final distribution dwgs.*

- Place the flashing in the opening. The gap between any two pieces of flashing should be $3/8''$ to $1/2''$ wide.
- Attach the splice (P-1147) to the back of one piece of flashing with double-faced tape.
- Apply silicone sealant between the two pieces of flashing, spanning the splice.

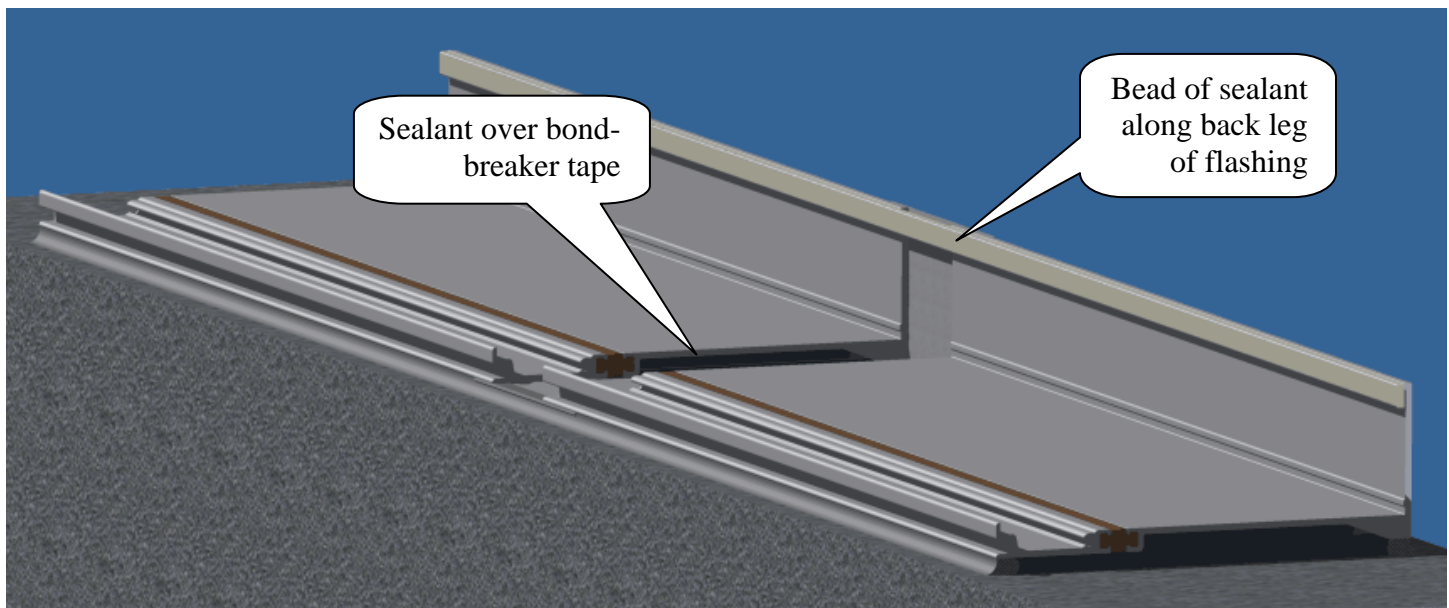

Splicing two pieces of flashing

Step #2: Seal and anchor the flashing

- At jamb conditions attach a P1154 end dam to the end of the sill flashing with two S196 screws and seal the sill flashing to the end dam as shown in the illustration on page 23.
- Butt the flashing up against the back of the door jamb (if present) and seal the flashing to the back of the entrance frame as shown in the illustration below.
- Place shims (not by Tubelite) under the flashing as needed to support the flashing and level it.
- Drill holes for anchor bolts through the flashing and into the masonry, and secure the flashing with bolts, as specified in the approved shop drawings.
- Cap seal all anchor bolts with silicone sealant.

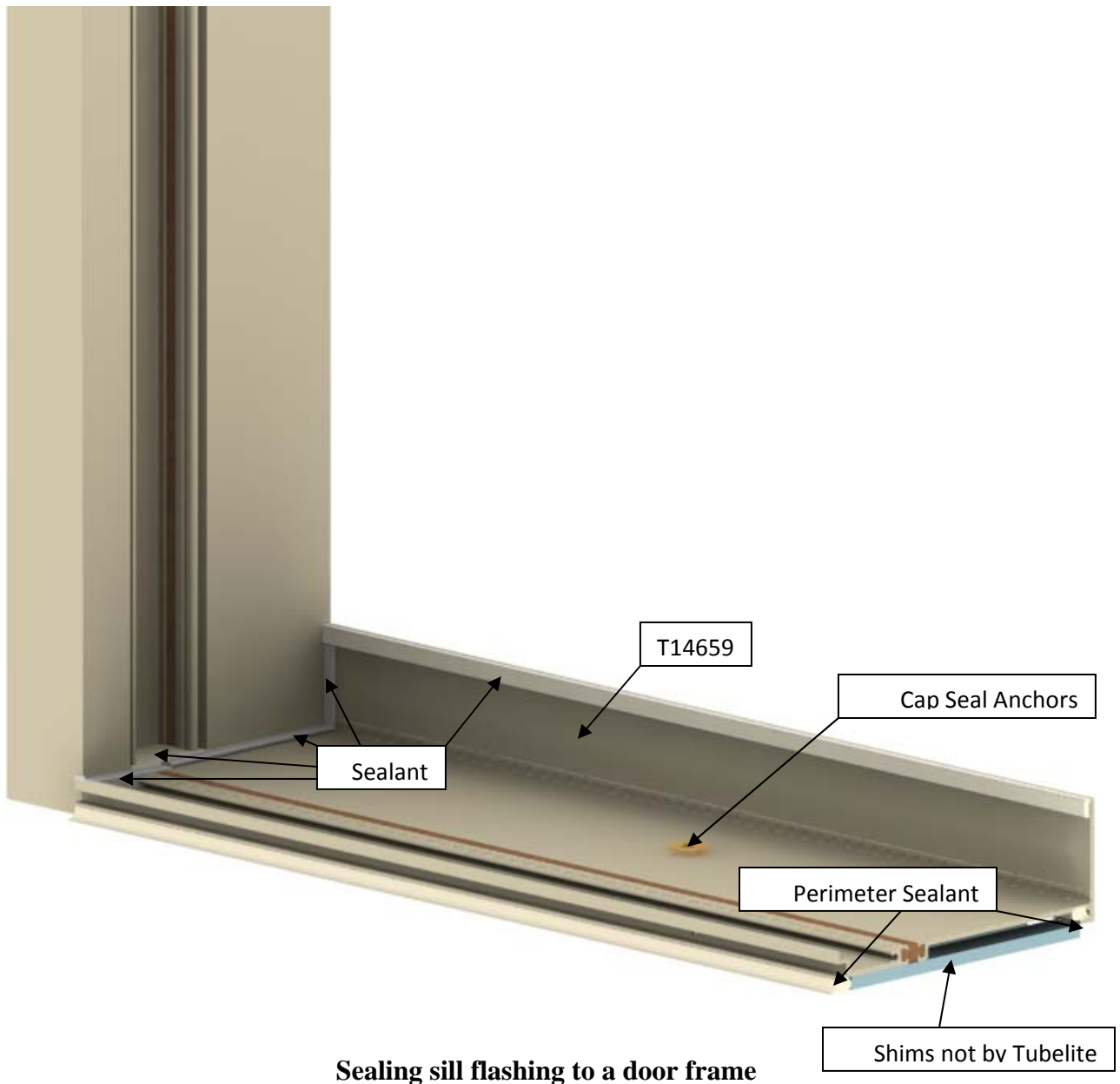

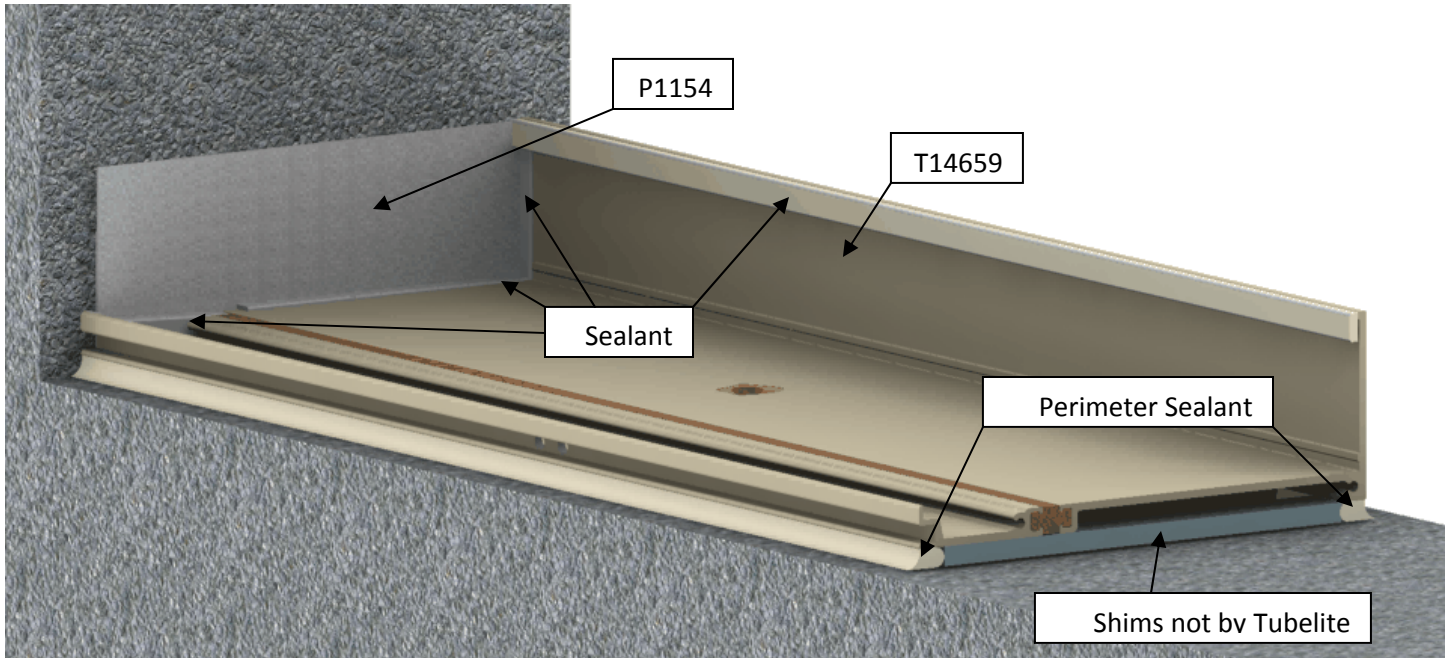

Sealing sill flashing to an end dam at a masonry wall

- Apply a bead of sealant along the back leg of the flashing from end to end, straight across any splice joint. (See splicing illustration **Error! Bookmark not defined.21 Error! Reference source not found.**)

Step #3 (shear block assembly): Seal and secure frame clips to verticals

- Modify the P1134 frame clip for the T14640 and T14643 as shown below.

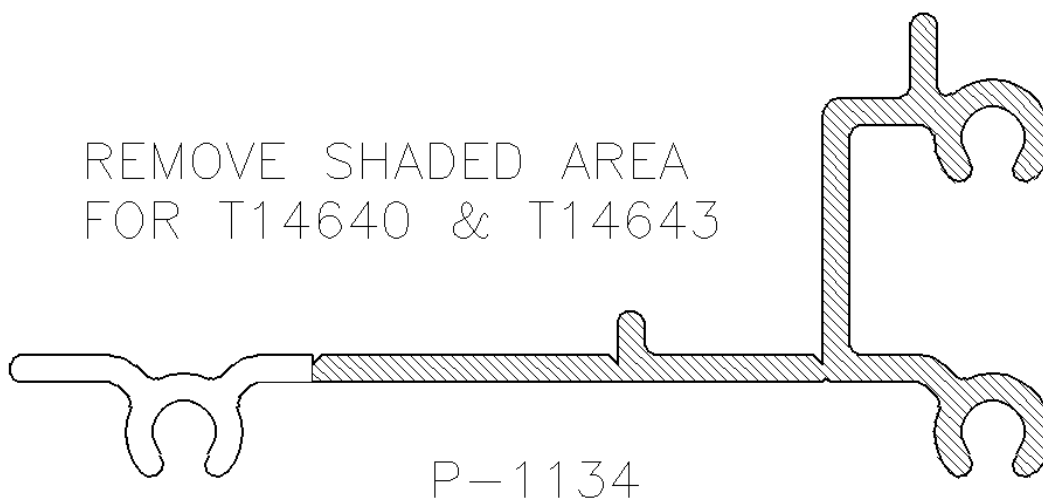

- Apply sealant to the contact edge of the shear blocks (frame clips) as shown in the illustration below, and attach to the verticals with #10 x 1 3/4" Type B Phillips pan head screws (S-009).

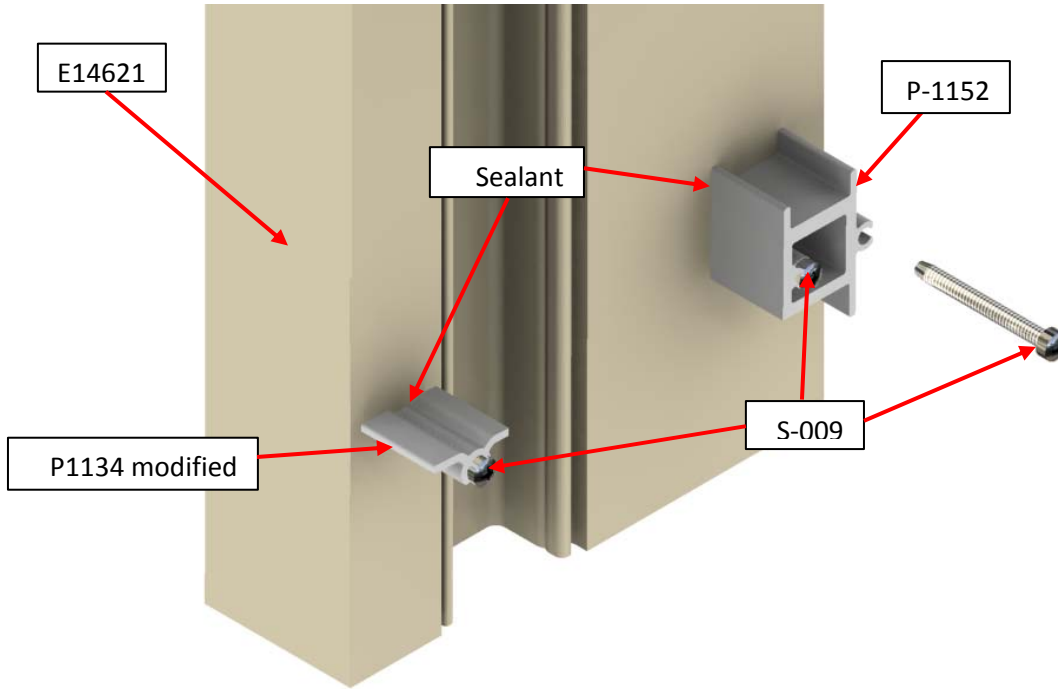

Sealing and securing frame clips to verticals

Step #4 (shear block assembly): Attach horizontals to frame clips

- Apply sealant to the contact edge of the horizontal, as shown in the illustration below.

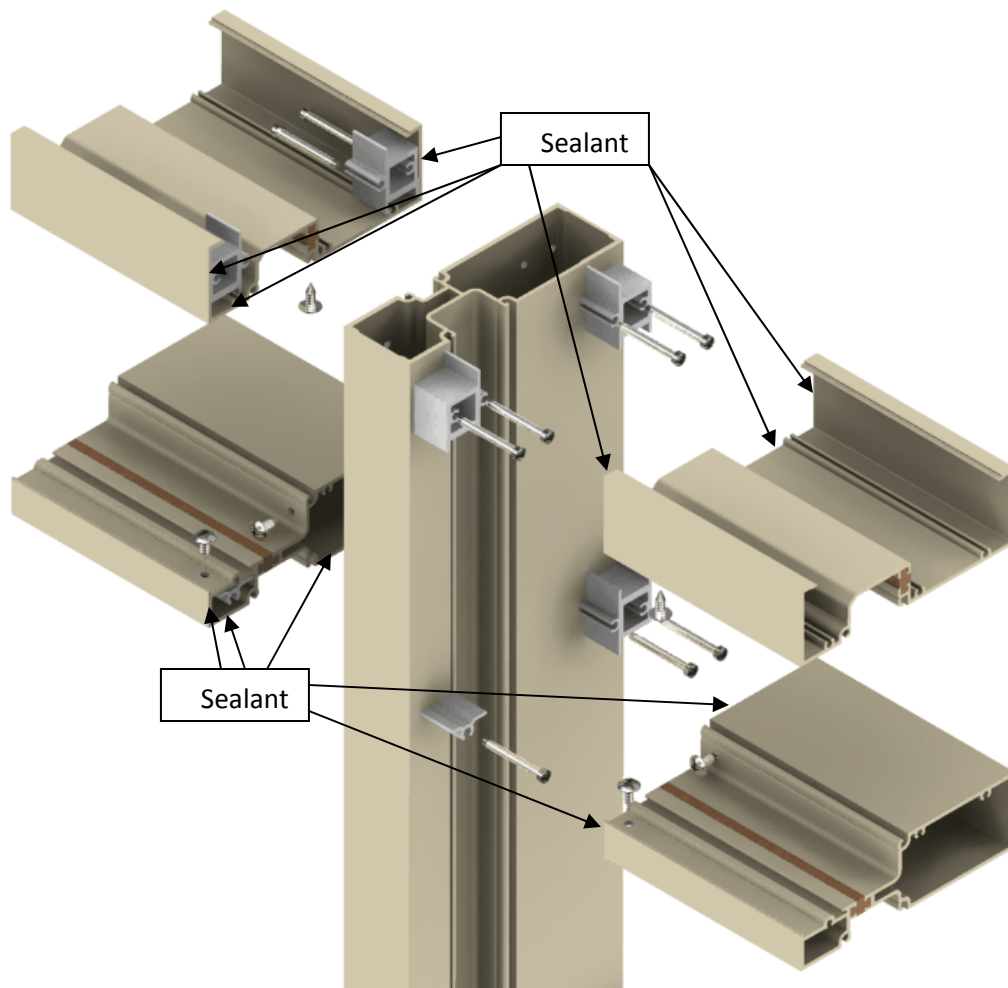

- Slide horizontals onto shear blocks (frame clips). Match drill tap holes in the shear blocks using holes in horizontals as guides, and secure horizontals to frame clips with applicable screws.
- Apply sealant to the heads of the screws which secure the horizontals to the frame clips.

Step #3 (Screw Spline Assembly): Attach horizontals to verticals

- Apply sealant to the contact edges of the horizontal as shown in the illustration below and on page 25.

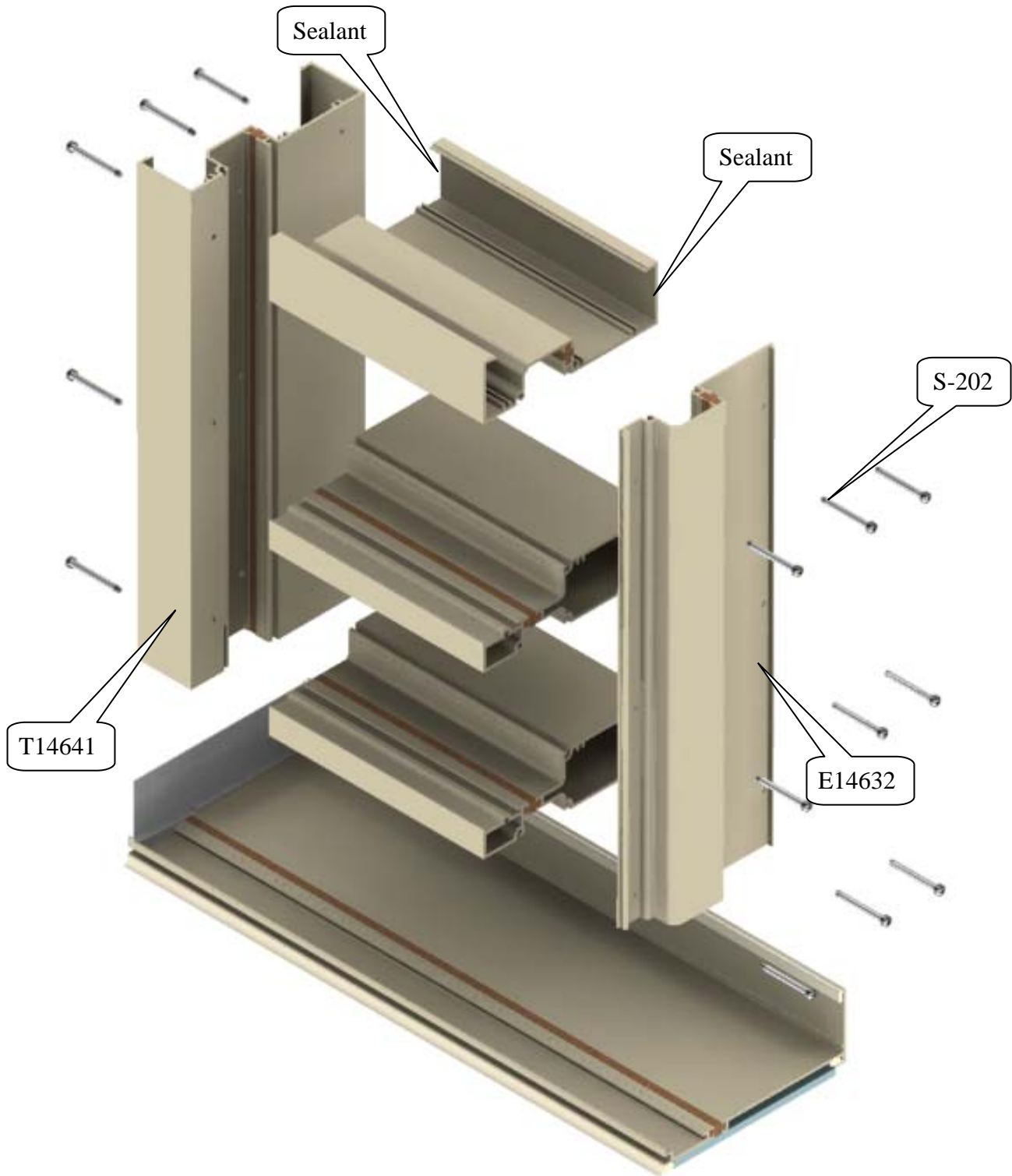

Attaching horizontals to verticals

- Secure horizontals to a vertical on one side (T14641 in the illustration above), and to a closure pocket (E14632 above) on the other side, using #10-24 x 1" Type 23 Phillips hex head screws (S-202).

Step #4: (Screw Spline Assembly): Install assembled units

- Apply sealant to end of horizontal as shown in the illustration below.

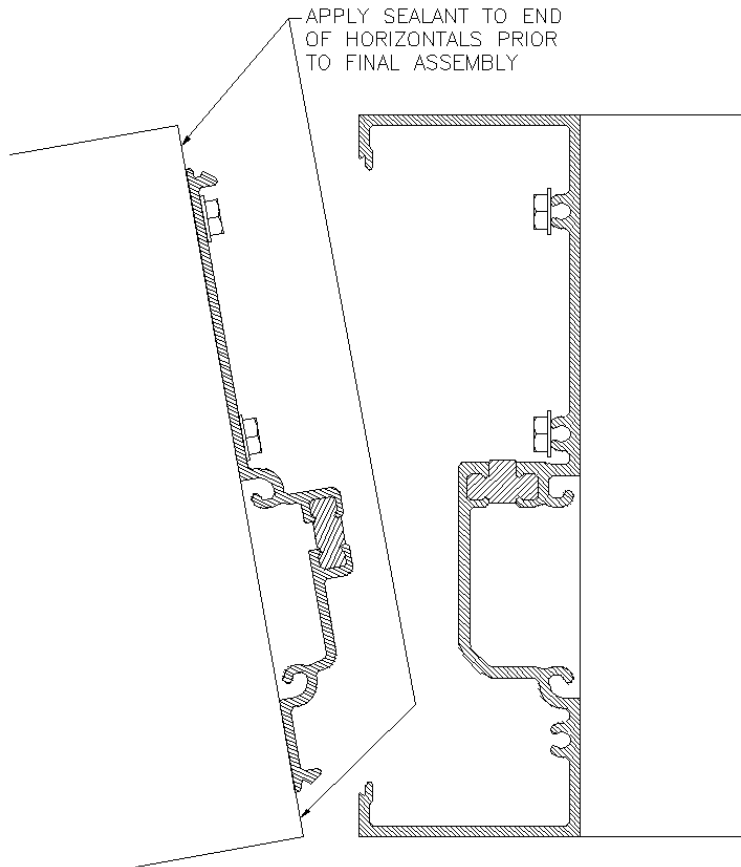

Sealing horizontal before final assembly

- Install the assembled units beginning at the entrance, and working toward the jambs. If there is no entrance, begin at one jamb and work toward the other, as in the illustration below.

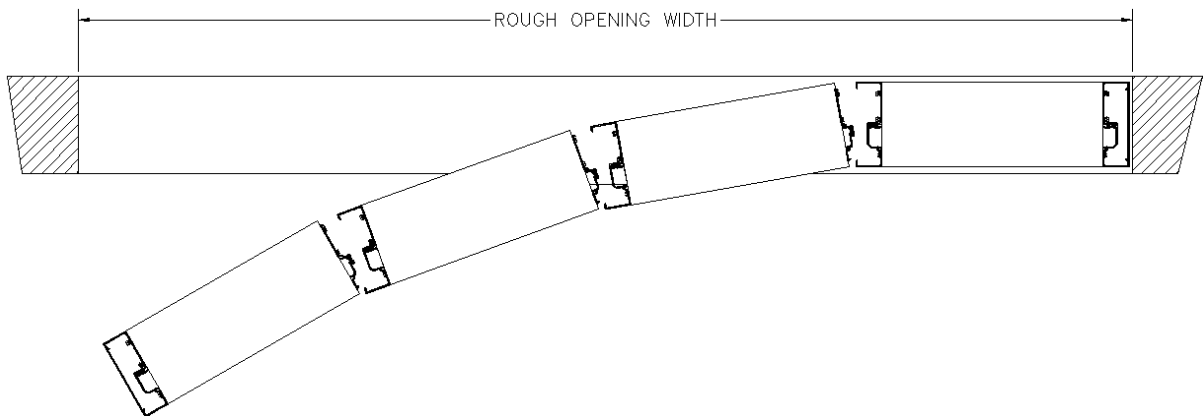

Installing assembled units

- In the case of smaller units, the last two may need to be snapped together and then pivoted into position together, as in the illustration below.

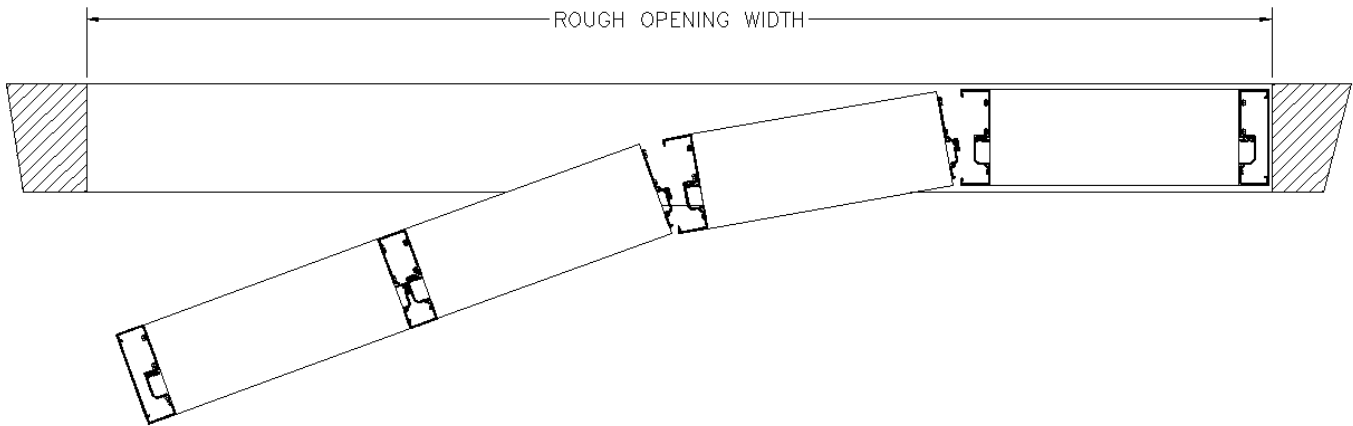

Installing last two units together

Step #5: Attach frame to masonry

- Install shims at head and jambs, as shown in the illustration below. Use a snap-in filler for open-back anchor points (P1148) to provide back-up support for shimming.

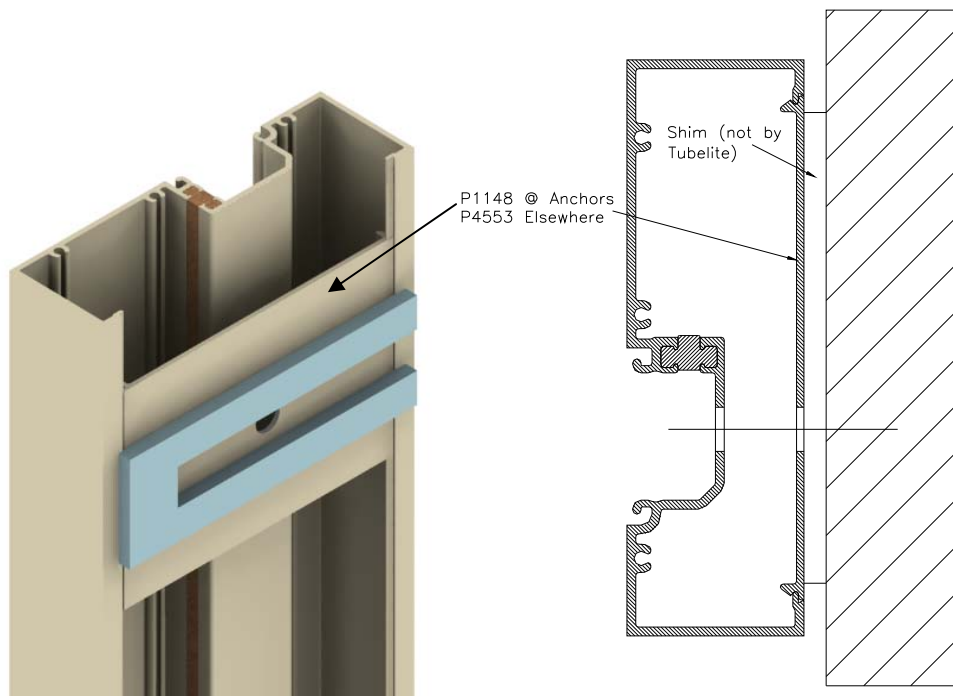

Shimming and anchoring the head and jambs

- Attach the jambs and head to the perimeter of the opening with suitable fasteners.

Step #6: Install P1135 water diverters

- Use MEK and a clean cloth to clean the surfaces of the horizontals where you will install water diverters. Also clean the vertical reglets on both sides to at least 1” above the gasket reglets on the horizontal member.

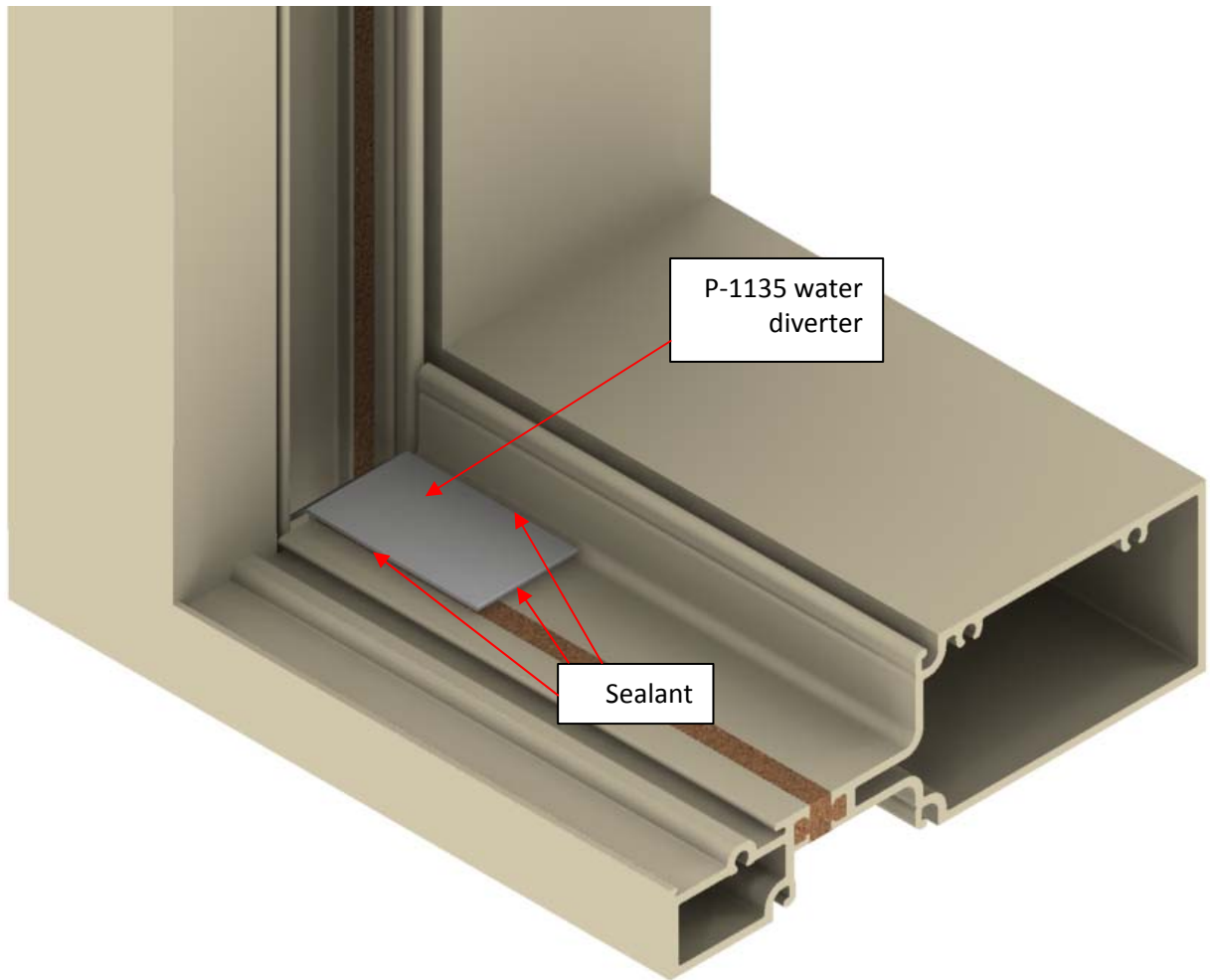

3D view of a water diverter

- When the surfaces are dry, butter the underside of the P1135 with sealant and press the diverter to the horizontal in the glazing pocket.
- Pump sealant into both vertical gasket reglets, and seal the edges of the diverter on all sides **EXCEPT** the edge facing the pocket. You must avoid getting sealant in this area in order to allow the system to drain.
- Seal the joint between the vertical and horizontal members from the diverter to the top of the horizontal gasket reglet.

GLAZING INSTALLATION

All glazing pockets are 1 7/16" wide, and will accept glazing up to and including 1 1/8" thick, dry glazed. Glass dimensions should not exceed day light opening (D.L.O.) plus 7/8". See illustration below.

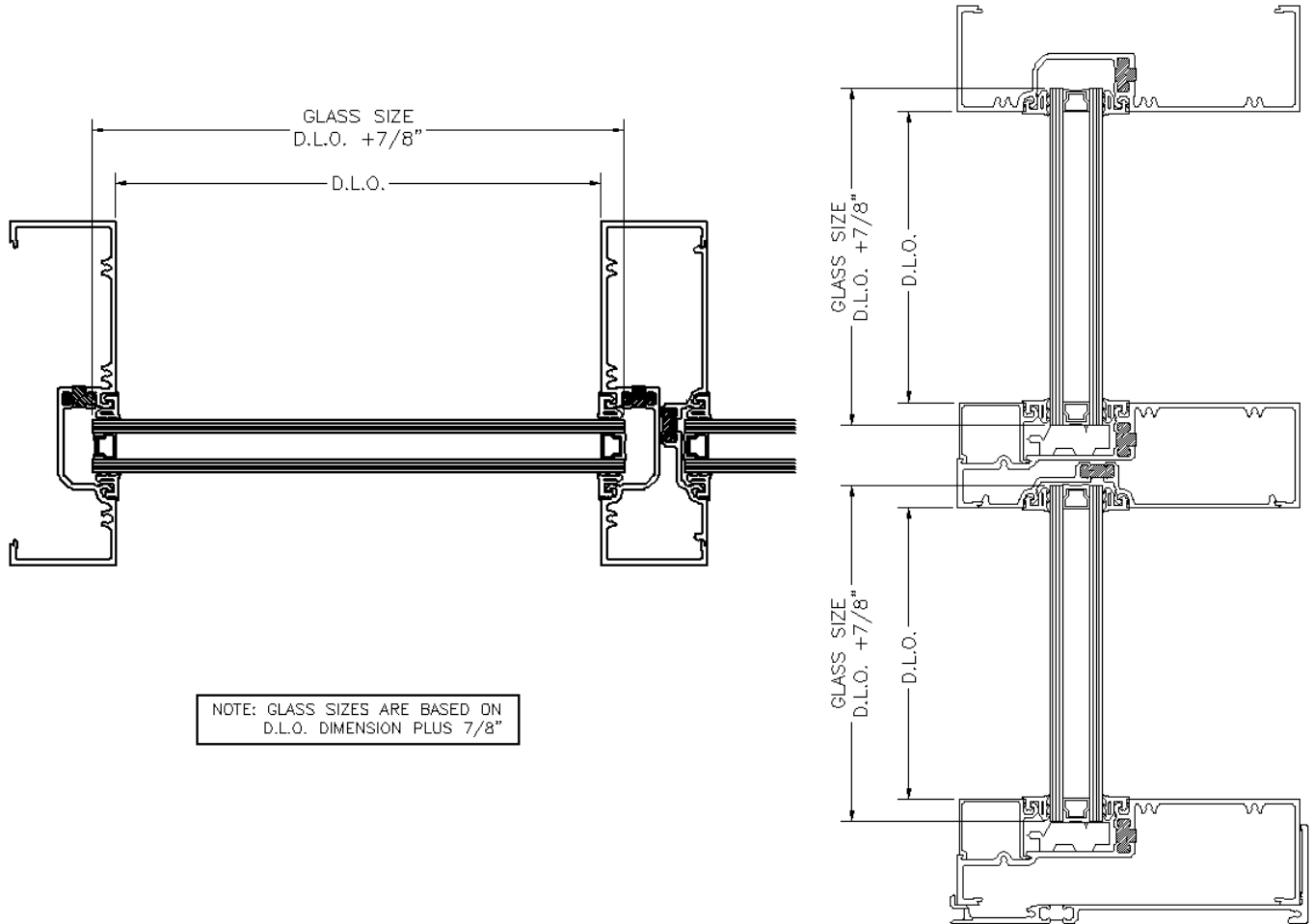

Nominal glass dimensions

This formula does not take into account out-of-square openings or glass tolerances. Consult your glass manufacturer before determining final glass sizes.

When cutting gaskets, you should add 1/16" to 1/8" per foot of daylight opening for shrinkage. (An eighth of an inch per foot is approximately 1%.) Open, unsealed gasket joints are a potential source of leakage, and water damage to interior finishes.

When installing gaskets, always begin at the ends of the gasket and work toward the center.

Step #1: Cut and install the interior gaskets

- Cut interior vertical gaskets to D.L.O. + 1" + shrinkage allowance (see above).
- Install the interior vertical gaskets, beginning 1/2" beyond the surfaces of the adjacent horizontal framing members.

- Apply butyl sealant to the interior vertical gaskets, where the horizontal gaskets will contact them.
- Cut the interior horizontal gaskets to D.L.O. + shrinkage allowance (see page 30).
- Install the interior horizontal gaskets, pressing their ends into the butyl sealant and up against the vertical gaskets.

Step #2: Install the glass

- Position the glass in the frame.
- Raise the glass off the bottom horizontal, and place a setting block (P-1132) at each quarter point (2 setting blocks per light).
- Lower the glass onto the setting blocks.

Step #3: Cut and install the exterior gaskets

- Cut the exterior vertical gaskets to D.L.O. + 1" + shrinkage allowance (see page 30).
- Install the exterior vertical gaskets. The vertical gasket should start 1/2" above the surface of the upper horizontal, and should extend 1/2" below the surface of the lower horizontal.
- Apply butyl sealant to the vertical gaskets where the ends of the horizontal gaskets will contact them.
- Cut the exterior horizontal gaskets to D.L.O. + shrinkage allowance (see page 30).
- Install the exterior horizontal gaskets, pressing their ends into the butyl sealant and up against the vertical gaskets.

Step #4: Seal perimeter of installation

- Insert backer rod into the gap between the frame and the building substrate on top, sides, and bottom of the installation.
- Apply sealant to fill the void.
- Tool the sealant smooth.

TUBELITE®

STOREFRONT, CURTAINWALL & ENTRANCES

DEPENDABLE

Tubelite Inc.

3056 Walker Ridge Drive NW, Suite G
Walker, Michigan 49544

Phone 800.866.2227

Fax 877.299.2414

www.tubeliteinc.com