

4500 Series

Fabrication and Installation Instructions

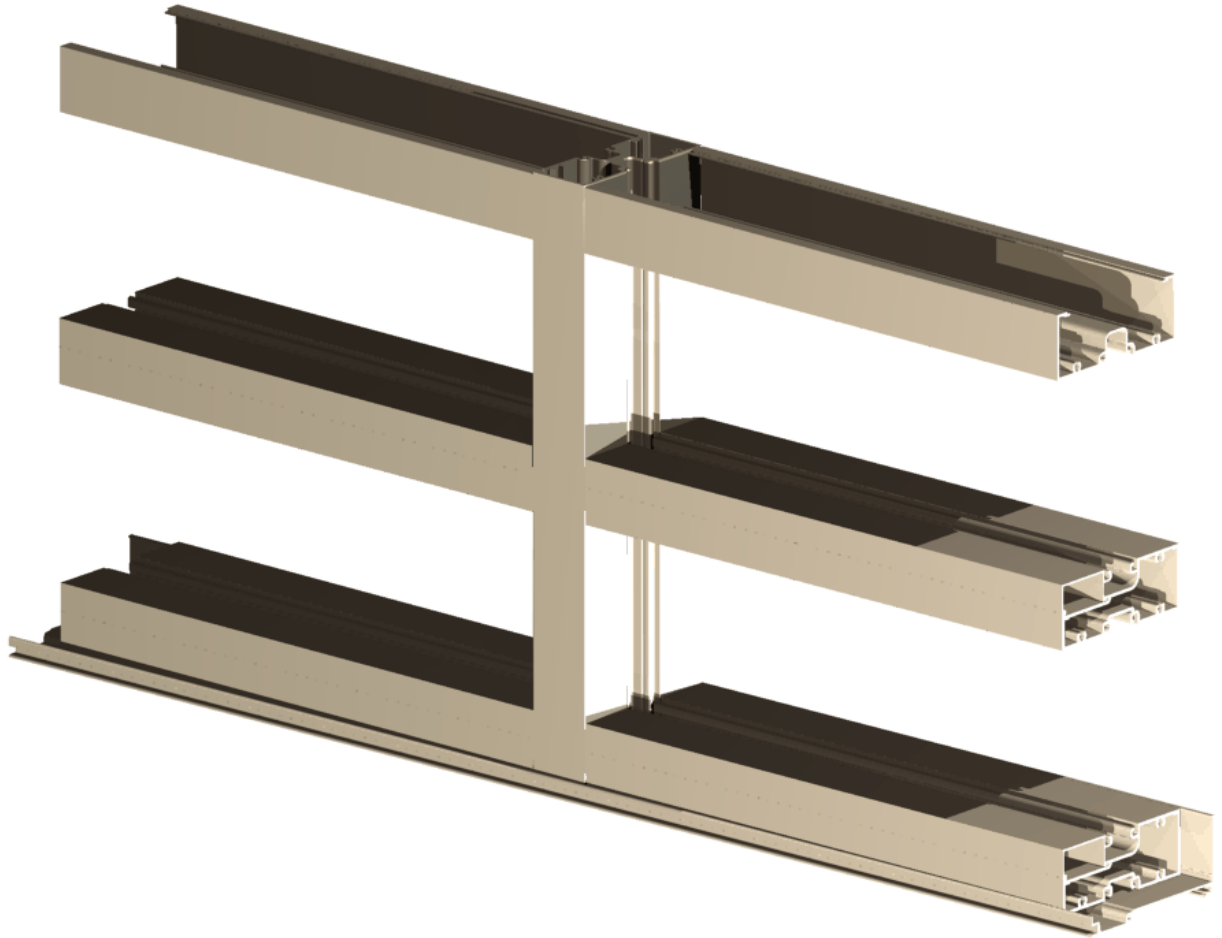

TUBELITE®
STOREFRONT, CURTAINWALL & ENTRANCES
DEPENDABLE







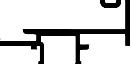



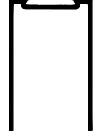
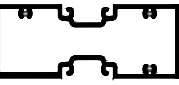

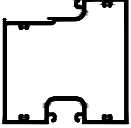

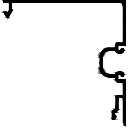

Table of Contents







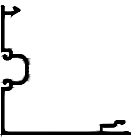
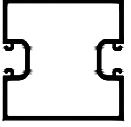
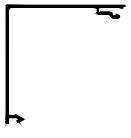
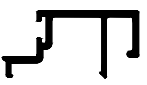
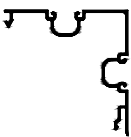

GENERAL CONSTRUCTION NOTES	3
EXTRUDED ALUMINUM PARTS	4
ACCESSORIES	6
OVERVIEW	7
FRAME FABRICATION	10
Step #1: Determine frame size.....	10
Determine frame width	10
Determine frame height	11
Step #2: Cut sill flashing to size	11
Step #3: Cut vertical framing members to size	11
Step #4: Cut horizontal framing members to size	11
Step #5 (screw spline assembly): Drill holes in vertical framing members.....	12
Step #5 (shear block assembly): Drill holes in vertical framing members	17
Step #6 (shear-block assembly): Drill holes in horizontal framing members	20
FRAME INSTALLATION	22
Step #1 : Splice the flashing where required per the final distribution dwgs.....	22
Step #2: Seal and anchor the flashing.....	23
Step #3 (shear block only): Seal and secure frame clips to verticals	25
Step #4 (shear block only): Attach horizontals to frame clips	25
Step #3 (screw spline only): Attach horizontals to verticals	26
Step #4 (screw spline only): Install assembled units	27
Step #5: Attach frame to masonry	28
Step #6: Install P878 water diverters	29
GLAZING INSTALLATION	30
Step #1: Cut and install the interior gaskets	30
Step #2: Install the glass.....	31
Step #3: Cut and install the exterior gaskets	31
Step #4: Seal perimeter of installation	31







GENERAL CONSTRUCTION NOTES

1. These instructions cover typical product application, fabrication, installation and standard conditions and are general in nature. They provide useful guidelines, but the final distribution drawings may include additional details specific to this project. Any conflict or discrepancies must be clarified prior to execution.
2. Materials stored at the job site must be kept in a safe place removed from possible damage by other trades. Stack with adequate separation so materials will not rub together, and store off the ground. Cardboard or paper wrapped materials must be kept dry. Check arriving materials for quantity and keep record of where various materials are stored.
3. All field welding must be done in accordance with AISC guidelines. All aluminum and glass should be shielded from field welding to avoid damage from weld splatter. Results will be unsightly and may be structurally unsound. Advise general contractor and other trades accordingly.
4. Coordinate protection of installed work with general contractor and/or other trades.
5. Coordinate sequence of other trades which affect framing installation with the general contractor (e.g. fire proofing, back up walls, partitions, ceiling, mechanical ducts, convectors, etc.).
6. General contractor should furnish and guarantee bench marks, offset lines and opening dimensions. These items should be checked for accuracy before proceeding with erection. Make certain that all adjacent substrate construction is in accordance with the contract documents and/or approved shop drawings. If not, notify the general contractor in writing before proceeding with installation because this could constitute acceptance of adjacent substrate construction by others.
7. Isolate all aluminum to be placed directly in contact with masonry or other incompatible materials with a heavy coat of zinc chromate or bituminous paint.
8. Sealant selection is the responsibility and option of the erector, installer and/or glazing contractor and must be approved by the sealant manufacturer with regard to application and compatibility for its intended use. All sealants must be used in strict accordance with the manufacturer's instructions and applied only by trained personnel to surfaces that have been properly prepared.
9. Sealant must be compatible with all materials with which they have contact, including other sealant surfaces. Consult sealant manufacturer for recommendations relative to shelf life, compatibility, cleaning of substrate, priming, tooling adhesion, etc.
10. Drainage gutters and weep holes must be kept clean at all times. Tubelite cannot accept responsibility for improper drainage as a result of clogged gutters and weep holes.
11. This product requires clearances at head, sill and jambs to allow for thermal expansion and contraction. Refer to final distribution drawings for joint sizes. Joints smaller than ¼" may be subject to failure. Consult your sealant supplier.
12. All materials are to be installed plumb, level and true with regard to established bench marks and column center lines established by the general contractor and checked by the erector, installer and/or glazing contractor.
13. Cleaning of exposed aluminum surfaces should be done per AAMA recommendations.

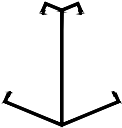

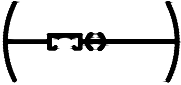
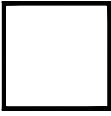



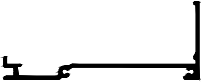



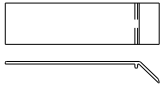











EXTRUDED ALUMINUM PARTS

Shape	Description	Part No.	Shape	Description	Part No.
	Open Back Head, Jamb/Vertical	E4541		Snap-in Glazing Gutter	E4026
	Pocket Closure for Open Back Members	E4542		Screw applied Gutter	E4014
	Open Back Sill/Horizontal/Head	E4540		Glazing Stop	E4015
	Sill Flashing	E45159		Snap-in Glazing Gutter	E4013
	Glazing Stop	E4504		Intermediate Horizontal	E4503
	Open Back Door Jamb	E4544		4" Sidelight Base	E14026
	Door Header/Transom Bar	E45123		Sidelight Base Anchor Channel	E14027
	Door Header/transom Bar	E45124		4 1/2" x 4 1/2" Sidelight Base/Horizontal	E4534
	Heavy wall vertical mullion	E4552		One Pocket Corner	E45108
	Vertical mullion	E4500		One Pocket Corner	E45109
	4 1/2" x 4 1/2" Vertical mullion	E45009		Pocketless corner	E45110
	Door stop	E4531		Two pocket corner	E45111

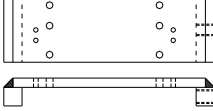
Shape	Description	Part No.
	Screw applied door stop	E2298
	Open Back Door Jamb	E4545
	1 3/4" x 4 1/2" Tube	E0041
	4" x 4 1/2" Tube	E14080
	Head Receptor Female Half	E14129
	Head Receptor Male Half	E14130
	Head Receptor Channel	E45116
	Snap-in Pocket Filler	E4011
	Flat Closure for Open Back Members	E4543

Shape	Description	Part No.
	135° Corner	E45005
	Rotational mullion	E45248
	Center pivot member for E45248	E14247
	4 1/2" x 4 1/2" Tube	E0133
	Expansion Vertical - Male Half	E4506
	Expansion Vertical - Female Half	E4507
	1 3/4" x 4 1/2" Open-back tube	E0405
	Snap-in back with nail fin	E4553
	Extruded sill flashing	E14159

ACCESSORIES

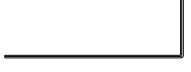
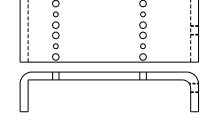
Shape	Description	Part No.	Shape	Description	Part No.
	Roll-In Glazing Gasket	P2428		Water Diverter	P878
	Roll-In Glazing Gasket	P487		#10 x 1" Type 23 - Screw Spline Phillips/Hex Head Fastener	S202
	Improved Bulb type Gasket – use with E14129/E14130	P2511		#10 x 1 3/4" Type B Phillips Pan Head Screw Fastener for clip to horizontal attachment.	S009
	Wiper Gasket (use with E45116 & E45248)	P1221		#10 x 5/8" Phillips Flat Head for Clip Joint Connections	S192
	Pile Weathering with vinyl fin	P1098A		#12 x 3/4" Type B Phillips Flat Head Screw	S149
	Setting Block	P575		#10 x 1/2" Type B, Phillips Truss Head	S191
	Frame Clip	P531		Steel Reinforcing-Primer Painted 12'-0" lengths	P1437
	Frame Clip	P532		Splice Sleeve for E45159 Sill Flashing, with tape	P1143
	Frame Clip	P917		Drill Fixture	P796 B
	Door Stop Header Filler Block	P503		5/16" - 18 threaded swivel pad thumb screw w/ delrin tip for P1139	P1682
	Clip for Sidelight Base E14026	P1137		PVC Closure – plate snap fits with open back frames, 10'0" lengths	P4543A
	End Dam for sill flashing	P1142		Subsill end dam	P1153
	Subsill splice	P1144		Drill Fixture	P1139

OVERVIEW

There are two distinct methods for assembling the 4500 Series: screw spline assembly, and shear block (frame clip) assembly.

The illustration below shows the elevation view of a typical 4500 Series installation. The number in the top half of each circle is the number of a figure showing details of the associated system component; the number in the bottom half of each circle gives the page number on which that figure appears.

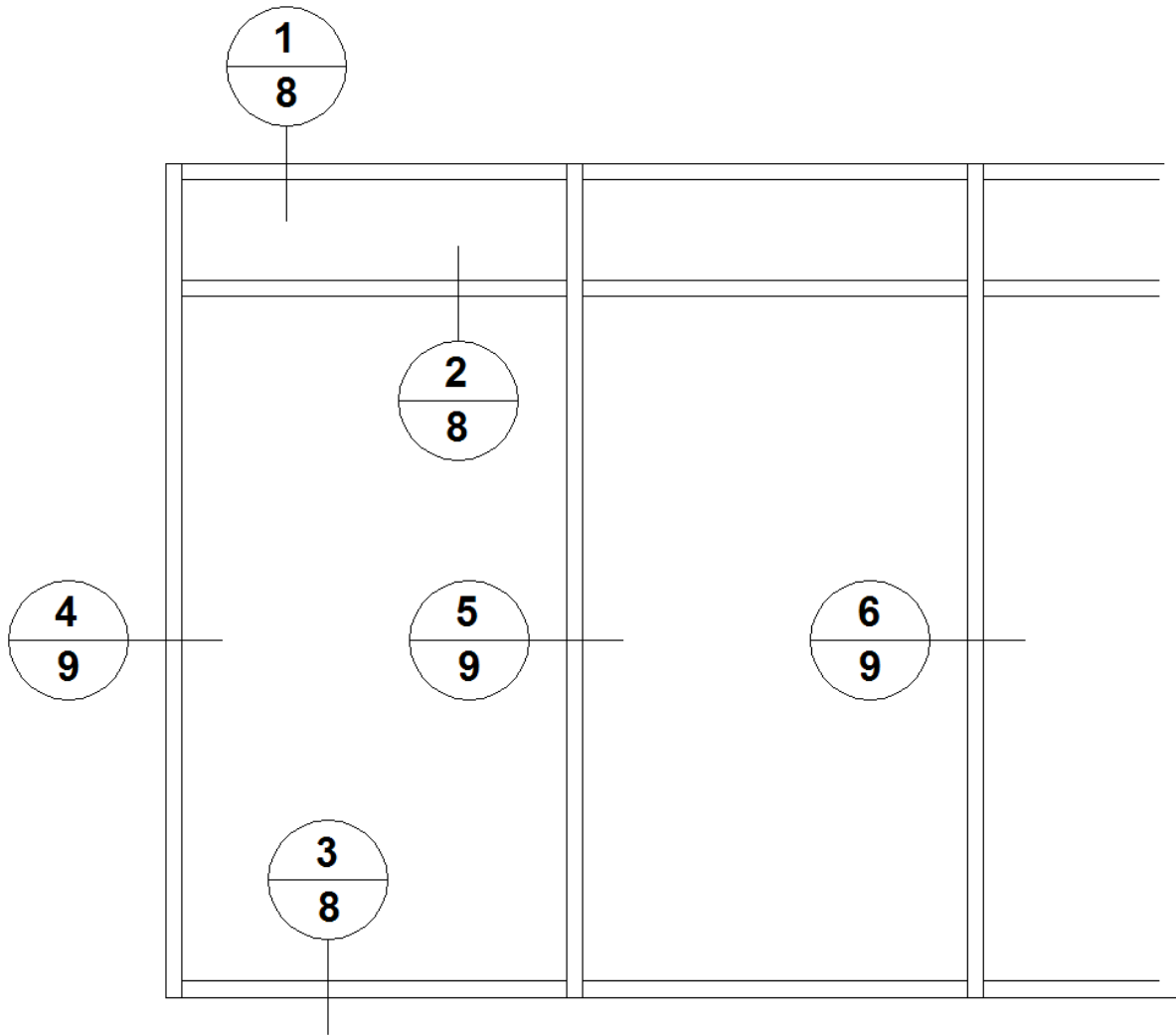

Elevation of a typical 4500 Series installation

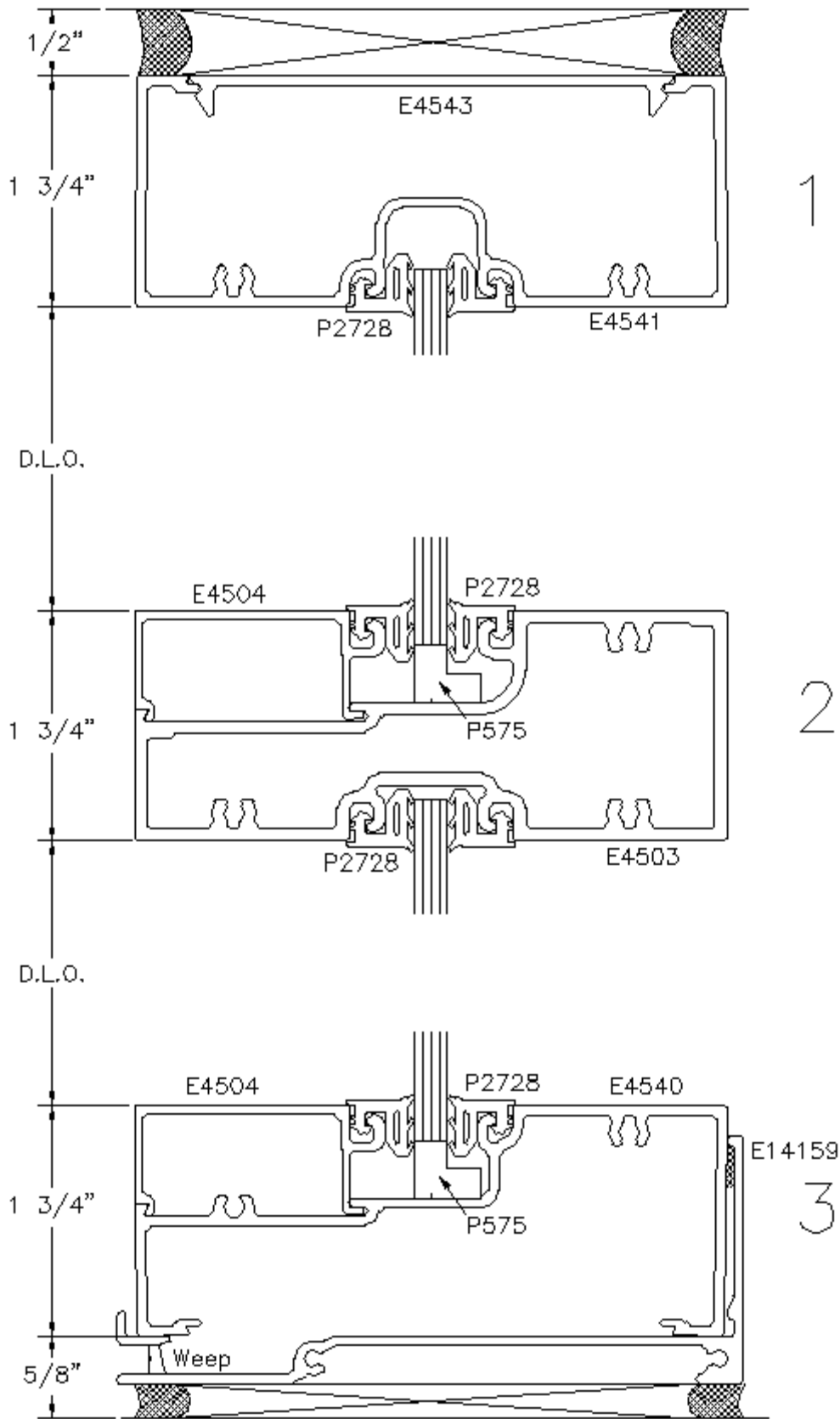

Typical horizontal details

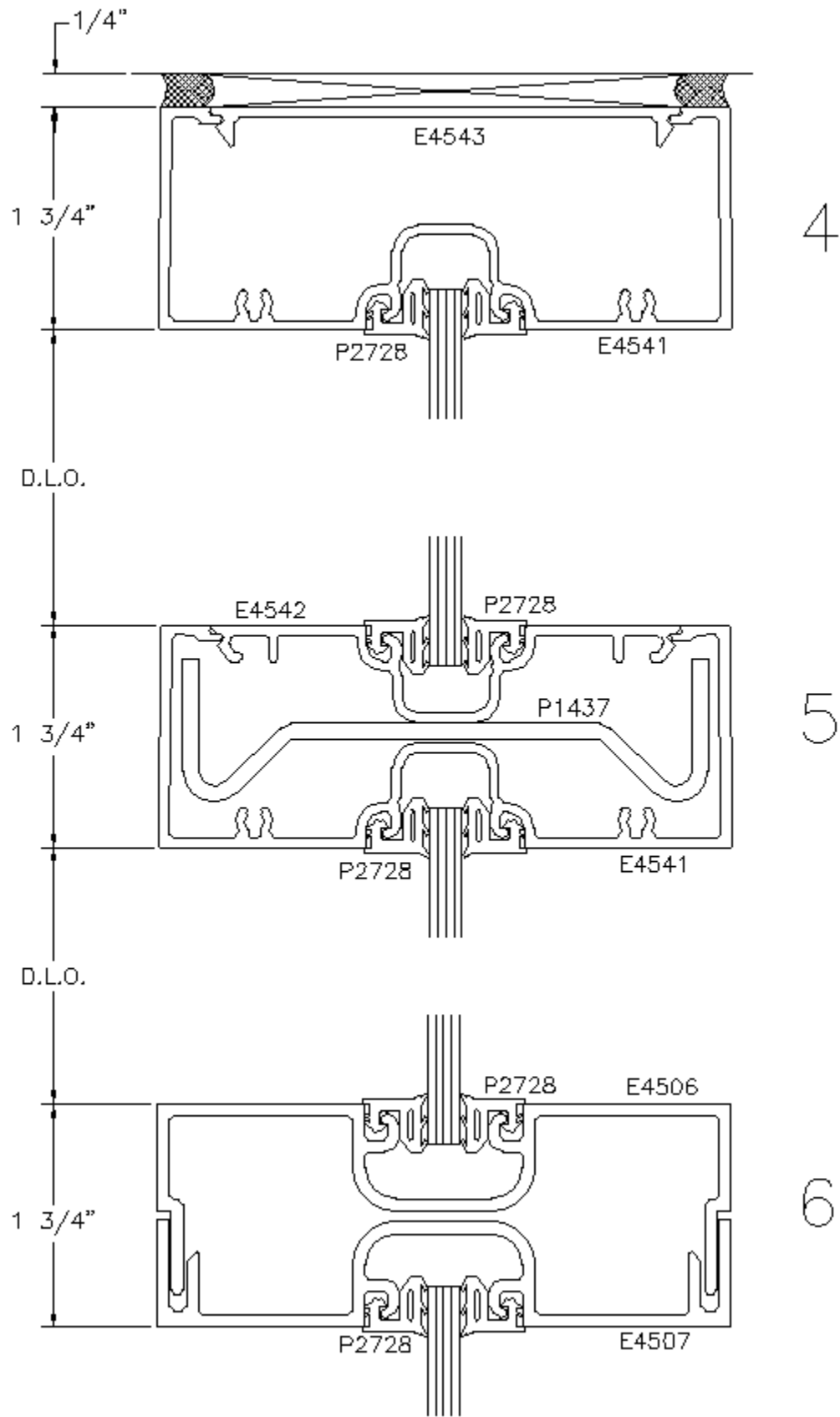

Typical vertical details

FRAME FABRICATION

Step #1: Determine frame size

Determine frame width

Check that the opening is square and plumb at both ends. Units must be installed in a true rectangle.

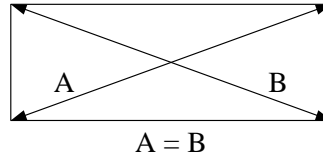

- Measure the width of the masonry opening at the top, middle and bottom.
- Select the smallest dimension measured. To determine the frame width to be used, subtract a minimum of 1/2" from the smallest measured width, to allow a minimum of 1/4" at each jamb for shimming and caulking. Allow a larger clearance if necessary to accommodate building tolerances, an out-of-square opening, and/or anticipated thermal expansion within the unit.

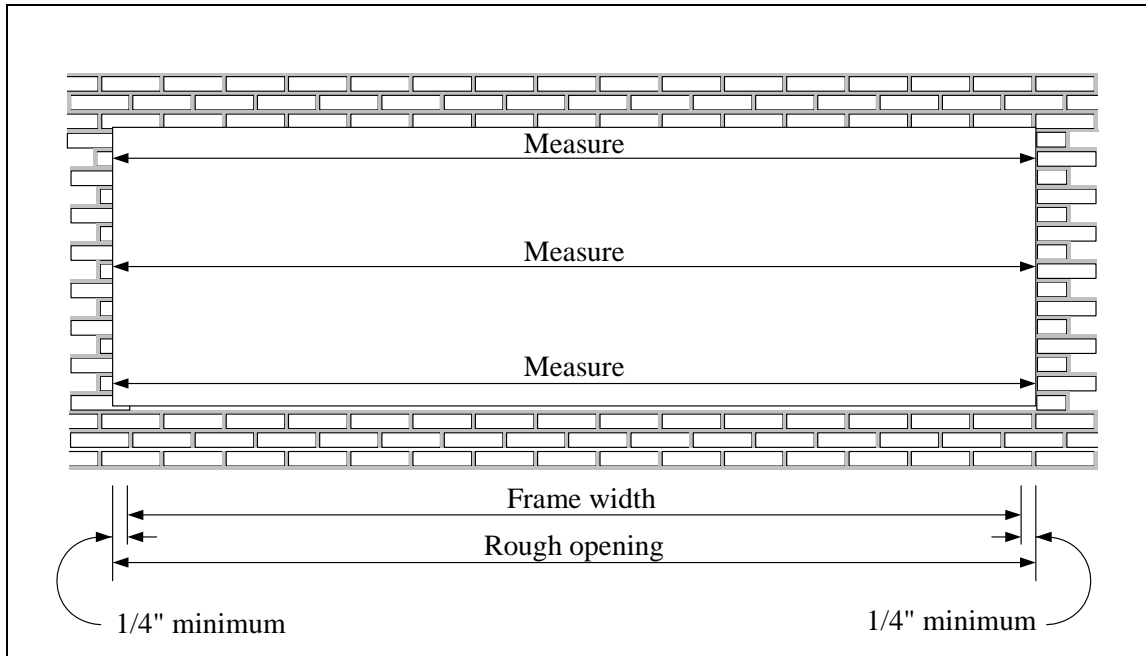

Determine frame height

- Measure the height of the masonry opening in several places along the entire length of the opening.
- To determine the frame height to be used, select the smallest dimension measured and subtract 1 1/8" to allow a minimum of 5/8" at sill and 1/2" at head for shimming and caulking. Allow a larger clearance if necessary to accommodate building tolerances, an out-of-square opening, and/or anticipated thermal expansion within the unit.

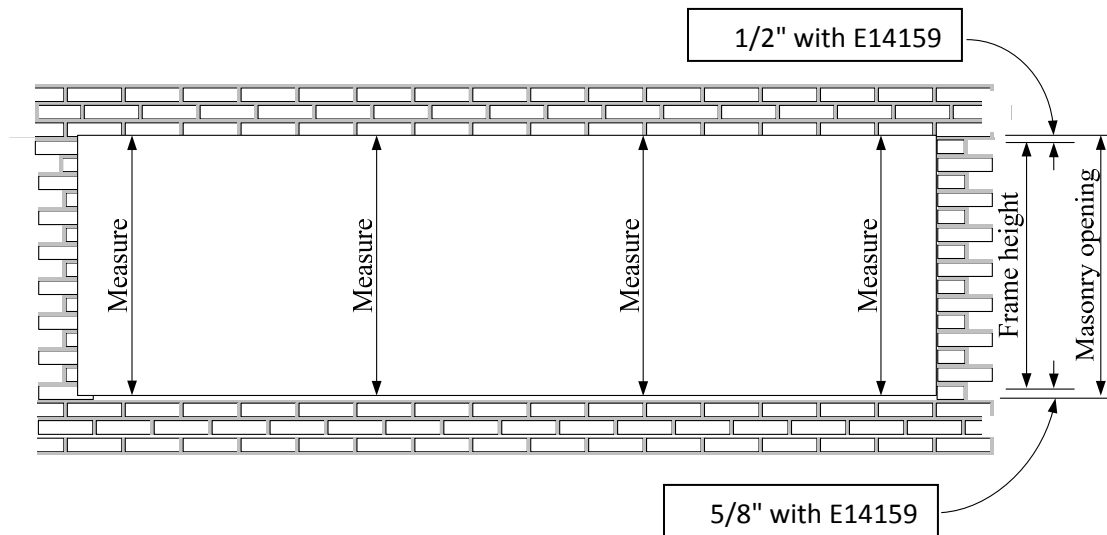

Step #2: Cut sill flashing to size

- Cut flashing (E-14159) to frame width determined in Step #1 on page 10 (rough opening minus clearances). If the installation is to include an entrance, the flashing should butt against the back of the door jamb (no clearance).
- Flashing longer than 24' in length must be spliced using part number P-1144. If flashing must be spliced, allow 3/8" to 1/2" for the width of the splice.
- At the quarter points of each light, drill 7/32" diameter holes in the sill flashing. Install a PTB42 weep baffle in the gutter of the extruded sill flashing behind each weep hole.

Step #3: Cut vertical framing members to size

- Verticals should be the frame height found in Step #1 above (rough opening height minus clearances).
- As shown in the elevation overview on page 7, vertical framing members run through.

Step #4: Cut horizontal framing members to size

- Cut horizontal framing members to the daylight opening (the distance between verticals).
- For easier installation, cut horizontal glazing beads 1/32" shorter than the horizontal framing member.

Step #5 (screw spline assembly): Drill holes in vertical framing members

In screw-spline assembly, screws are driven through holes in the vertical members, directly into screw splines on the horizontal members. These screws are what support the horizontal members and the glass. The four drawings in this section show where to drill the holes in the vertical members so that they line up with the screw splines on the horizontals.

- The screw used for screw-spline assembly is a #10-24 x 1" Type 23 Phillips hex head (S-202). To accommodate this type of screw, the holes in the vertical framing members must be .201" in diameter, corresponding to a #7 drill.
- Tubelite offers a drill fixture (P796B) to help locate the correct hole locations quickly and accurately. This fixture is designed for use on both screw-spline and shear-block projects.

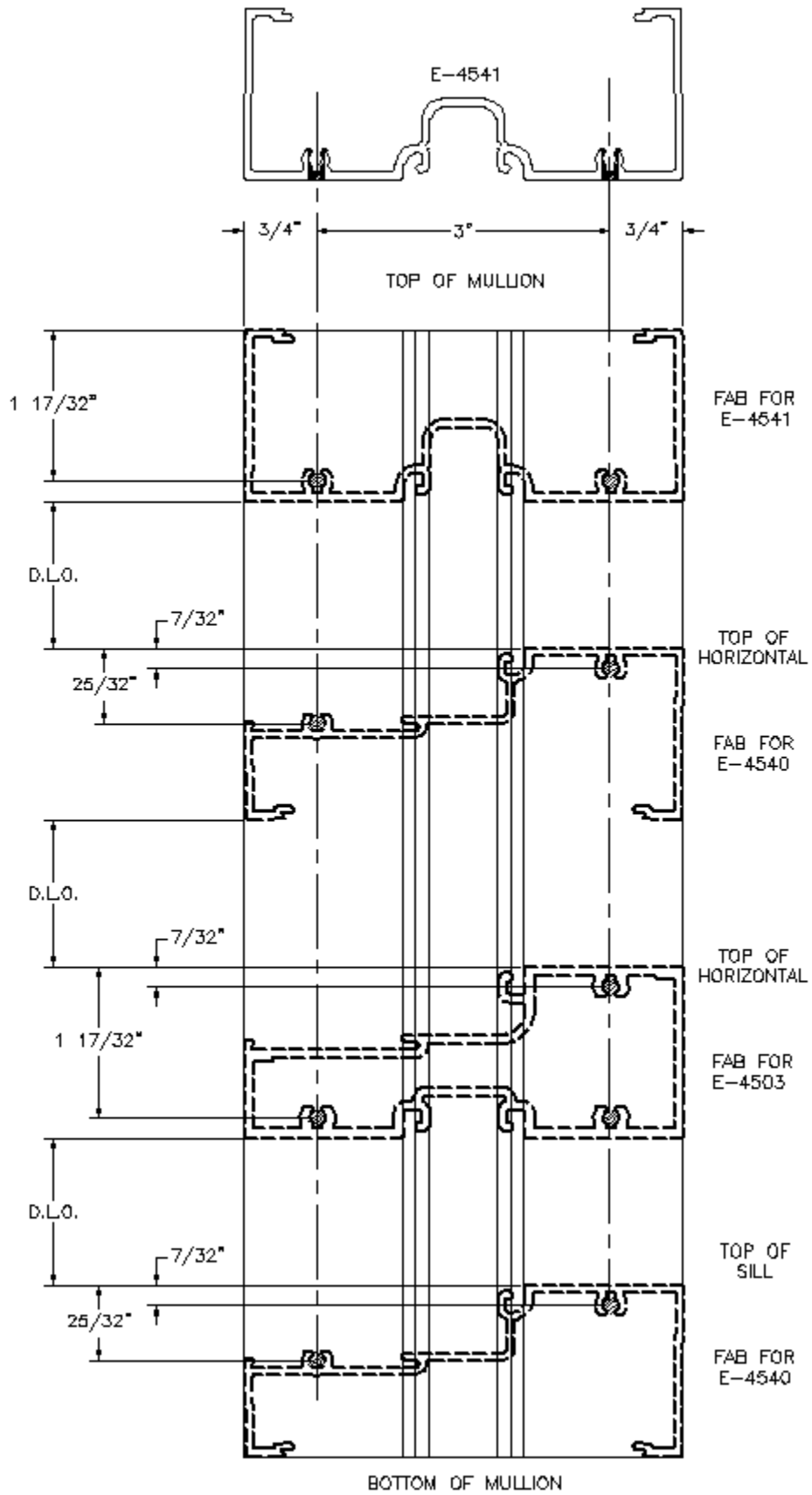

**Drilling an open-back vertical (E-4541) --
Screw-spline, no door or sidelight**

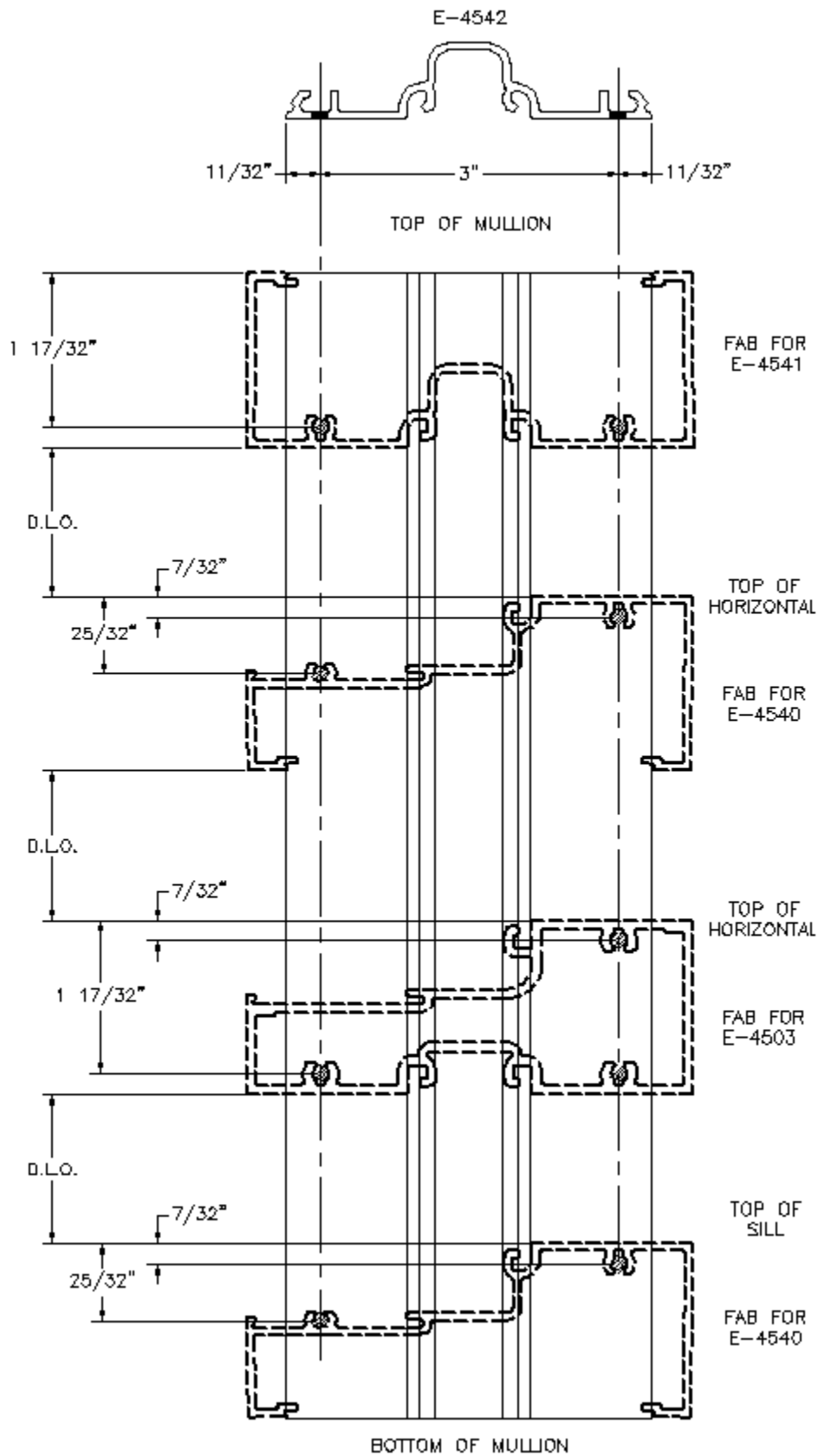

**Drilling a closure pocket (E-4542) --
Screw-spline, no door or sidelight**

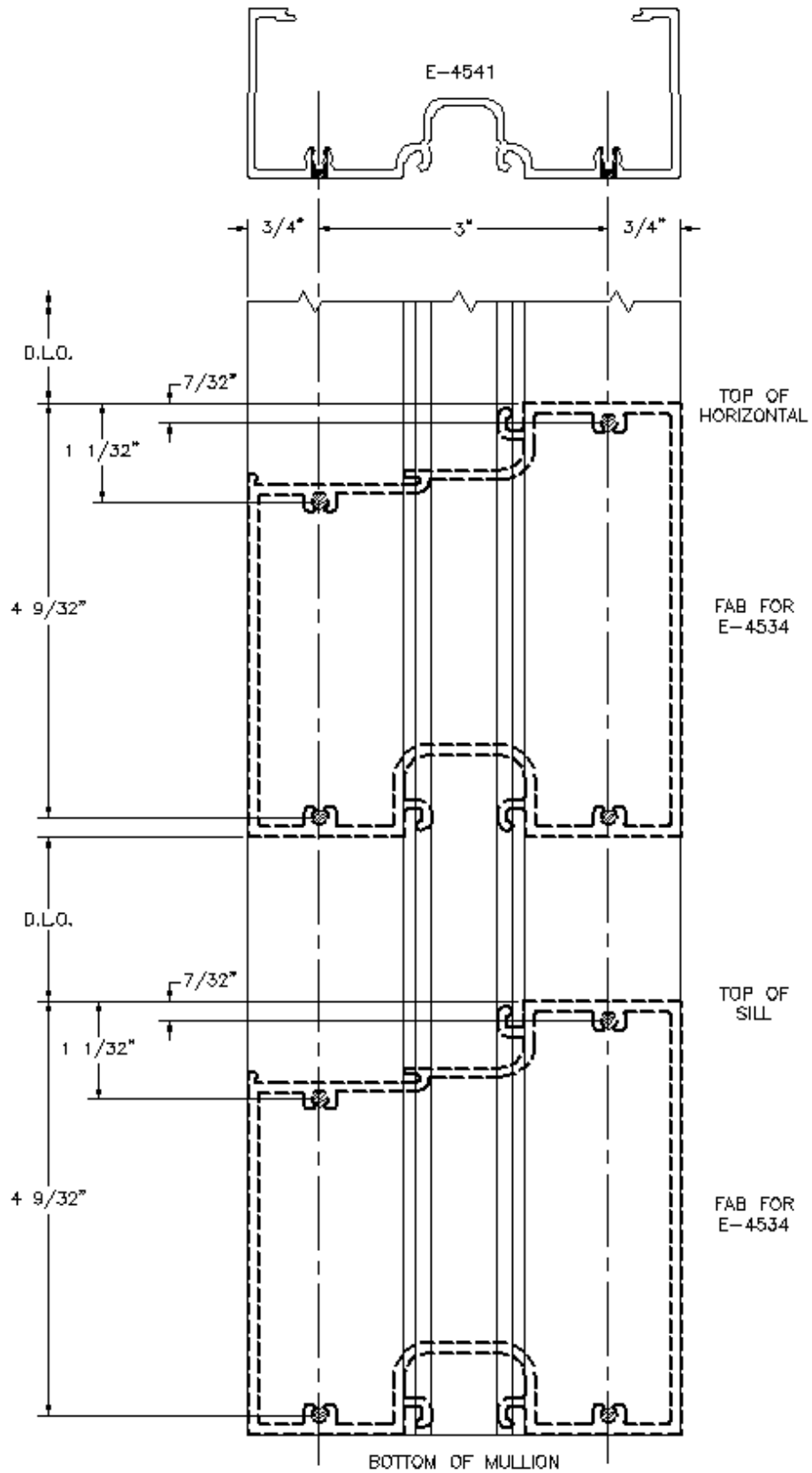

**Drilling an open-back vertical (E-4541) --
Screw-spline**

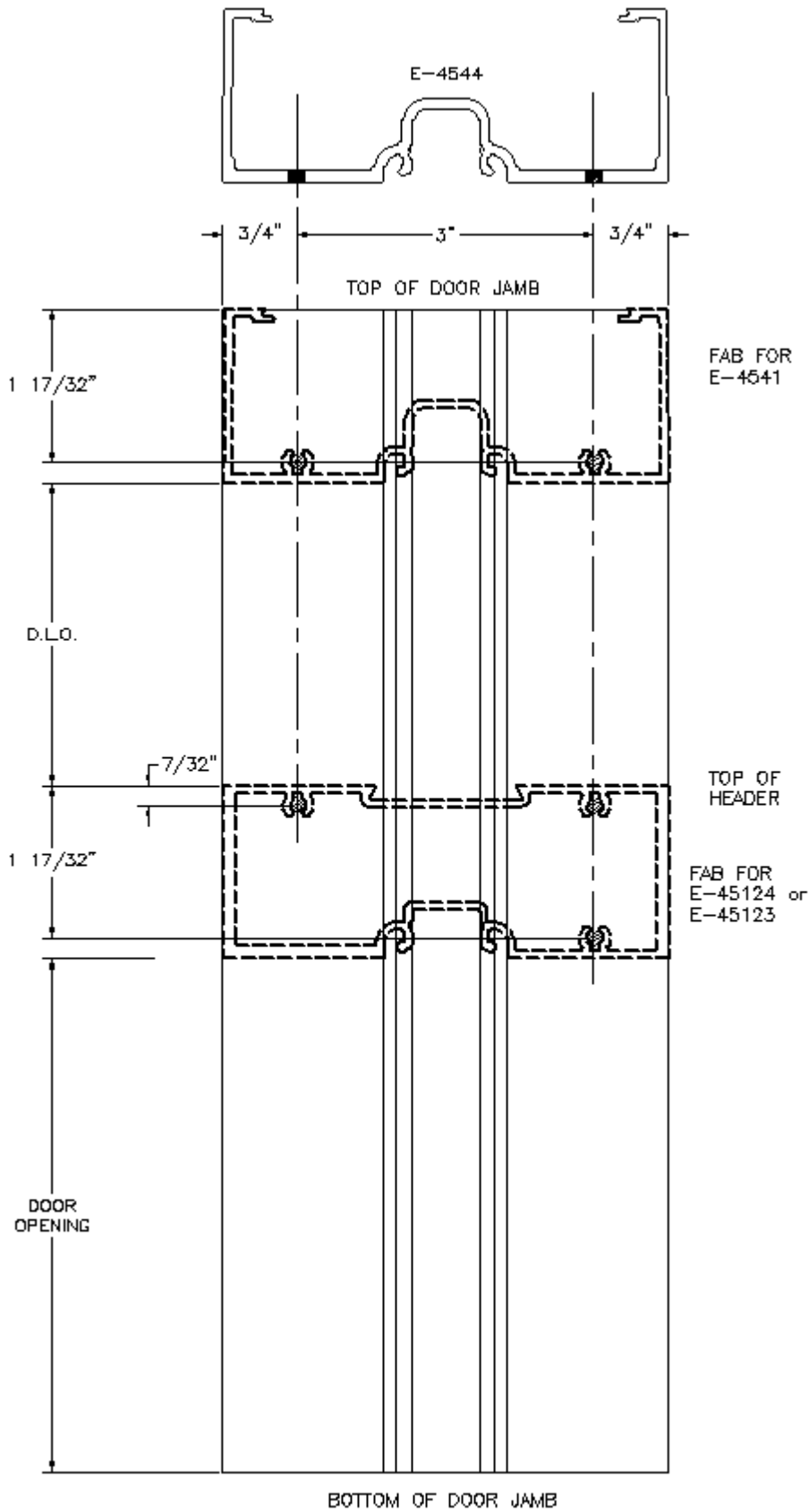

**Drilling an open-back door jamb (E-4544) --
Screw-spline, next to a door**

Step #5 (shear block assembly): Drill holes in vertical framing members

In screw-spline assembly, screws pass through holes in the vertical members, connecting them directly to the horizontal members. In shear-block assembly, the installer

- Secures frame clips (also known as shear blocks) to the vertical members with screws;
- Slides the horizontal members over the frame clips; and finally
- Secures the horizontal members to the frame clips with screws.

The screws used to secure frame clips to verticals require use of a #25 drill (.149" diameter). Tubelite recommends using a drill fixture (P796B) to facilitate quick and accurate drilling of holes in verticals for shear-block assembly projects. The following two illustrations show where to drill shear-block verticals to accommodate various types of horizontal framing members.

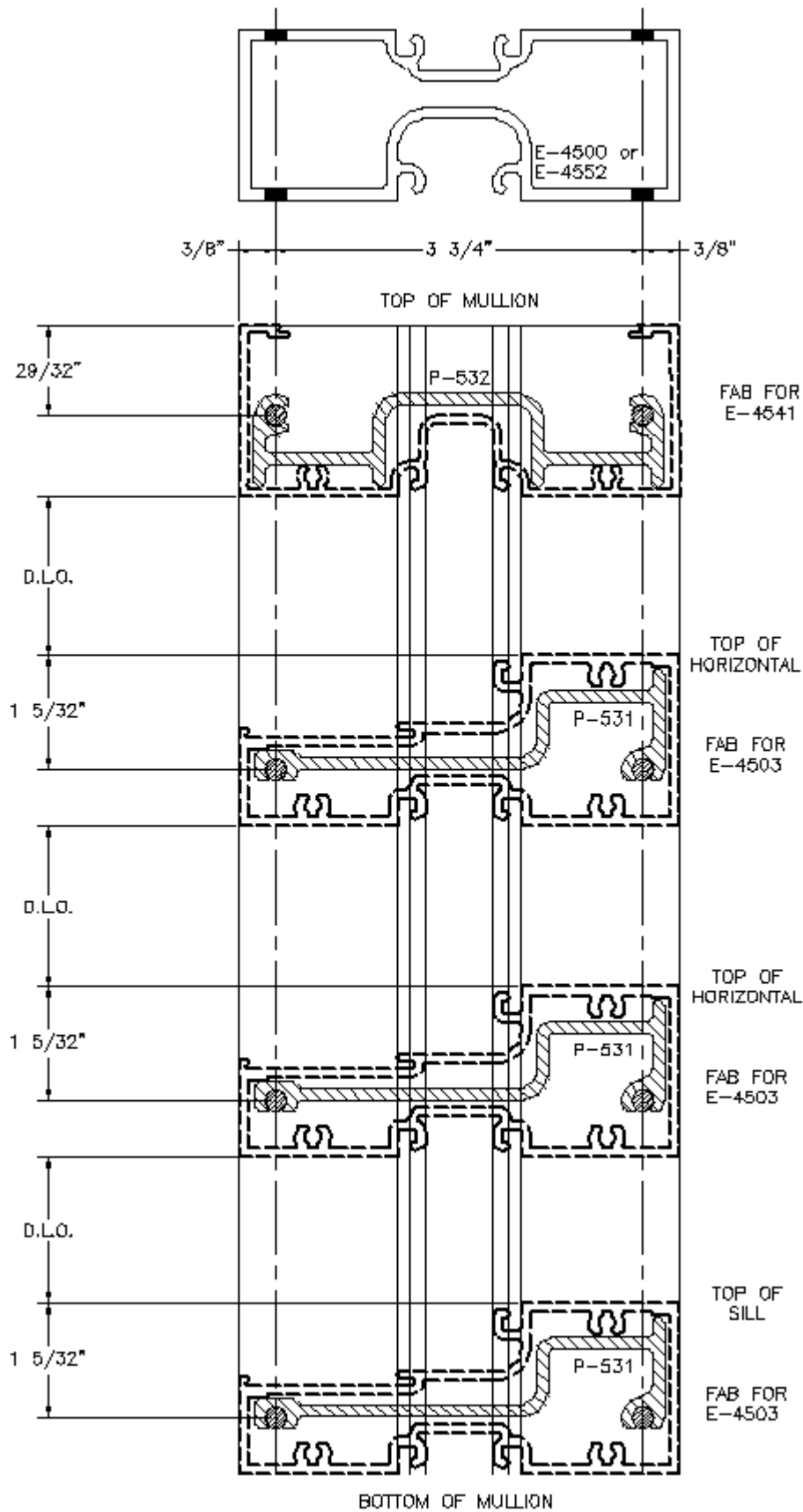

**Drilling an intermediate vertical (E-4500) --
Shear-block, no door or sidelight**

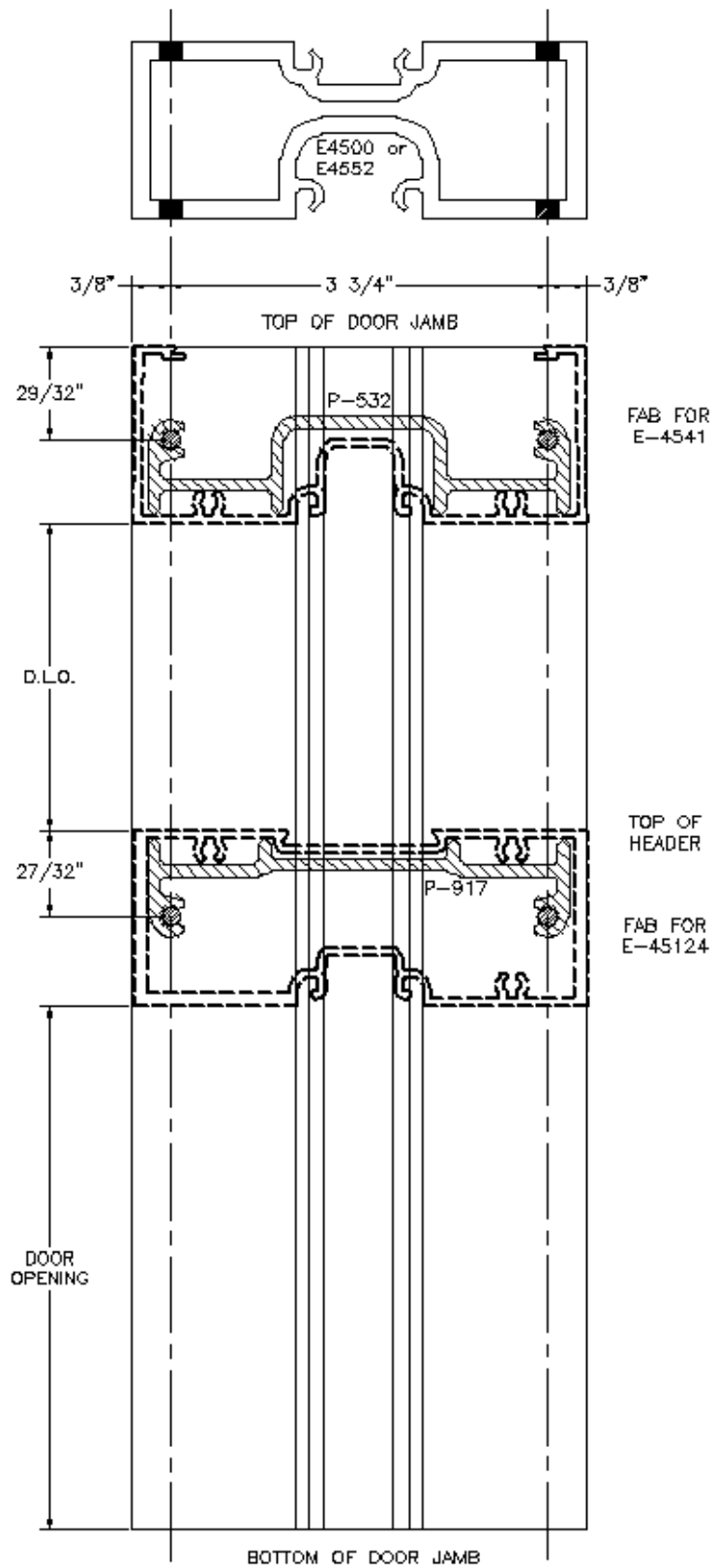

**Drilling a door jamb (E-4552) --
Shear-block, next to a door**

Step #6 (shear-block assembly): Drill holes in horizontal framing members

Screw-spline assembly does not require drilling of horizontal framing members, because screw splines are integral to the extrusions for horizontals. The shear block assembly method, on the other hand, requires drilling of horizontals, so that they can be screwed to frame clips (shear blocks).

The illustrations in this section show the locations where holes must be drilled in the various kinds of horizontals for use in shear-block assembly. The illustrations also show the required drill sizes, because the shear-block assembly method uses screws of two different diameters to secure horizontals to frame clips.

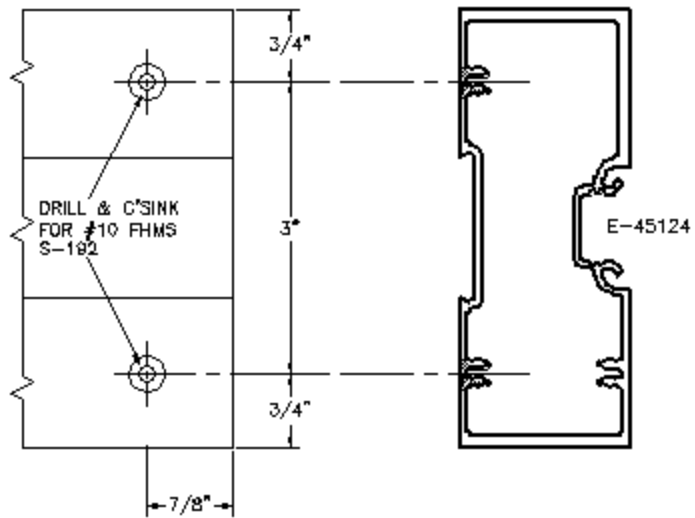
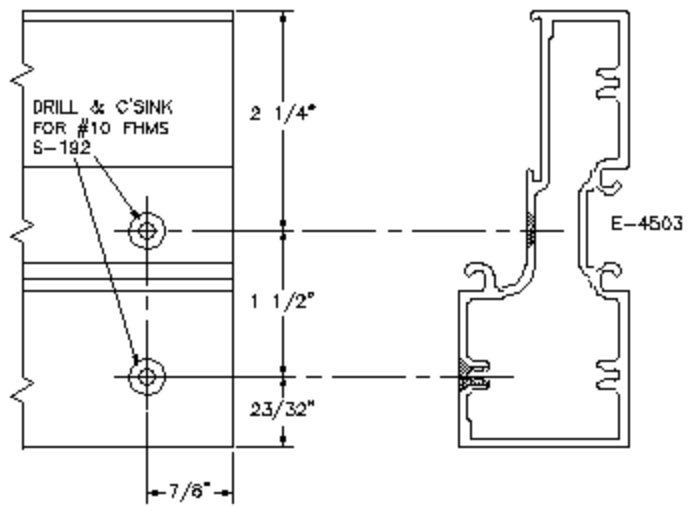
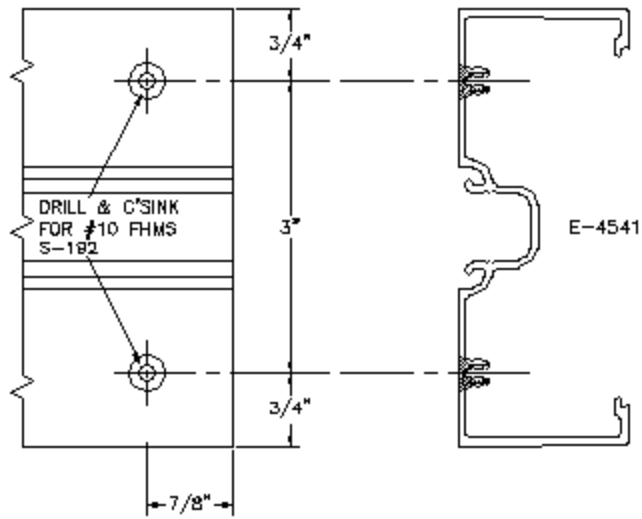

**Drilling horizontals --
Shear-block, no door or sidelight**

FRAME INSTALLATION

If there is an entrance, you should install it first, taking care to locate the entrance frame accurately within the opening.

Step #1 : Splice the flashing where required per the final distribution dwgs.

- Place the flashing in the opening. The gap between any two pieces of flashing should be $3/8''$ to $1/2''$ wide.
- Attach the splice (P-1144) to the back of one piece of flashing with double-faced tape.
- Apply silicone sealant between the two pieces of flashing, spanning the splice.
- Apply a bead of sealant from end to end of the back leg of flashing, right across the splice joint.

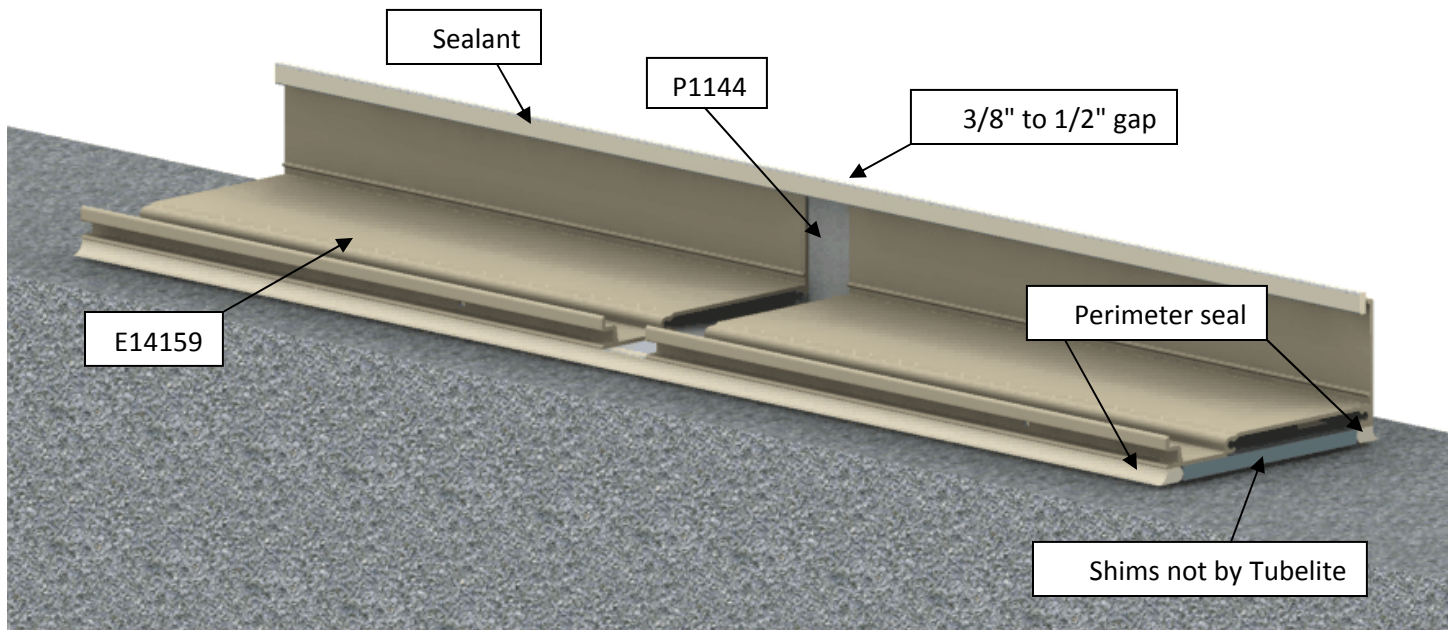

Splicing two pieces of flashing

Step #2: Seal and anchor the flashing

- Apply a full bed of sealant for an end dam and press the end dam(s) into the sealant. Seal the flashing to the end dam(s) as shown on page 24.
- Butt the flashing up against the back of the door jamb (if present), and seal the flashing to the back of the entrance frame as shown in the illustration below.
- Drill anchor holes through the flashing and into the masonry, and secure the flashing with the fasteners shown in the approved shop drawings.
- Cap seal the anchors with silicone sealant.

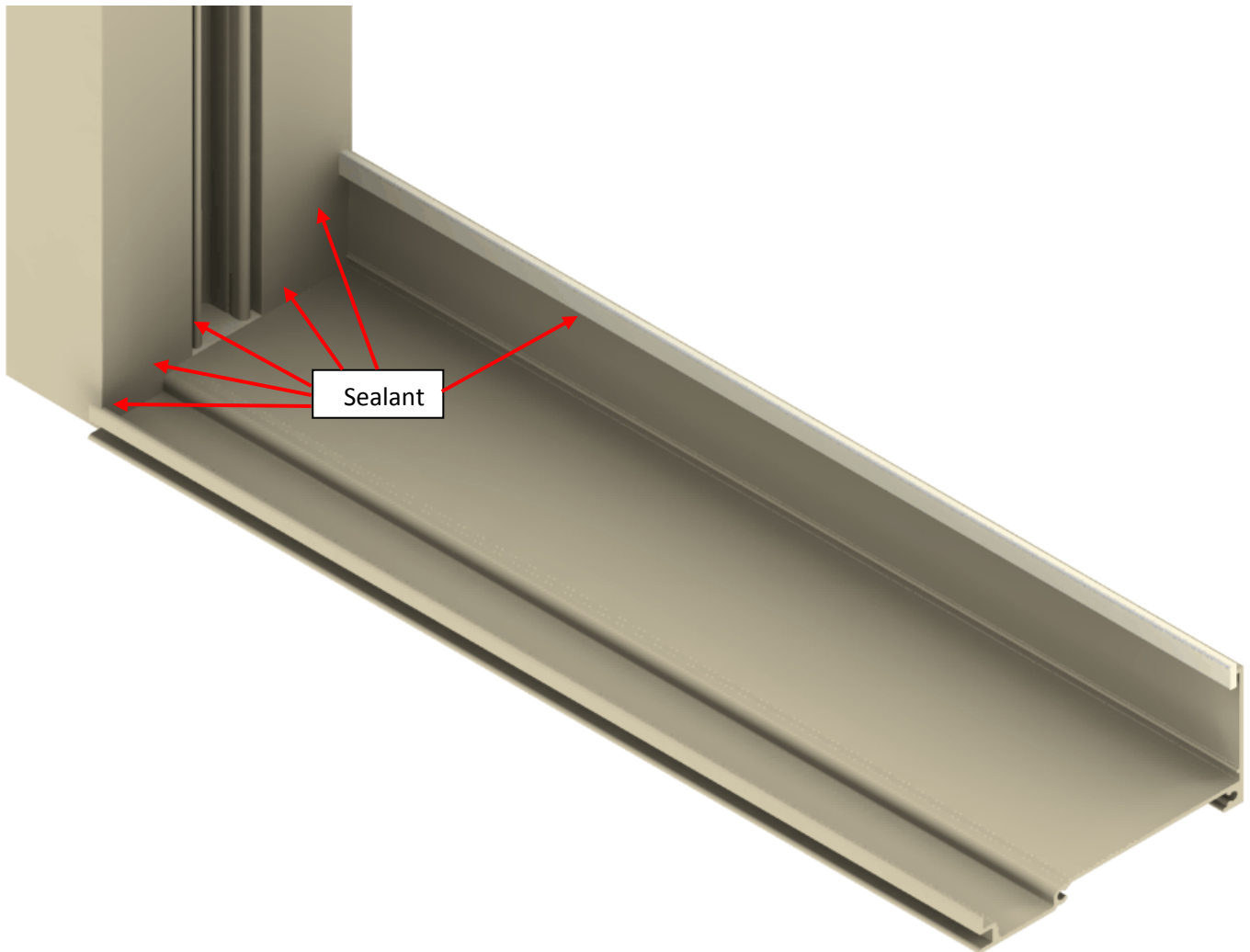

Sealing sill flashing to a door frame

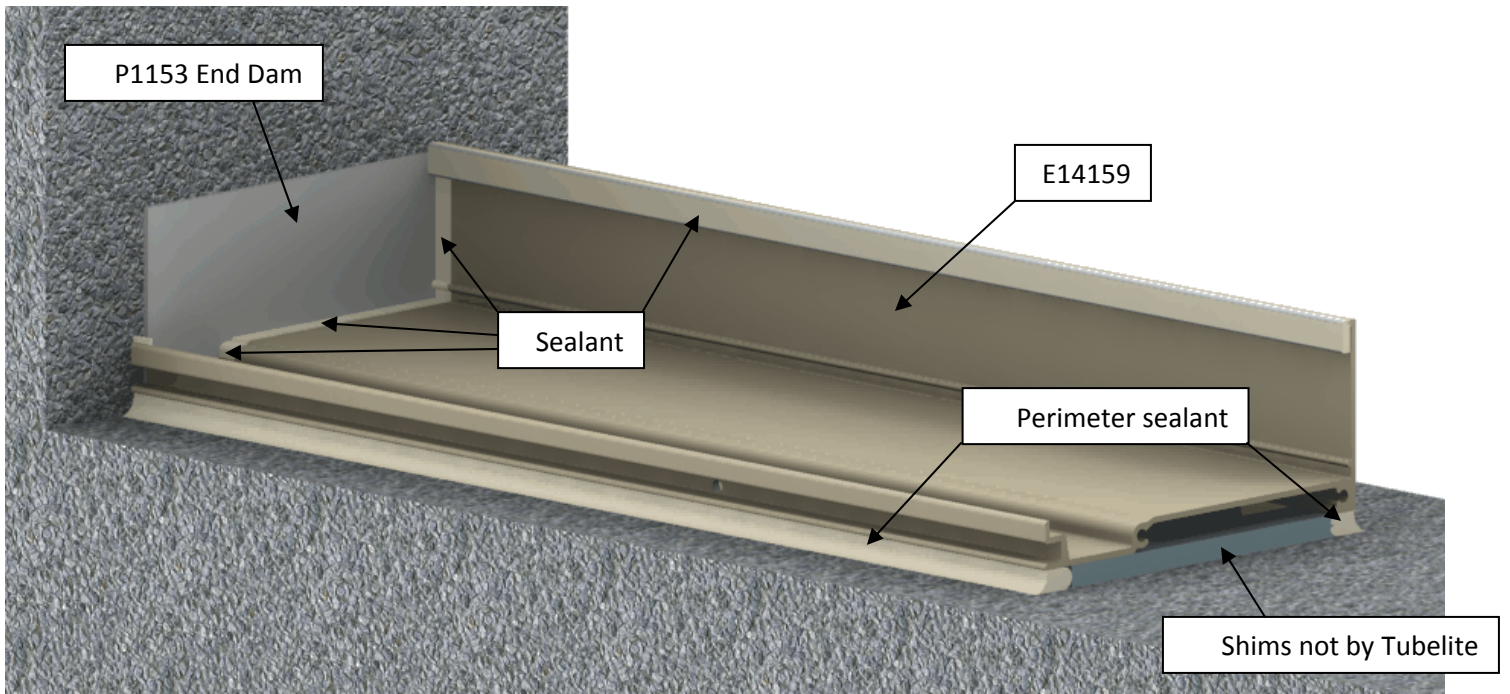

Sealing sill flashing to an end dam at a masonry wall

- Apply a bead of sealant along the back leg of the flashing from end to end, straight across any splice joint. (See splicing illustration on page 222).

Step #3 (shear block only): Seal and secure frame clips to verticals

- Apply sealant to shear blocks (frame clips) as shown in the illustration below, and attached to the verticals with #10 x 1 3/4" Type B Phillips pan head screws (S-009).

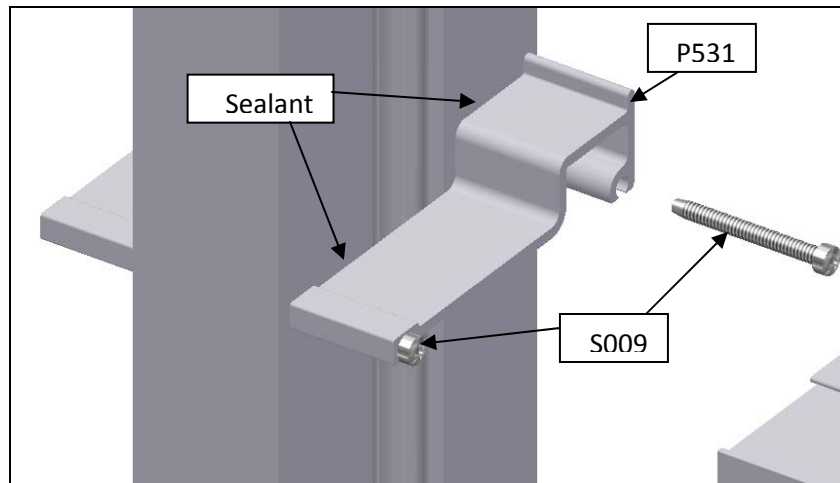

Sealing and securing frame clips to verticals

Step #4 (shear block only): Attach horizontals to frame clips

- Apply sealant to the contact edge of the horizontal, as shown in the illustration below.

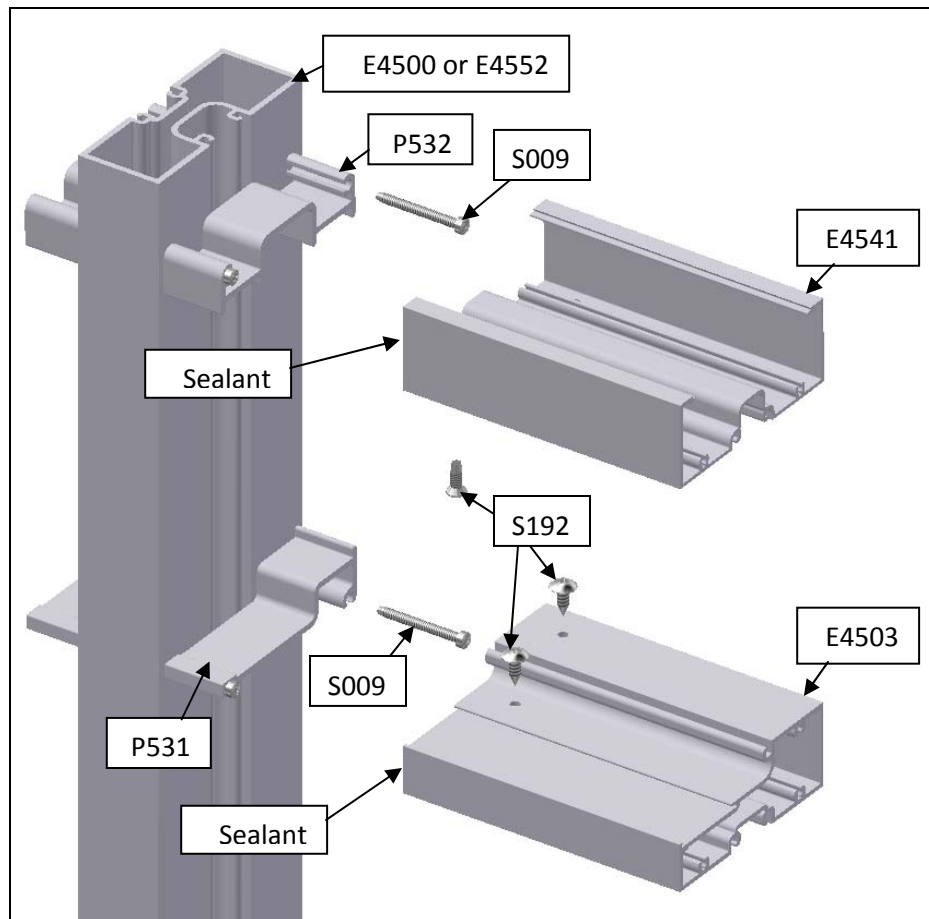

Attaching horizontals to frame clips

- Slide horizontals onto shear blocks (frame clips). Match drill tap holes in the shear blocks using holes in horizontals as guides, and secure horizontals to frame clips with #10 x 5/8" Phillips flat head screws (S-192).
- Apply sealant to the heads of the screws which secure the horizontals to the frame clips.

Step #3 (screw spline only): Attach horizontals to verticals

- Apply sealant to the contact edges of the horizontal as shown in the illustration below and on page 27.

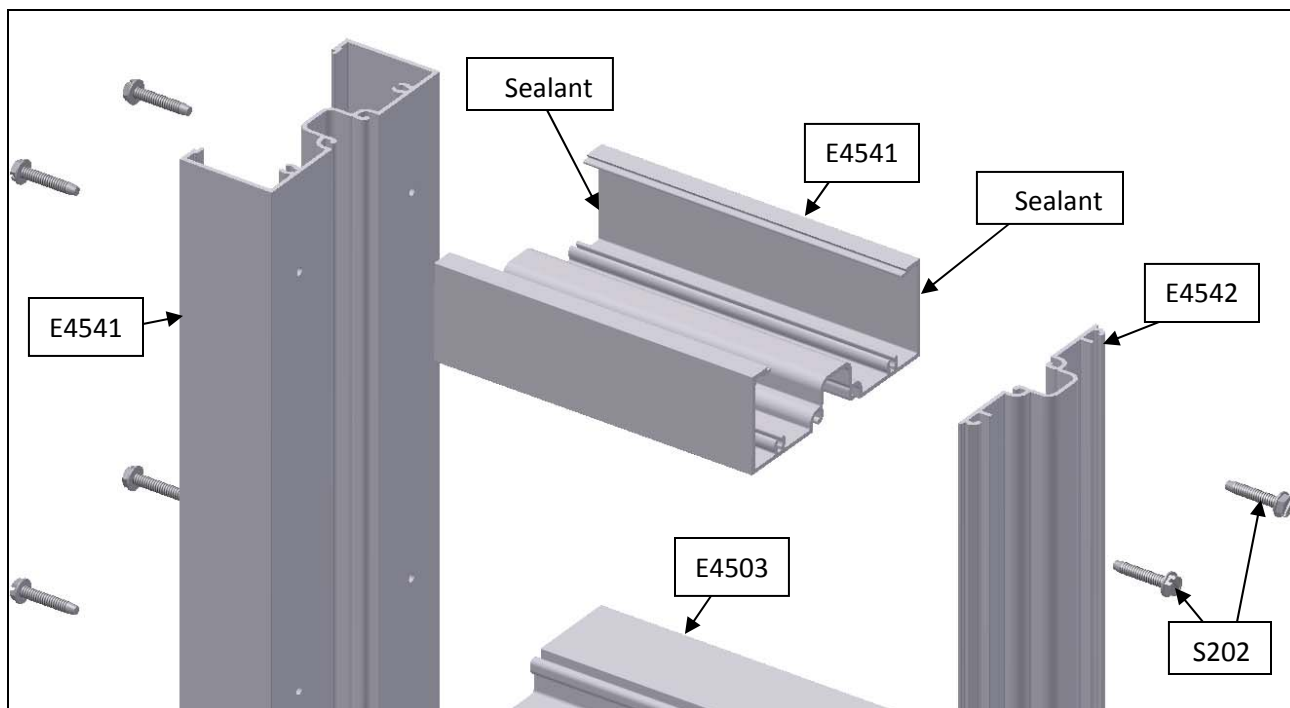

Attaching horizontals to verticals

- Secure horizontals to vertical on one side, and to closure pocket on the other side, using #10-24 x 1" Type 23 Phillips hex head screws (S-202).

Step #4 (screw spline only): Install assembled units

- Apply sealant to end of horizontal as shown in the illustration below.

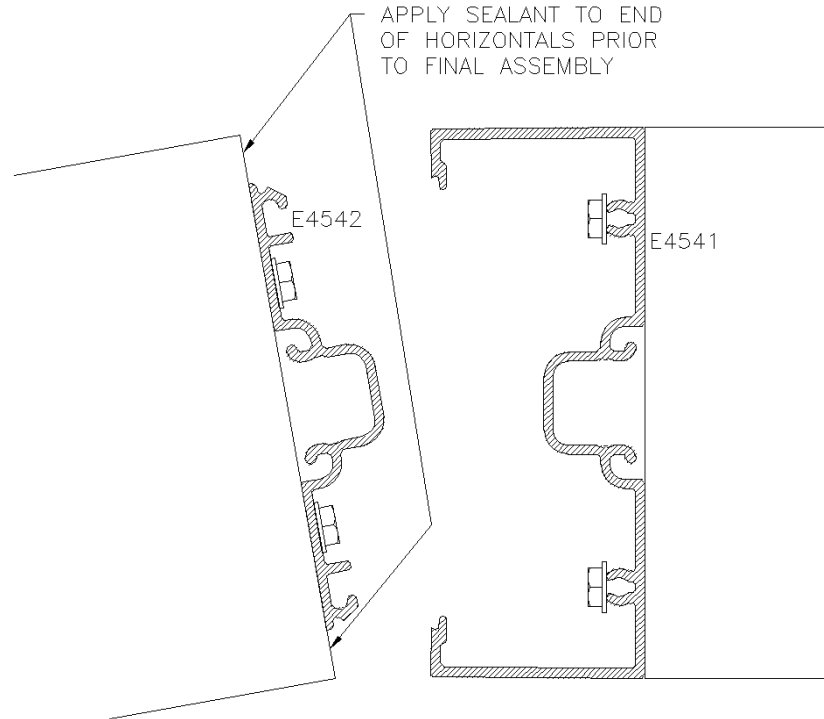

Sealing horizontal before final assembly

- Install the assembled units beginning at the entrance, and working toward the jambs. If there is no entrance, begin at one jamb and work toward the other, as in the illustration below.

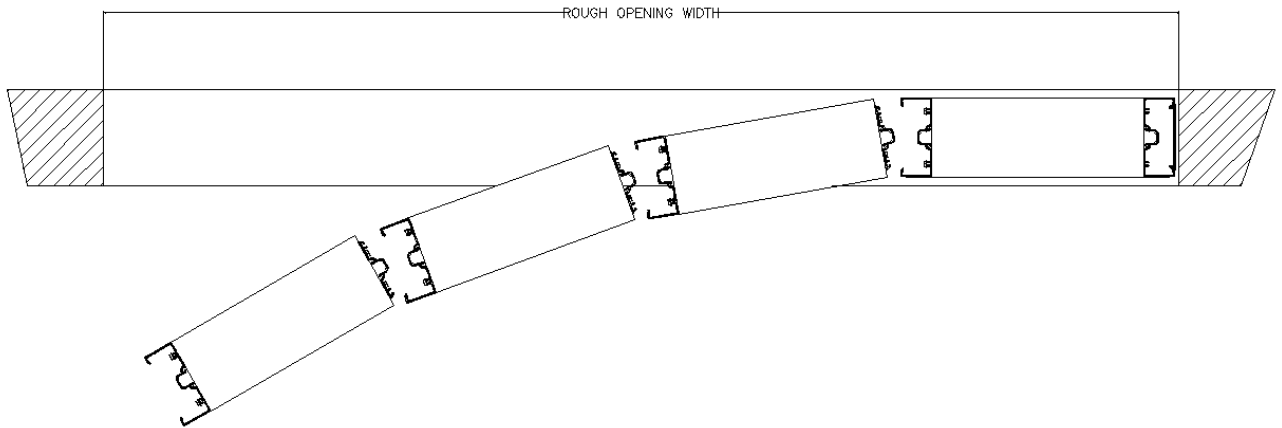

Installing assembled screw-spline units

- In the case of smaller units, the last two may need to be snapped together and then pivoted into position together, as in the illustration on page 28.

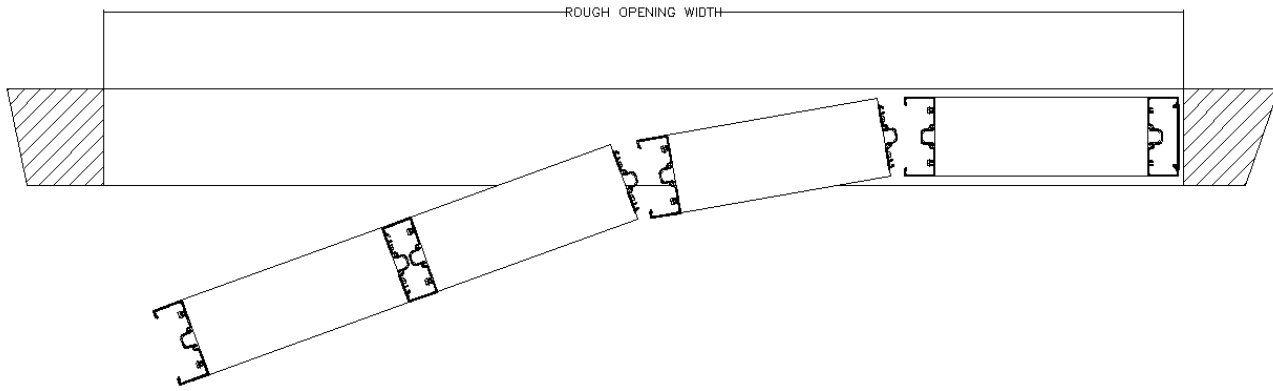

Installing last two units together

Step #5: Attach frame to masonry

- For shear-block assembly, set the assembled unit into the opening. (For screw-spline assembly, this was done in pieces in Step #4 above.)
- Install shims at head and jambs, as shown in the illustration below. Use a P1745 to provide back-up support for shimming.

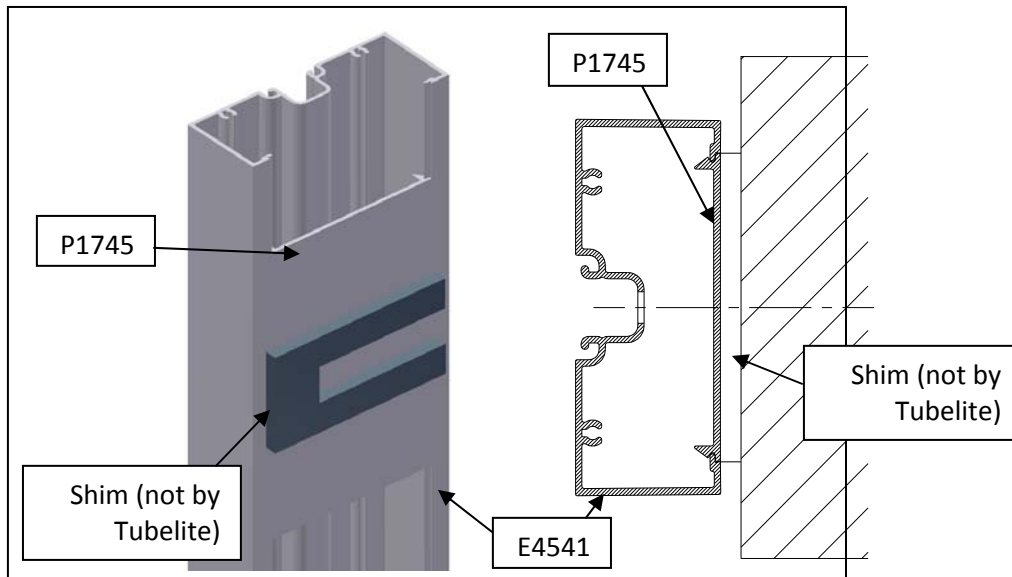

Shimming and anchoring the head and jambs

- Attach the jambs and head to the perimeter of the opening with suitable fasteners.

Step #6: Install P878 water diverters

- Use MEK and a clean cloth to clean the surfaces of the horizontals where you will install water diverters. (See illustrations below.) Also clean the vertical reglets on both sides to at least 1” above the gasket reglets on the horizontal member.

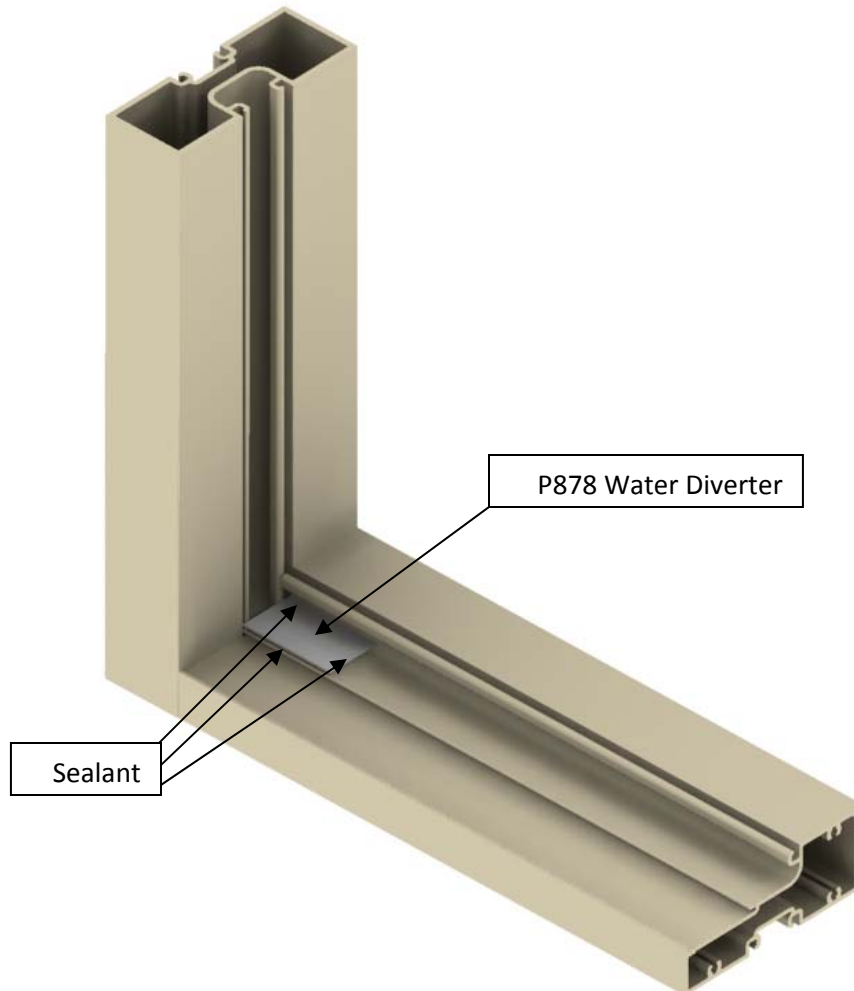

Water diverter -- 3D view

- When the surfaces are dry, peel the paper backing off the water diverter and attach the diverter to the horizontal in the glazing pocket.
- Pump sealant into both vertical gasket reglets, and seal the edges of the diverter on all sides **EXCEPT** at the drip bend. You must avoid getting sealant in this area in order to allow the system to drain.
- Seal the joint between the vertical and horizontal members from the diverter to the top of the horizontal gasket reglet.

GLAZING INSTALLATION

Glass dimensions should not exceed day light opening (D.L.O.) plus 5/8". See illustration below.

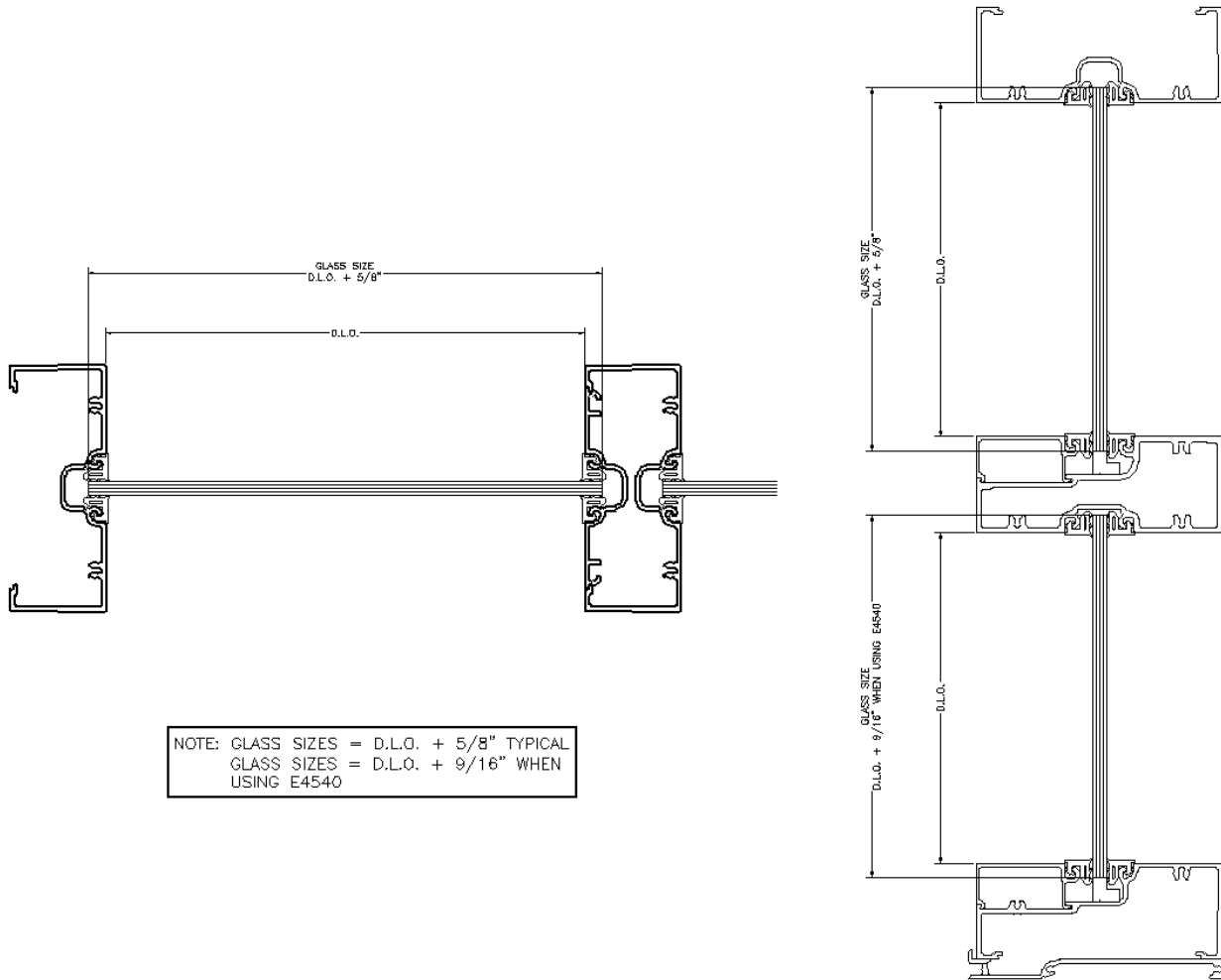

Nominal glass dimensions

This formula does not take into account out-of-square openings or glass tolerances. Consult your glass manufacturer before determining final glass sizes.

When cutting gaskets, you should add 1/16" to 1/8" per foot of daylight opening for shrinkage. (An eighth of an inch per foot is approximately 1%.) Open, unsealed gasket joints are a potential source of leakage, and water damage to interior finishes.

When installing gaskets, always begin at the ends of the gasket and work toward the center.

Step #1: Cut and install the interior gaskets

- Cut interior vertical gaskets to D.L.O. + 1" + shrinkage allowance (see above).
- Install the interior vertical gaskets, beginning 1/2" beyond the surfaces of the adjacent horizontal framing members.
- Apply butyl sealant to the interior vertical gaskets, where the horizontal gaskets will contact them.

- Cut the interior horizontal gaskets to D.L.O. + shrinkage allowance (see page 30).
- Install the interior horizontal gaskets, pressing their ends into the butyl sealant and up against the vertical gaskets.

Step #2: Install the glass

- Position the glass in the frame.
- Raise the glass off the bottom horizontal, and place a setting block (P-575) at each quarter point (2 setting blocks per light).
- Lower the glass onto the setting blocks.

Step #3: Cut and install the exterior gaskets

- Cut the exterior vertical gaskets to D.L.O. + 1" + shrinkage allowance (see page 30).
- Install the exterior vertical gaskets. The vertical gasket should start 1/2" above the surface of the upper horizontal, and should extend 1/2" below the surface of the lower horizontal.
- Apply butyl sealant to the vertical gaskets where the ends of the horizontal gaskets will contact them.
- Cut the exterior horizontal gaskets to D.L.O. + shrinkage allowance (see page 30).
- Install the exterior horizontal gaskets, pressing their ends into the butyl sealant and up against the vertical gaskets.

Step #4: Seal perimeter of installation

- Insert backer rod into the gap between the frame and the building substrate on top, sides, and bottom of the installation.
- Apply sealant to fill the void.
- Tool the sealant smooth.

TUBELITE®

STOREFRONT, CURTAINWALL & ENTRANCES

DEPENDABLE

Tubelite Inc.

3056 Walker Ridge Drive NW, Suite G
Walker, Michigan 49544

Phone 800.866.2227

Fax 877.299.2414

www.tubeliteinc.com