

# Versa-Therm

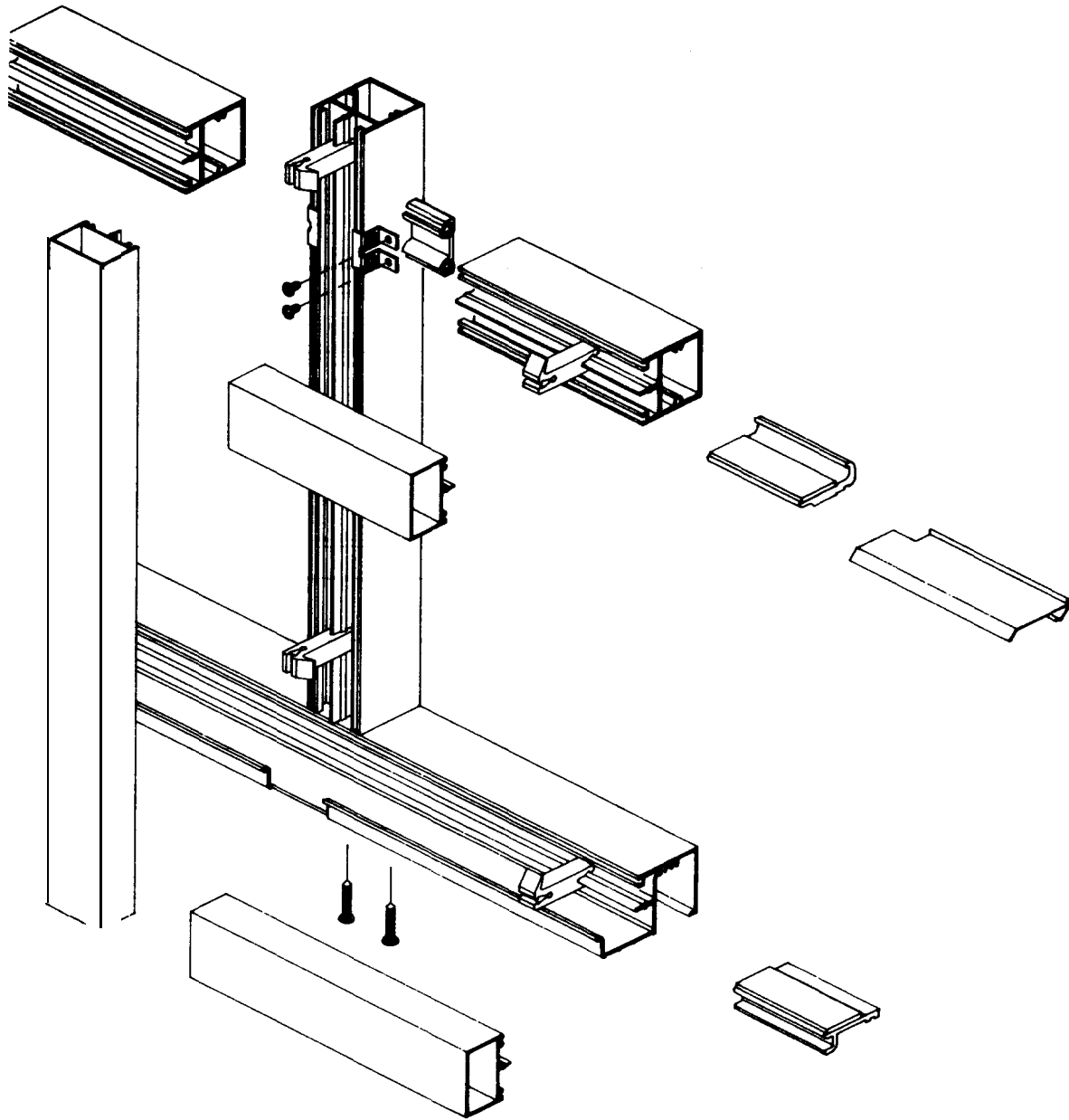









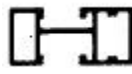

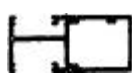
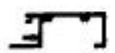









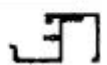

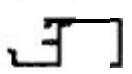













## Installation Instructions



# TUBELITE

# Table of Contents

Page	Description
1	Parts list
2	Typical elevation & cut lengths
3	General construction notes
4	General installation notes
5	Typical jamb assembly
6	Typical intermediate assy
7	Typical Roll-over Mullion assy
8	Typical splice detail and High performance mullion assembly
9	Typical Structural mullion assy
10,11	Typical adaptation to Stock Door and Frame
12,13,14	Typical Thermal Door Frame
15	Typical Horizontal Details
16	Typical Vertical Details
17	Glazing combinations

DESCRIPTION	PART NO.	DESCRIPTION	PART NO.
 9/16" PERIMETER	E-2879	 4 1/2" CENTER SET H. P. INTERMEDIATE	T-2892
 1 15/16" PERIMETER	E-2880	 4 1/2" FRONT SET H. P. INTERMEDIATE	T-2878
 2 15/16" PERIMETER	E-2861	 4 1/2" DOOR JAMB (WT-2885 ADAPTER)	T-2864
 3/16" FACE	E-2862	 STOCK FRAME ADAPTER	E-2882
 15/16" FACE	E-2877	 1/4" GLASS REDUCER	E-2867
 1 3/16" FACE	E-2863	 1" CLOSURE	E-2866
 1 15/16" FACE	E-2878	 STANDARD GASKET (USE BOTH SIDES)	P- 1863
 1 15/16" PERIMETER	E-2866	 WEDGE (USE ON FIXED POCKET MEMBERS AND OPTIONALLY ON EXTERIOR)	P-1112
 2 15/16" PERIMETER	E-2858	 1/4" GLAZING SHELF FOR 1-1/4" SYSTEM	P- 1678
 6" PERIMETER	E-2898	 1" GLAZING SHELF FOR INTERMEDIATES & 1-1/4" SYSTEM	P-1677
 3/16" FACE	E-2857	 PERIMETER SHELF FOR 1-3/4" SILLS	P-1679
 15/16" FACE	E-2871	 ANTI-ROTATION BLOCK	P-1875
 1 3/16" FACE	E-2859	 1 15/16" ROLL OVER SHEAR BLOCK (USE WITH E-2690)	P-1711
 1 15/16" FACE	E-2872	 2 15/16" ROLL OVER SHEAR BLOCK (USE WITH E-2855)	P-1674
 9/16" INTERMEDIATE	E-2873	 WATER DIVERTER	P-1709
 1 15/16" INTERMEDIATE	E-2874	 1/4" GLAZING CLIP	P-1707
 2 15/16" INTERMEDIATE	E-2660	 1" GLAZING CLIP	P-1708
 6" INTERMEDIATE	E-2899	 1/4" SETTING BLOCK	P- 1681
 1 15/16" ROLL OVER INT1 (W/E-2690 BACK) (USE WITH P-1711 CLIP)	E-2889	 1" SETTING BLOCK	P-1660
 2 15/16" ROLL OVER INT1 (W/E-2856 BACK) (USE WITH P-1674 CLIP)	E-2655	 'GUN SIGHT' CLIP	P-1710
 STRUCTURAL MULLION FOR 1-15/16" PERIMETER	E-2893	#10 x 1-3/4" SCREW (SHEAR BLOCKS) #10 x 1" SCREW (SCREW BOSSES) #8 x 3/8" SCREW (GUN SIGHT CLIP)	S-009 S-146 S-196
 STRUCTURAL MULLION FOR 2-15/16" PERIMETER	E-2875	DRILL FIXTURE SCREW BOSS CONNECTION) DRILL FIXTURE CLIP JOINT CONNECTION) DRILL FIXTURE BUTT GLAZE & H.P.)	P-1697 P- 1698 P-1699

# Typical elevation with cutting lengths

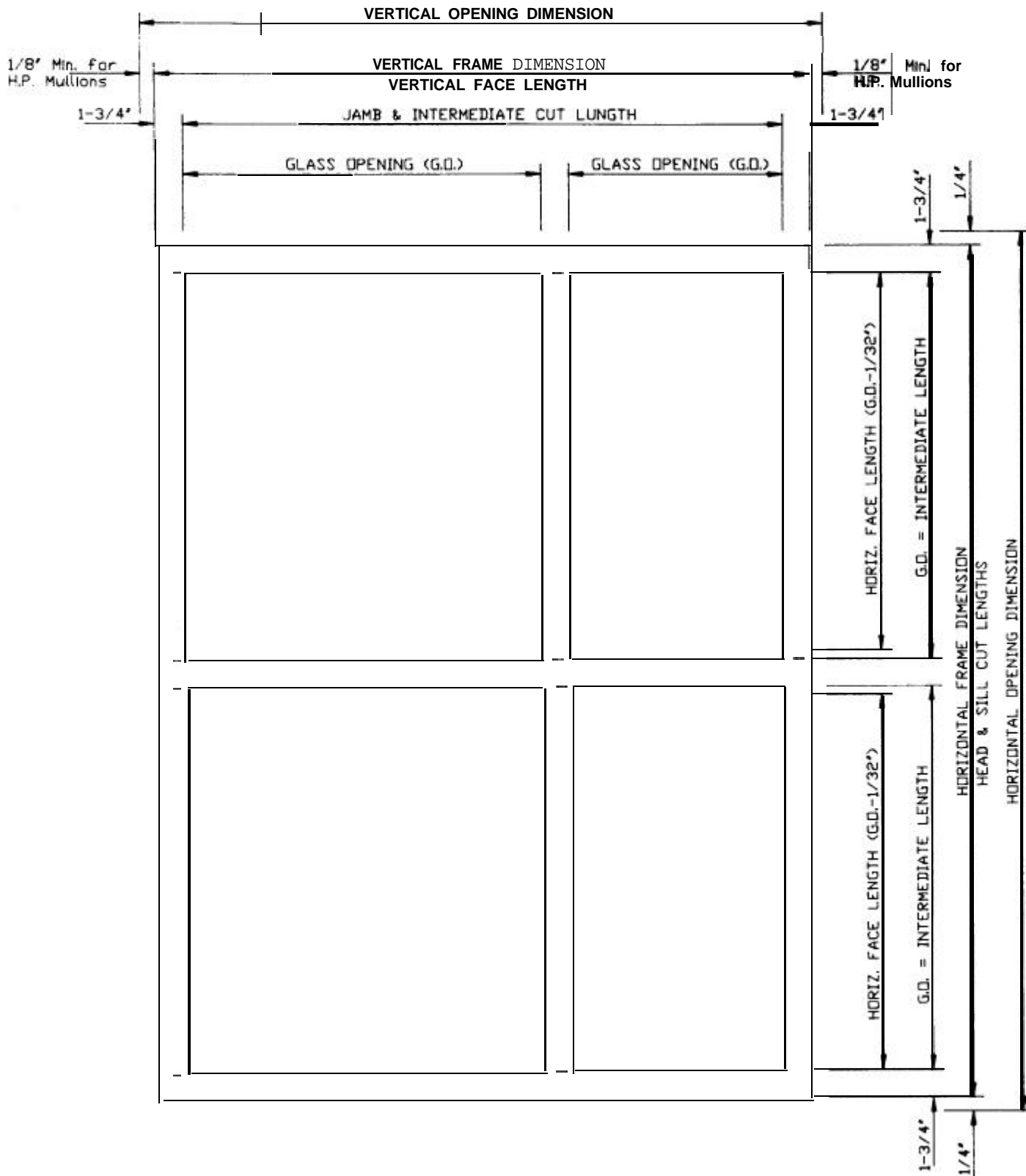

# GENERAL CONSTRUCTION NOTES

01. **These drawings and notes cover typical conditions for this project. Due to individual job requirements it is necessary to refer to Tubelite's final distribution drawings for supplemental information not covered by these instructions. Any conflict or discrepancies must be clarified through Tubelite's Engineering Department prior to execution.**
02. **Materials stored at the job site must be stored in a safe place removed from possible damage by other trades. Stack with adequate separation so materials will not rub together and store off the ground. Cardboard or paper wrapped materials must be kept dry. Check arriving materials for quantity and keep record of where various materials are stored.**
03. **All field welding must be adequately shielded to avoid any weld splatter on either aluminum or glass. Results will be unsightly and/or structurally unsound. Advise general contractor and other trades accordingly.**
04. **Coordinate protection of installed work with general contractor and/or other trades.**
05. **Coordinate sequence of other trades which affect strip window installation with general contractor (i.e. fire proofing, back up walls, partitions, ceilings, mechanical ducts, convectors etc.)**
06. **General contractor should furnish and guarantee bench marks, offset lines and opening dimensions. These items should be checked for accuracy before proceeding with erection. Make certain construction which will receive your material is according to contract documents. If not, notify the general contractor in writing before proceeding with your work. Since this constitutes acceptance of work by other trades.**
07. **Insulate all aluminum to be placed directly in contact with the masonry or other incompatible materials with a heavy coat of zinc chromate or bituminous paint.**
08. **Sealant selections is the responsibility and option of erector or glazer and must be approved by the sealant manufacturer in regard to quality and compatibility for it's intended use. All sealants must be used in strict accordance with manufacturer's instructions, applied only by trained personnel to surfaces that have been properly prepared.**
09. **Drainage gutters and weep holes must be kept clean at all times. Tubelite cannot accept responsibility for improper drainage as a result of clogged gutters and weep holes.**
10. **This product requires clearance at jambs to allow adequate expansion without tearing of perimeter seals, a 1/4" minimum.**
11. **All materials to be installed plumb, level and true with regard to established bench marks and column center lines established by the general contractor, checked by the window contractor.**

# GENERAL INSTALLATION NOTES

01. Head and sill frame members run through.
02. Vertical faces run through (cut horizontal falls  $1/32$ " short to allow for expansion).  
Exception: When using high performance mullions the HORIZONTAL faces run through.
03. When using high performance mullions (E2876 or E2892) a minimum of  $1/8$ " perimeter clearance at the head & sill is required to insure assembly of faces.
04. DO NOT CAULK FACE OUTSIDE AT SILL. (See page 8).
05. Proper glass size is determined by measuring the daylight opening and adding 1" to both the height and width.
06. For GUN SIGHT clipped intermediates over 21 sq/ft., the P-1675 anti-rotation block is required.
07. When installing faces, use a wood block (to protect finish). Position block on face over a glazing clip when striking. (HINT: Mark clip location on glass with a grease pencil).
08. Do not re-use glazing clips. Remove used clips with pliers. Use Tubelite De-glazing tool P-846 to remove exterior faces.
09. When using the E-2866 pocket closure or E-2867  $1/4$ " infill adapter, crimp the lower leg approximately S-12" on center so it will snap into glazing reglet of frame member.

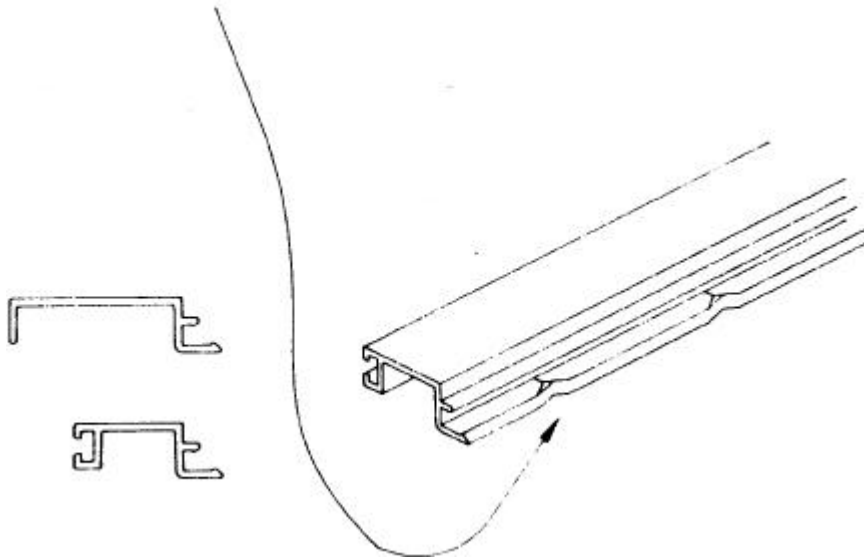

.201 DIA. THRU  
 (#7 DRILL)  
 (USE DRILL FIXTURE  
 P-1697 HOLES 1 & 2)

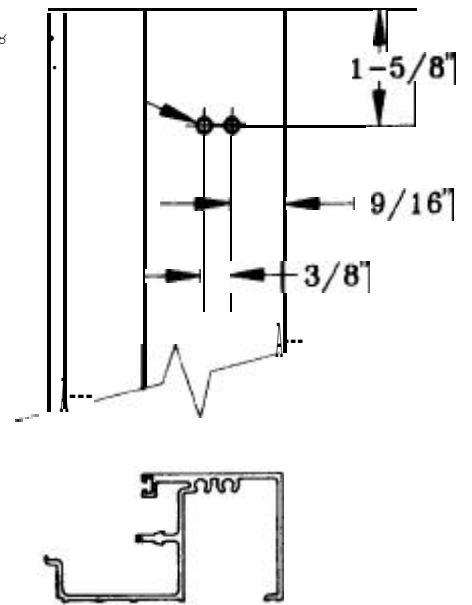

TYPICAL JAMB AT  
 SILL ASSEMBLY  
 (HEAD ASSEMBLY SIMILAR)

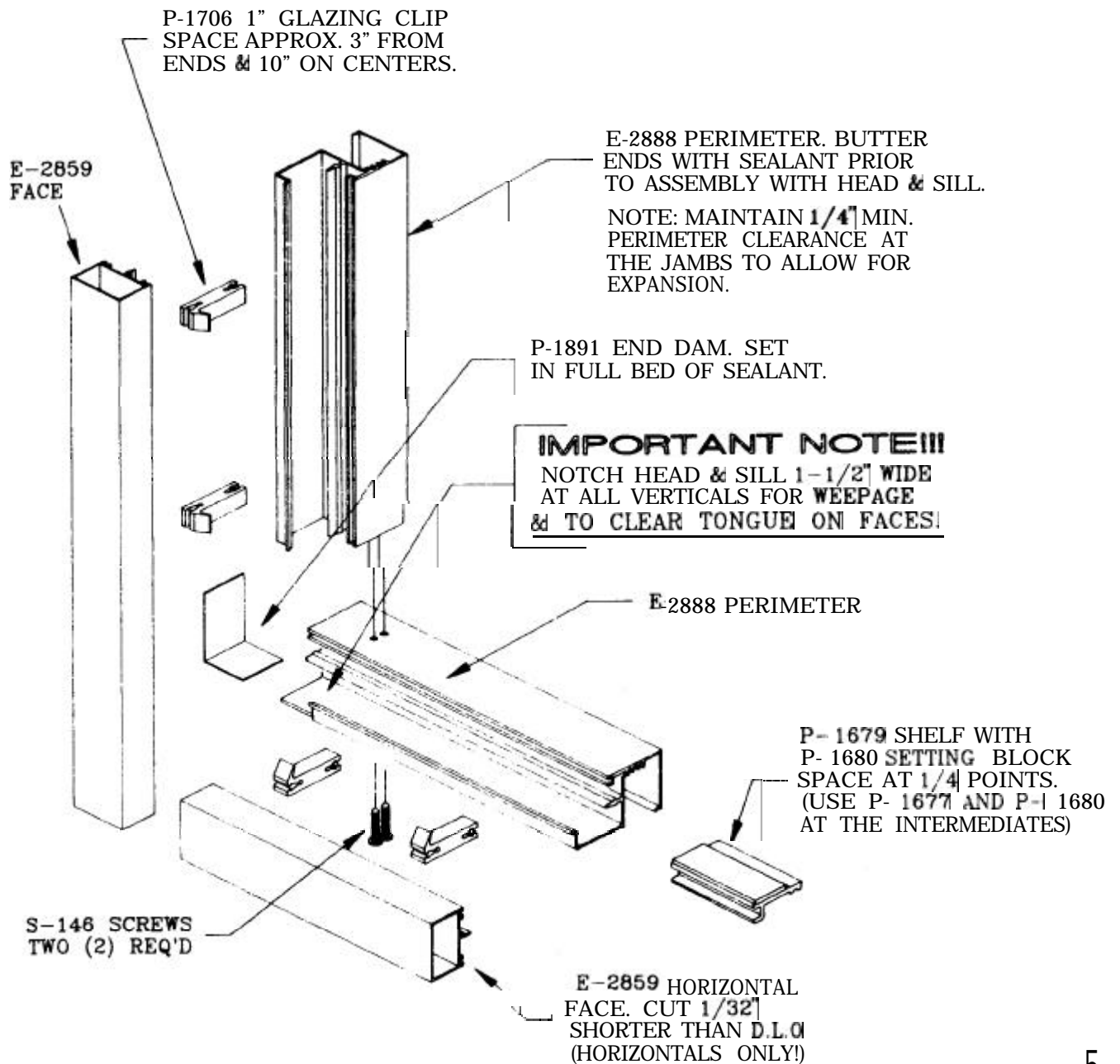

# TYPICAL INTERMEDIATE VERTICAL AT SILL ASSY

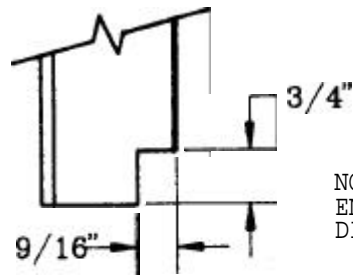

NOTE: NOTCH BOTH ENDS OF WATER DIVERTER AS SHOWN

P-1709 WATER DIVERTER SNAP IN PLACE AS SHOWN

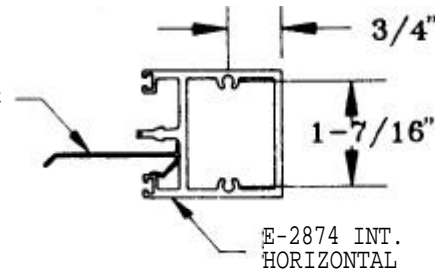

E-2874 INT. HORIZONTAL

— BUTTER ENDS PRIOR TO ASSEMBLY

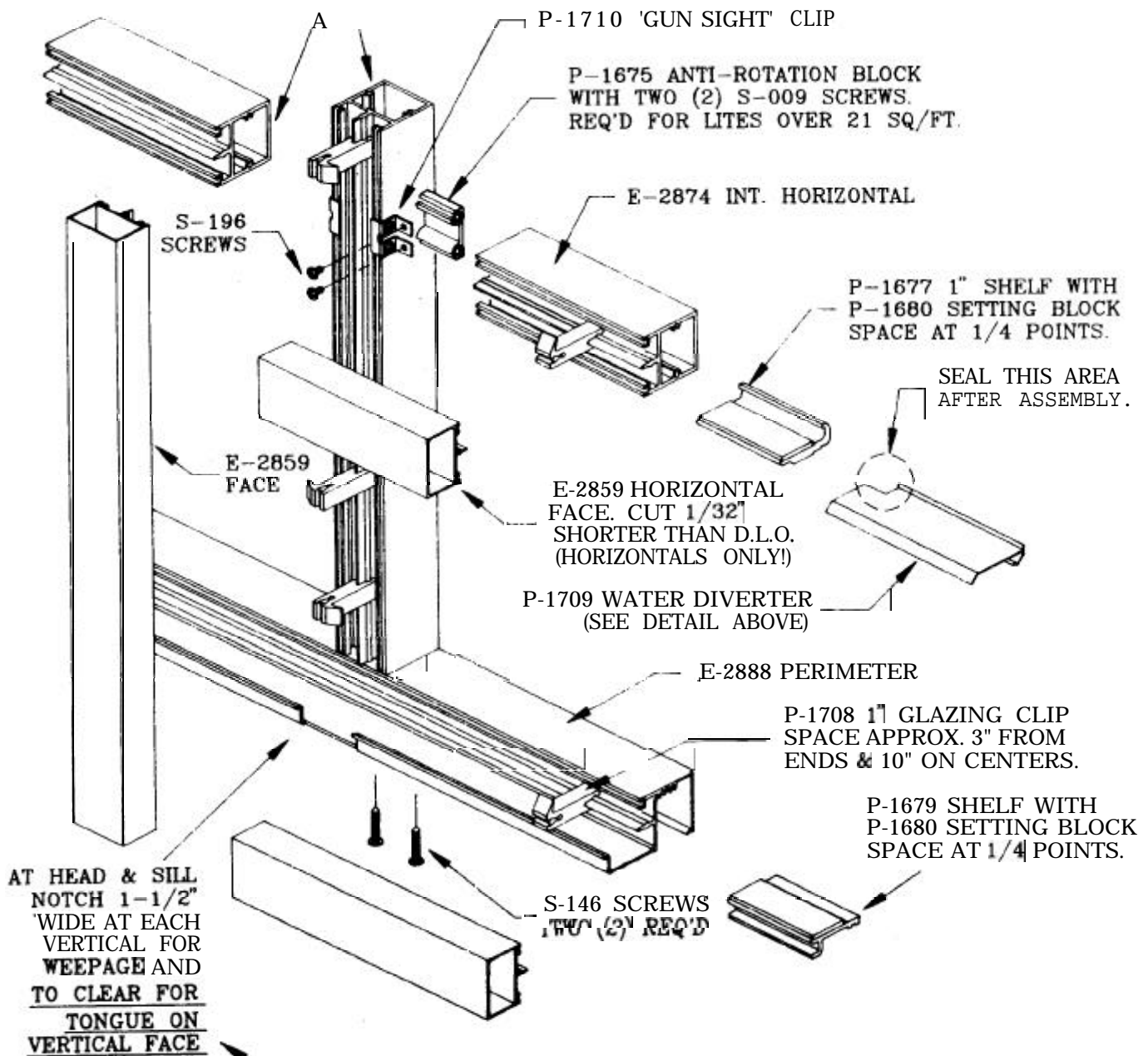

**IMPORTANT NOTE!!!**

# TYPICAL HORIZONTAL APPLICATION

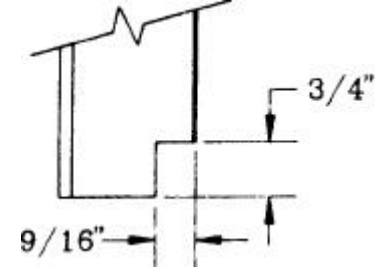

NOTE: NOTCH BOTH ENDS OF WATER DIVERTER AS SHOWN

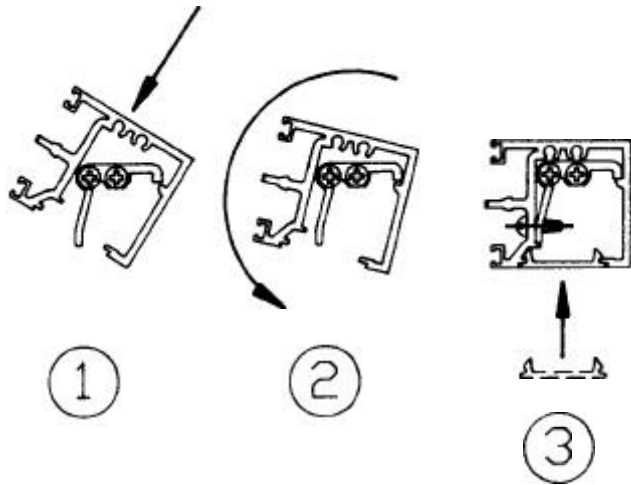

P-1709 WATER DIVERTER SNAP IN PLACE AS SHOWN

C-L OF HORIZ.

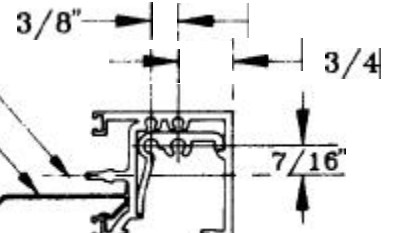

E-2889 INTL HORIZONTAL

BUTTER ENDS PRIOR TO ASSEMBLY

**NOTE: USE THE P-1112 WEDGE ON THE EXTERIOR SIDE OF THE H.P. MULLION AND P-1883 FIXED GASKET ELSEWHERE.**

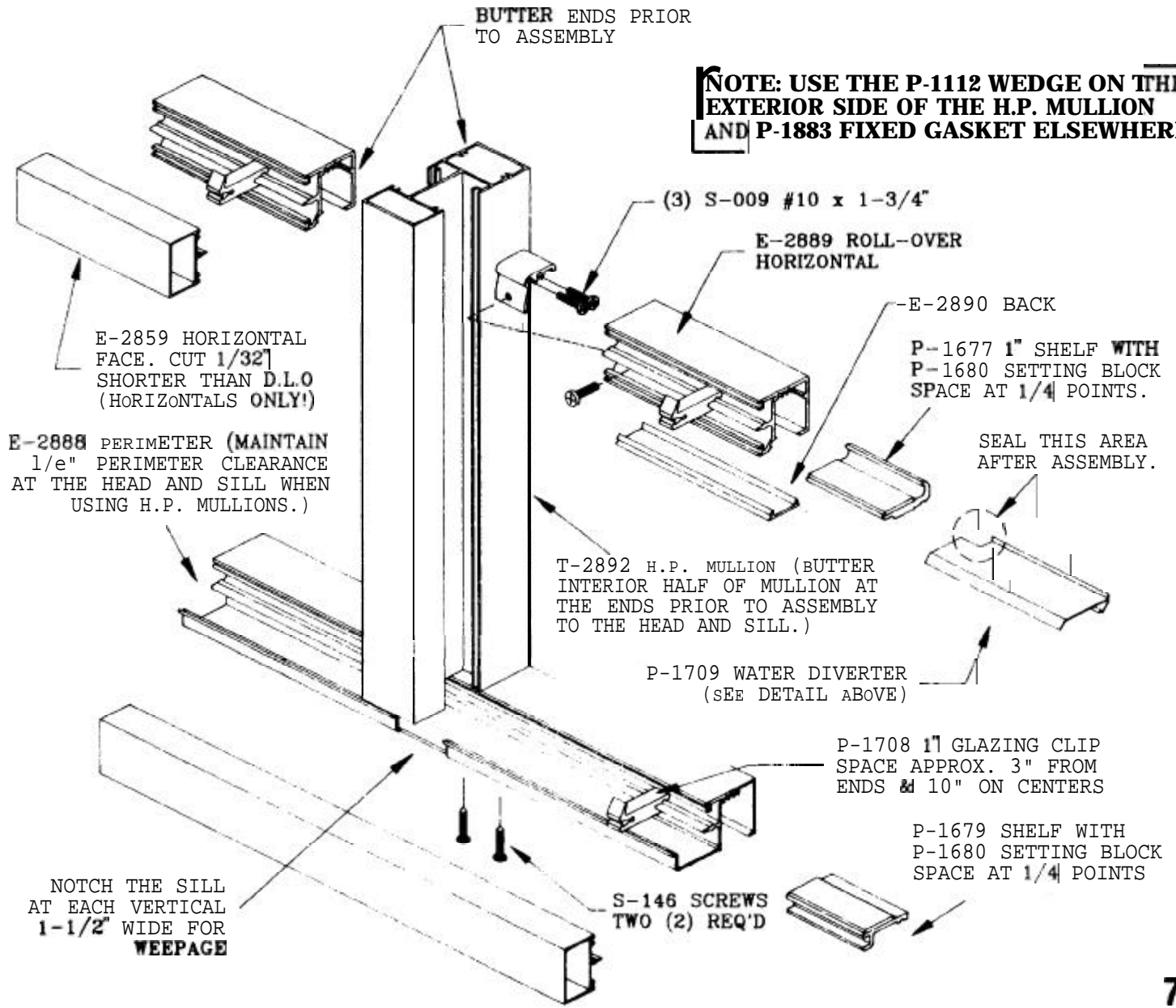

E-2859 HORIZONTAL FACE. CUT 1/32" SHORTER THAN D.L.O (HORIZONTALS ONLY!)

E-2888 PERIMETER (MAINTAIN 1/e" PERIMETER CLEARANCE AT THE HEAD AND SILL WHEN USING H.P. MULLIONS.)

T-2892 H.P. MULLION (BUTTER INTERIOR HALF OF MULLION AT THE ENDS PRIOR TO ASSEMBLY TO THE HEAD AND SILL.)

P-1709 WATER DIVERTER (SEE DETAIL ABOVE)

P-1708 1" GLAZING CLIP SPACE APPROX. 3" FROM ENDS & 10" ON CENTERS

P-1679 SHELF WITH P-1680 SETTING BLOCK SPACE AT 1/4" POINTS

S-146 SCREWS TWO (2) REQ'D

NOTCH THE SILL AT EACH VERTICAL 1-1/2" WIDE FOR **WEEPAGE**

SEAL THIS AREA AFTER ASSEMBLY.

P-1677 1" SHELF WITH P-1680 SETTING BLOCK SPACE AT 1/4" POINTS.

E-2889 ROLL-OVER HORIZONTAL

E-2890 BACK

(3) S-009 #10 x 1-3/4"

# TYPICAL HIGH PERF. INTERMEDIATE ASSY

NOTE: USE THE P-1112 WEDGE ON THE EXTERIOR SIDE OF THE H.P. MULLION AND P-1683 FIXED GASKET ELSEWHERE.

NOTCH THE HEAD & SILL WHERE EACH VERTICAL FALLS 1-1/2" WIDE FOR WEEPAGE

E-2859 FACE

T-2892 H.P. **MULLION** (BUTTER INTERIOR HALF OF MULLION AT THE ENDS PRIOR TO ASSEMBLY TO THE HEAD AND SILL.)

E-2888 PERIMETER (MAINTAIN 1/8" PERIMETER **CLEARANCE** AT THE HEAD AND SILL)

P-1708 1" GLAZING CLIP SPACE APPROX. 3" FROM ENDS & 10" ON CENTERS.

S-146 SCREWS TWO (2) REQ'D

NOTE: REMOVE APPROX. 1-1/2" OF GASKET WHERE EACH VERTICAL MULLION WOULD FALL FOR WEEPAGE.

NOTE: SECURE MULLION TO ONE (1) SIDE OF HEAD AND SILL MEMBER ONLY? USING SCREW BOSS AND ONE SET OF HOLES ON THE P-1710 'GUN SIGHT' CLIP AS SHOWN.

S-196-

P-1710 CLIP (CENTER ON FIXED SILL)

- FIXED SILL MEMBER  
FOAM BACKER ROD

-- CENTER-LINE OF MULLION

# TYPICAL SPLICE ASSEMBLY

.04" ALUMINUM SPLICE, LOCATE INTO FIXED SILL 1-1/2". ALSO, SET INTO FULL BED OF NON-CURING BUTYL BASE SEALANT.

CUT EXPANSION SILL PIECE SHORT 1/4" ON THE SPLICE END

FIXED SILL

S-146

# TYPICAL STRUCTURAL MULLION ASSEMBLY

## Installation Sequence:

1. Install perimeters & mullions.
2. Install roll-over horizontals.
3. Install P-1663 to perimeters and horizontals.
4. Install P-1709 water diverter between mullions.
5. Install glass using P-1708 glazing clips.
6. Install P-1356 temporary clip at mullions & shim with P-1680.
7. Install P-1690 spacer.
8. Apply STRUCTURAL SEAL using DOW Corning 795 silicone or equiv. per manufacturer's instructions.
9. Apply WEATHER SEAL using DOW Corning 795 silicone or equiv. per manufacturer's instructions.
10. Install face pieces with P-1683 gasket installed.

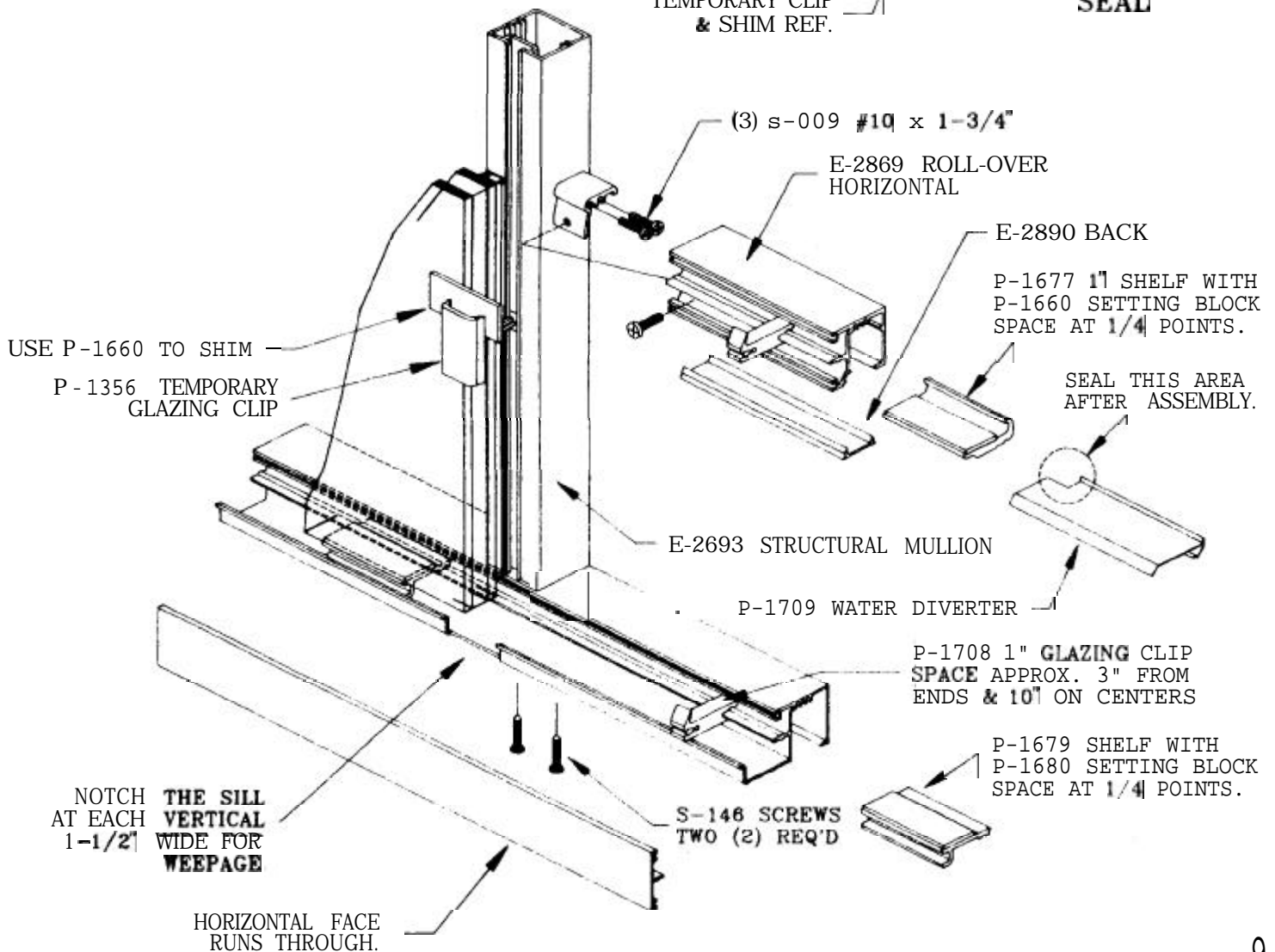
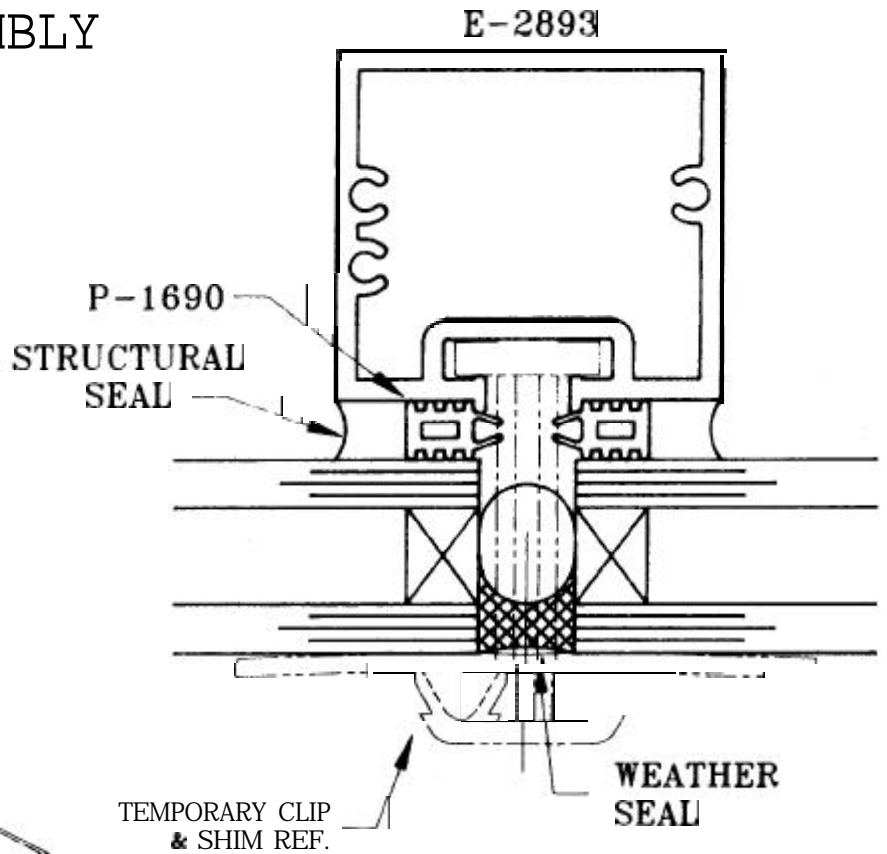

# ASSEMBLY OF STOCK DOOR PACKAGE TO VERSA-THERM

NOTE: THE FRONT LOAD SYSTEM (i.e. E2656 PERIMETER) IS NOT COMPATIBLE WITH THE STOCK FRAME. USE THERMAL FRAME (Pg. 12)

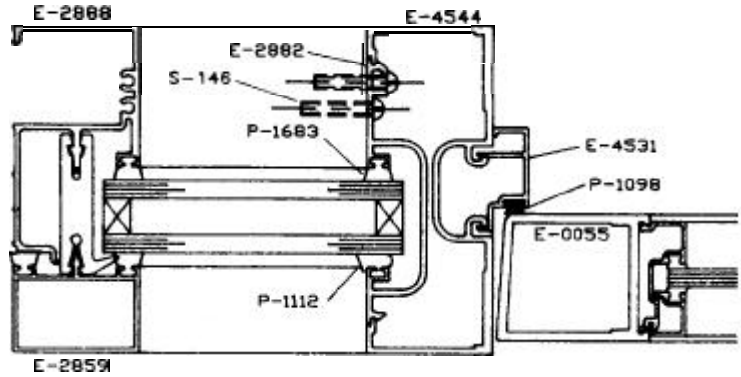

TYPICAL JAMB AT SILL ASSEMBLY (SEE PAGE 5)

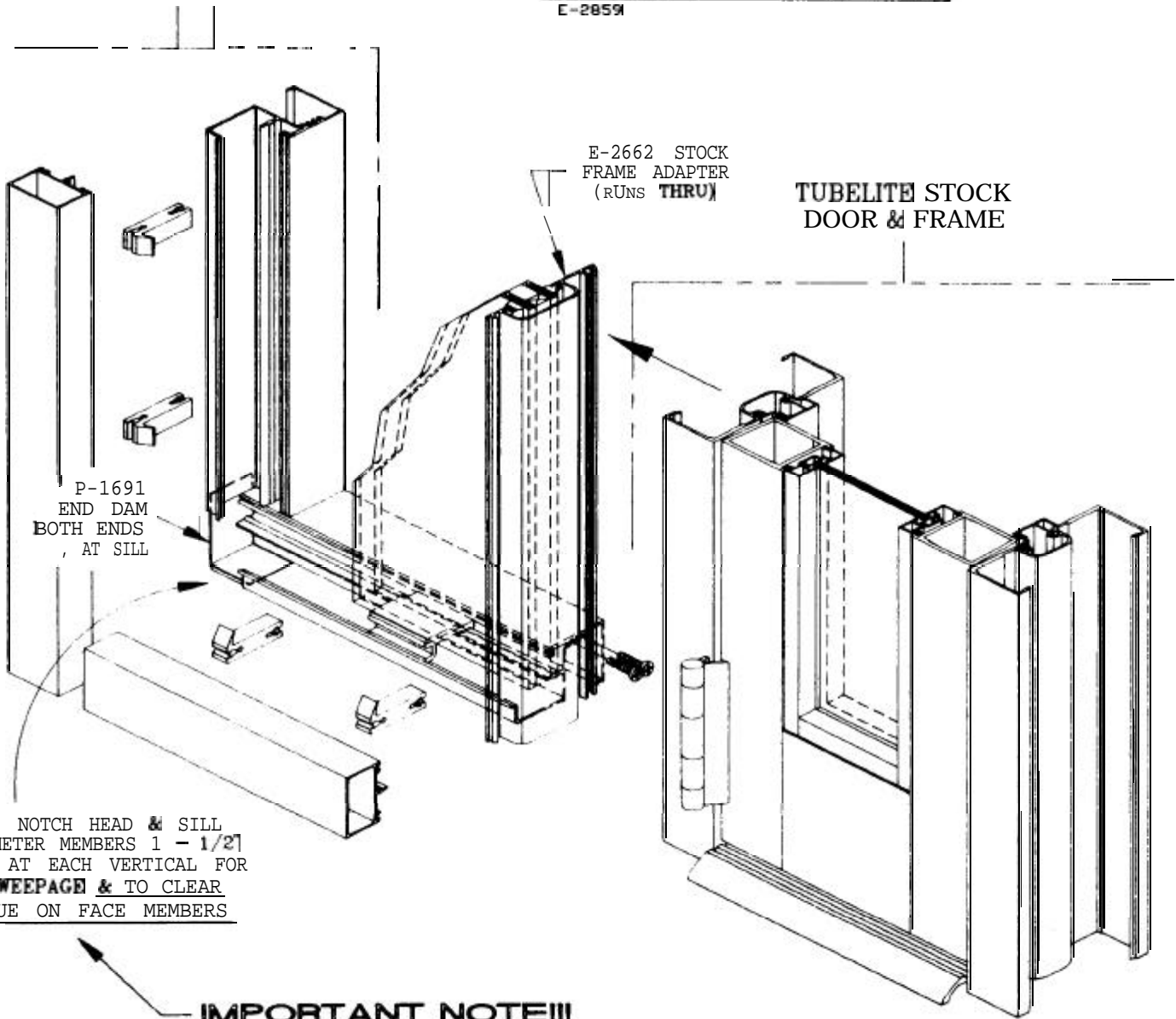

NOTE: NOTCH HEAD & SILL PERIMETER MEMBERS 1 - 1/2" WIDE AT EACH VERTICAL FOR WEEPAGE & TO CLEAR TONGUE ON FACE MEMBERS

**IMPORTANT NOTE!!!**

**TUBELITE** INSTALLATION INSTRUCTIONS  
FOR  
STOCK FRAMES & DOORS

1. Bottom of frame held in place with threshold clips. Head (and jamb if necessary) with screws under glazing or door stop.
2. Rock frame unit into opening. Be sure frame is plumb and square before anchoring.
  - A. Best procedure to hold unit for anchoring. is with the use of wood shingles wedged at the sides.
3. After unit is anchored and doors are hung (not glazed) be sure doors hang straight and in line with frame.
4. IMPORTANT! PROPER GLAZING AND BLOCKING OF GLASS!
  - A. Insert vinyl P1431 in all glass stops, leave vinyl extended  $\frac{1}{2}$ " each end and compress into member when installing. Install fixed glazing; horizontal & then vertical using raw hide mallet or wood block.
  - B. Place P484 in pre-punched holes per illustration.
  - C. Insert glass - snap in removable glass stop (E0410)
  - D. Close door to see that it is parallel with head jamb or transom bar. If door is sagging, turn the P465 adjustable setting block until door hangs properly.

PROPER BLOCKING OF GLASS WILL PREVENT SAGGING.

BE SURE TO FOLLOW INSTRUCTIONS FOR CLOSERS TO OBTAIN PROPER DOOR OPERATION. THESE INSTRUCTIONS ARE IN EACH CLOSER BOX.

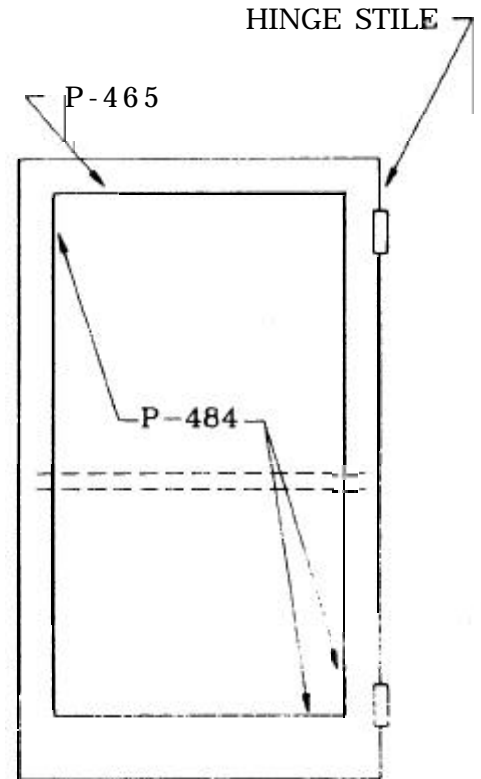
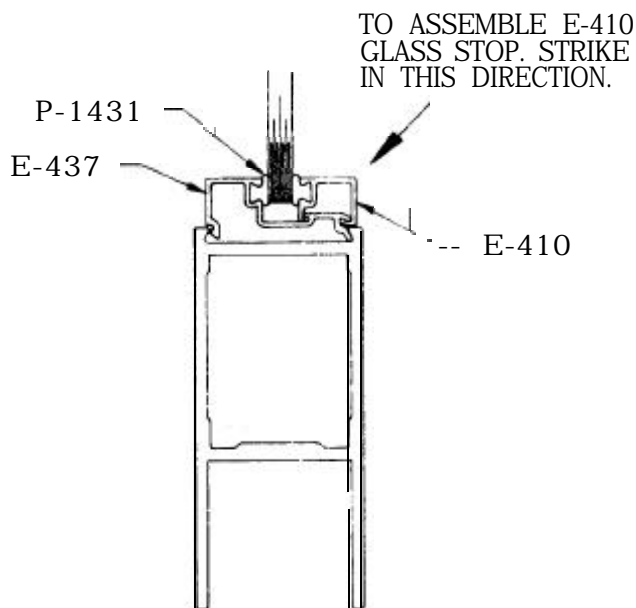

# THERMAL DOOR FRAME TYPICAL ASSEMBLY

## CENTER SET GLASS

E-288

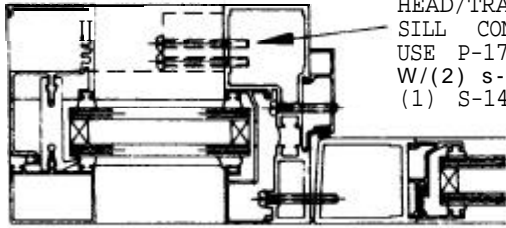

HEAD/TRANSOM &  
SILL CONNECTION  
USE P-1711 CLIP  
W/(2) S-009 &  
(1) S-146 SCREW

HEAD CONNECTION

TRANSOM CONNECTION  
USE ROLL-OVER MULLION

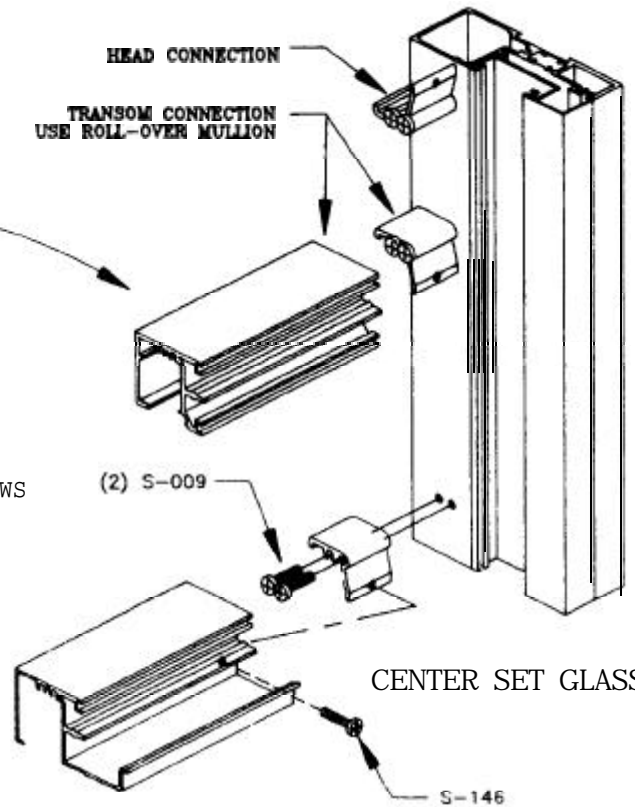

E-2858

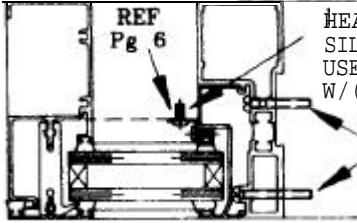

HEAD/TRANSOM &  
SILL CONNECTION  
USE P-1710 CLIP  
W/(4) S-196 SCREWS

S-009 HEADER/TRANSOM SCREWS

HEADER/TRANSOM CONNECTION  
IS SCREW BOSS JOINERY.

## FRONT LOADED GLASS

TYPICAL JAMB AT  
SILL ASSEMBLY  
(SEE PAGE 5)

CENTER SET GLASS

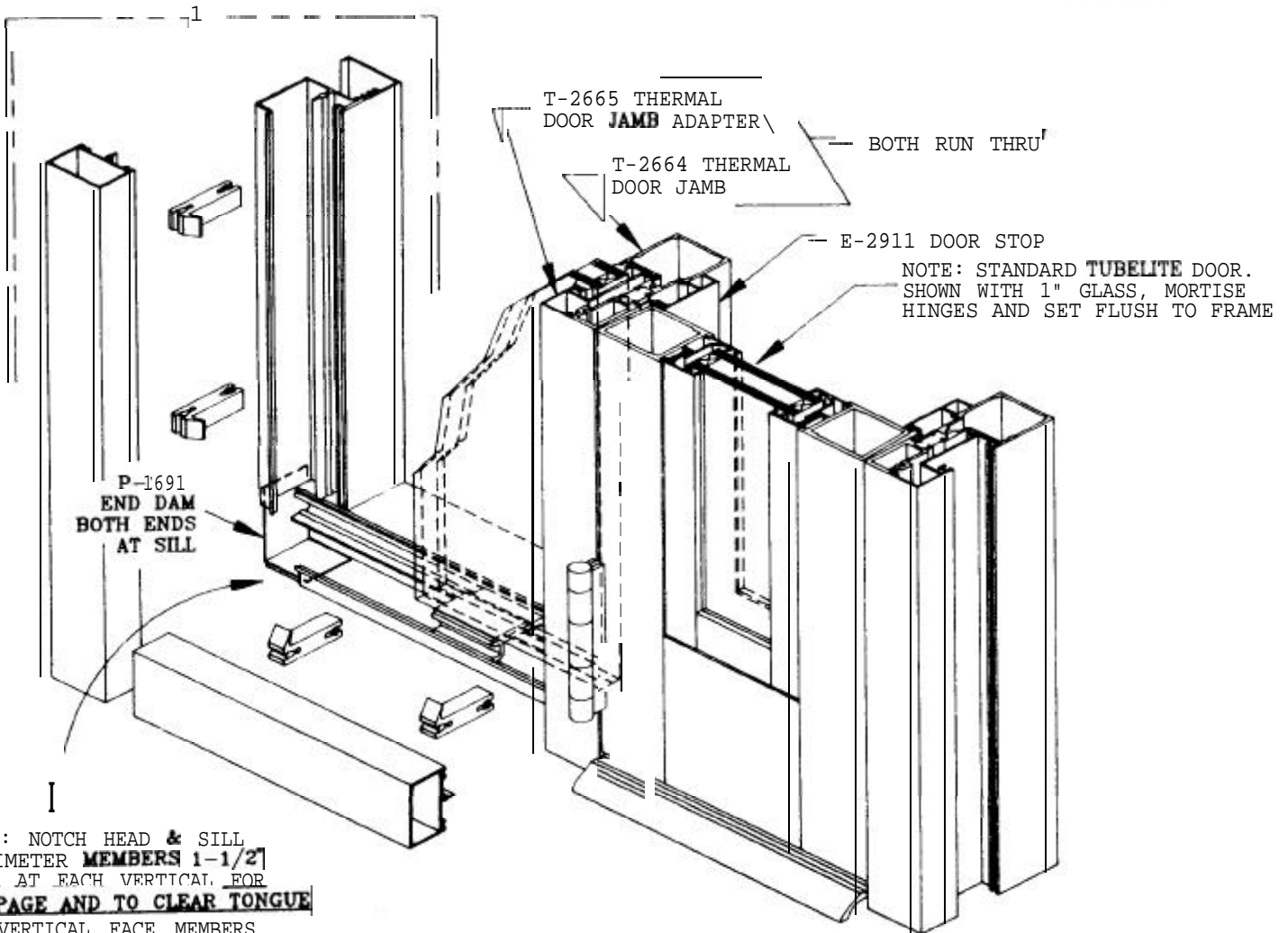

12

NOTE: NOTCH HEAD & SILL PERIMETER MEMBERS 1-1/2" WIDE AT EACH VERTICAL, FOR WEEPAGE AND TO CLEAR TONGUE ON VERTICAL FACE MEMBERS.

**IMPORTANT NOTE**

# THERMAL DOOR FRAME SIDELIGHT CLIP LOCATIONS (FOR CENTER SET GLASS)

T-2884 &  
T-2885

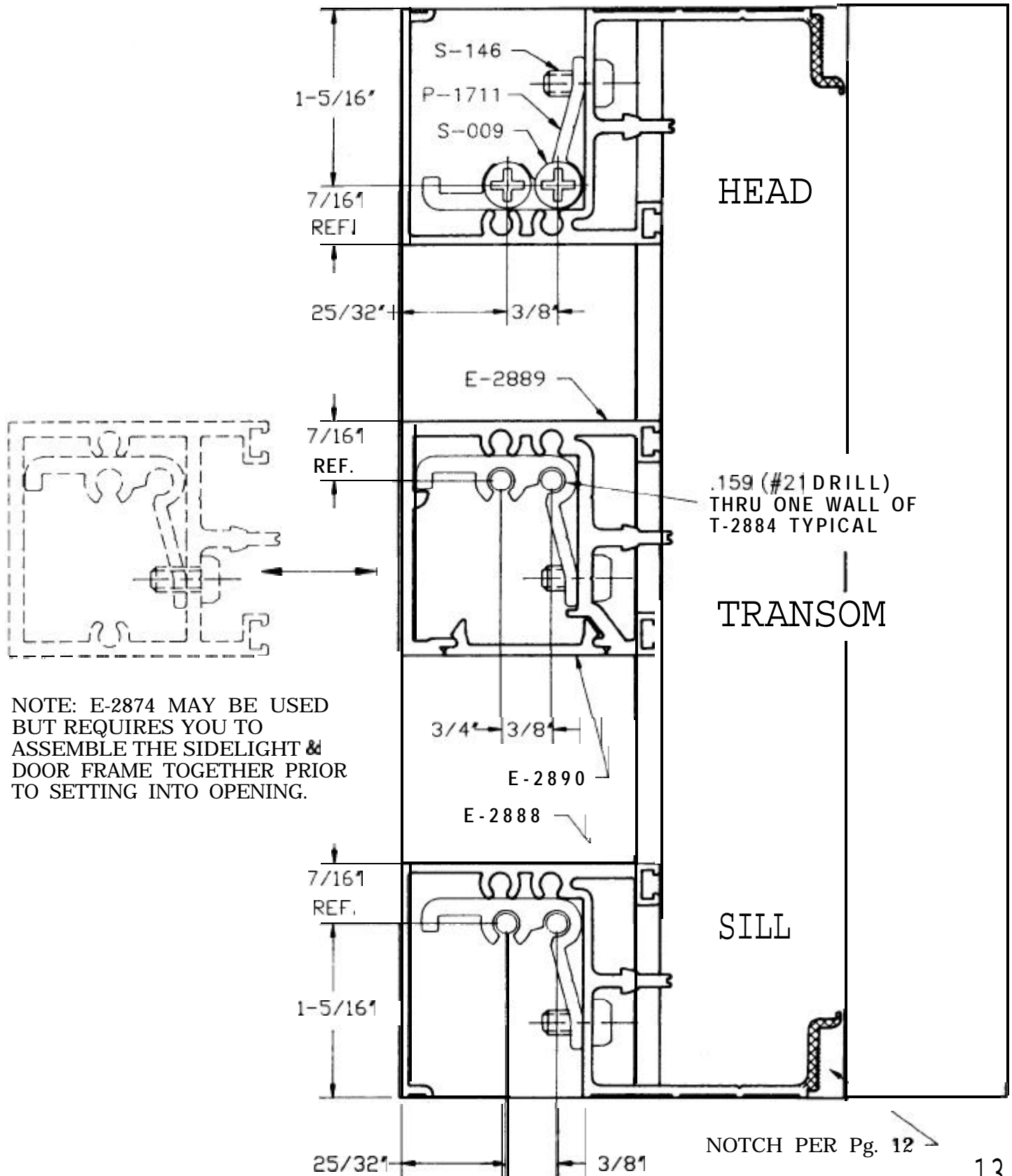

NOTE: E-2874 MAY BE USED  
BUT REQUIRES YOU TO  
ASSEMBLE THE SIDELIGHT &  
DOOR FRAME TOGETHER PRIOR  
TO SETTING INTO OPENING.

# THERMAL DOOR FRAME FABRICATION

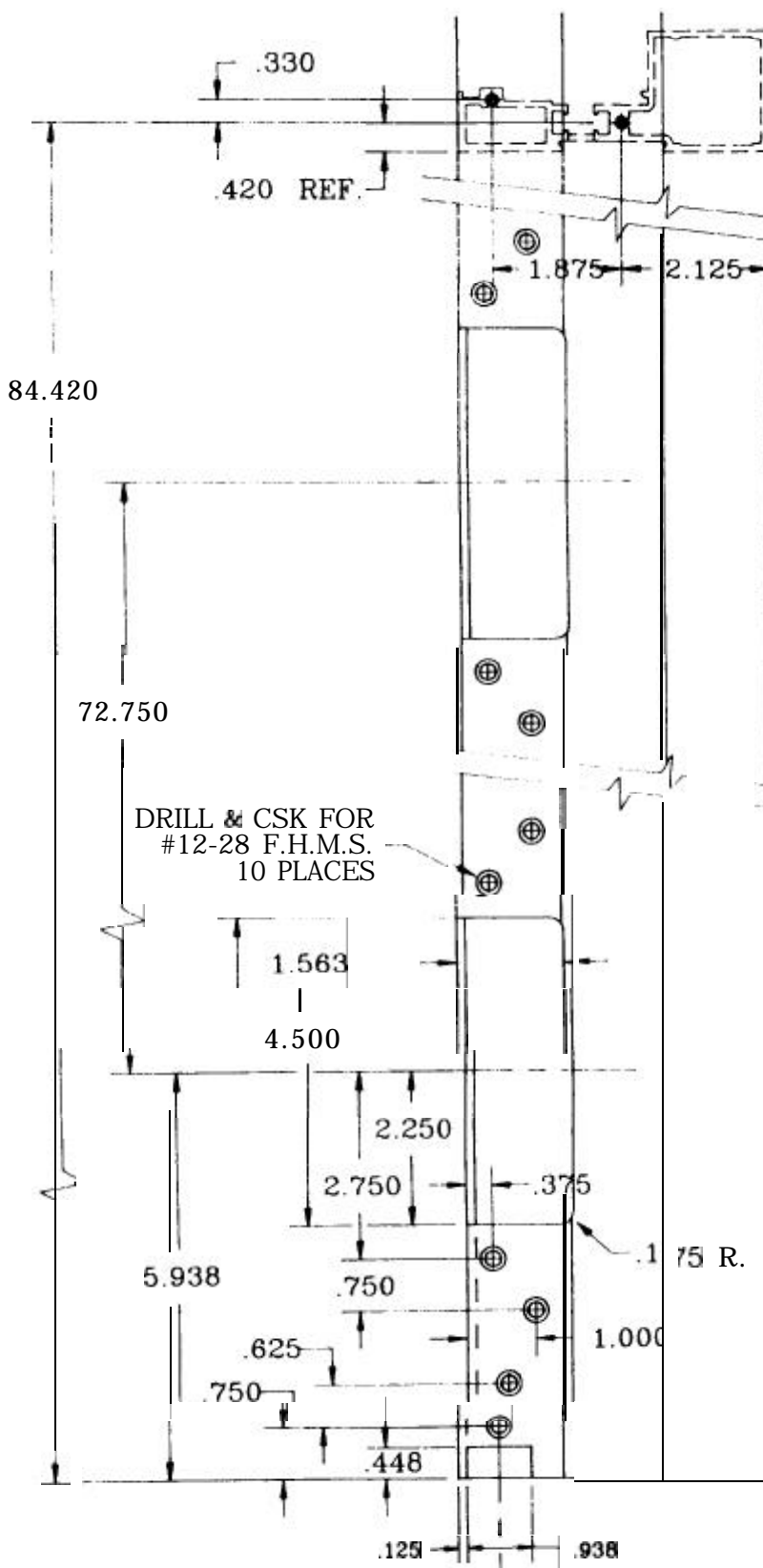

HEADER OR TRANSOM

NOTE: DOOR USES MORTISED BUTTS AND IS FLUSH TO THE EXTERIOR OF THE FRAME.

NOTE: REQUIRED PIECES FOR ASSEMBLY...  
 2 - P1218 BUTT PLATES  
 1 - P1422 SHORT THROW LOCK  
 2 - PO69 DOVETAIL FILLER  
 2 - PO92 HINGE FOR MORTISED DOOR AND FRAME.

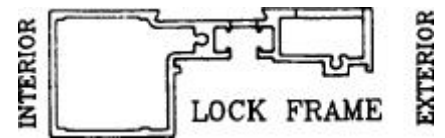
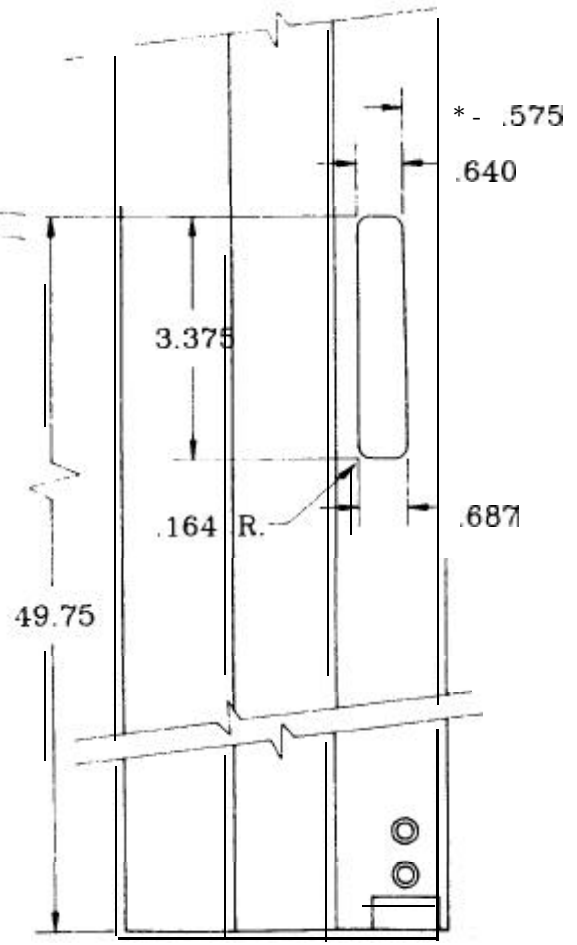

BOTTOM VIEW

BOTTOM VIEW

# Typical Horizontal Details

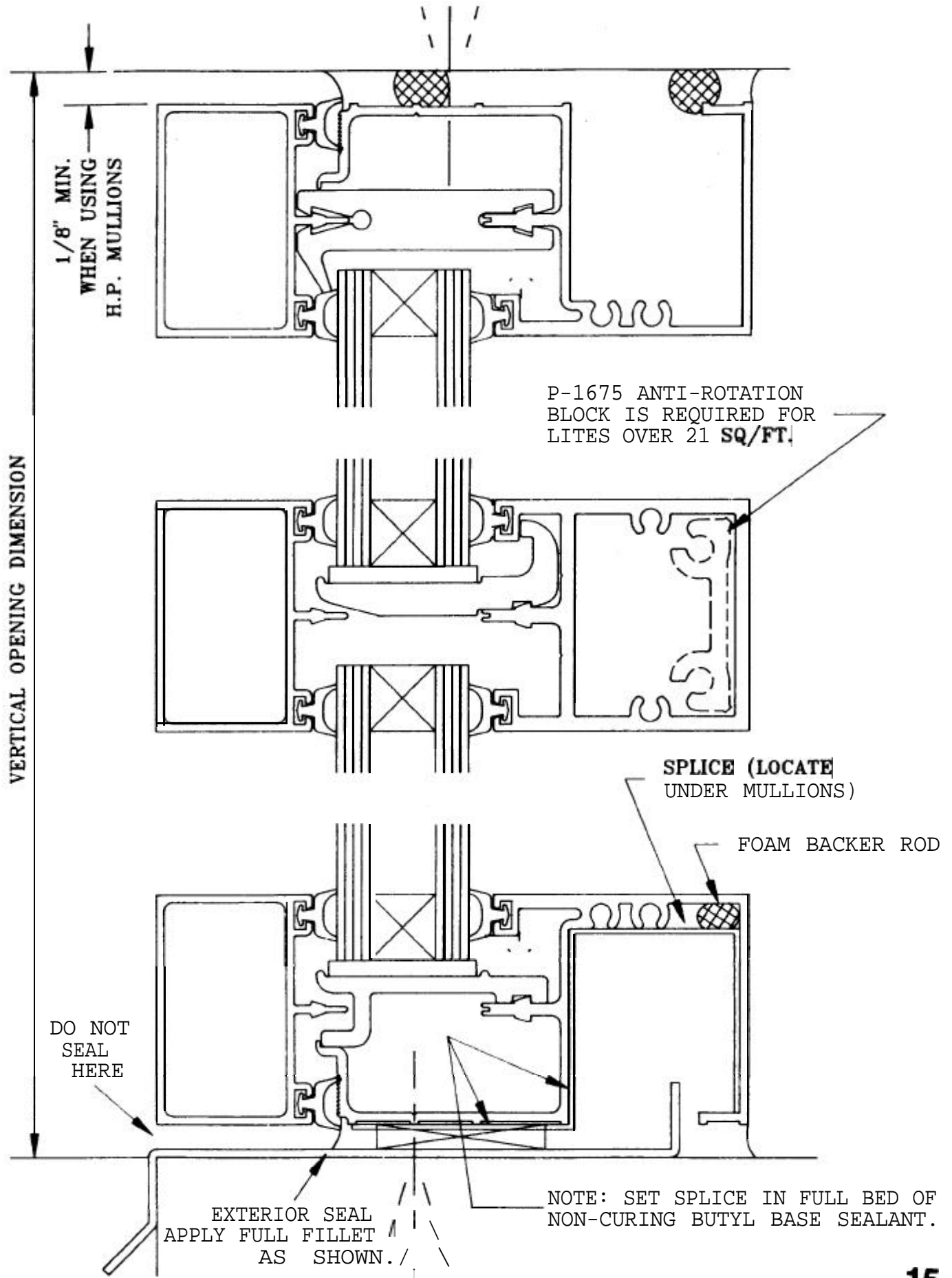

EXTERIOR SEAL  
APPLY FULL FILLET  
AS SHOWN.

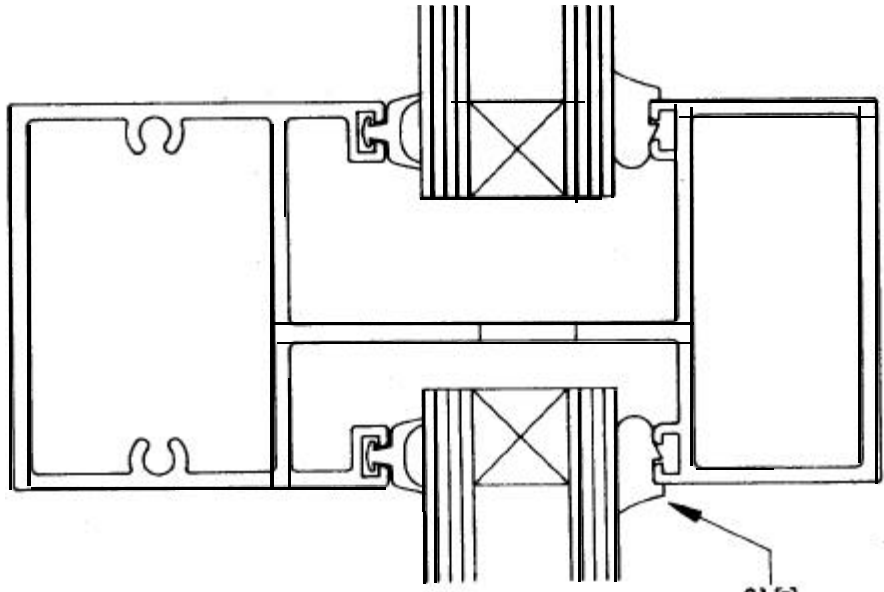
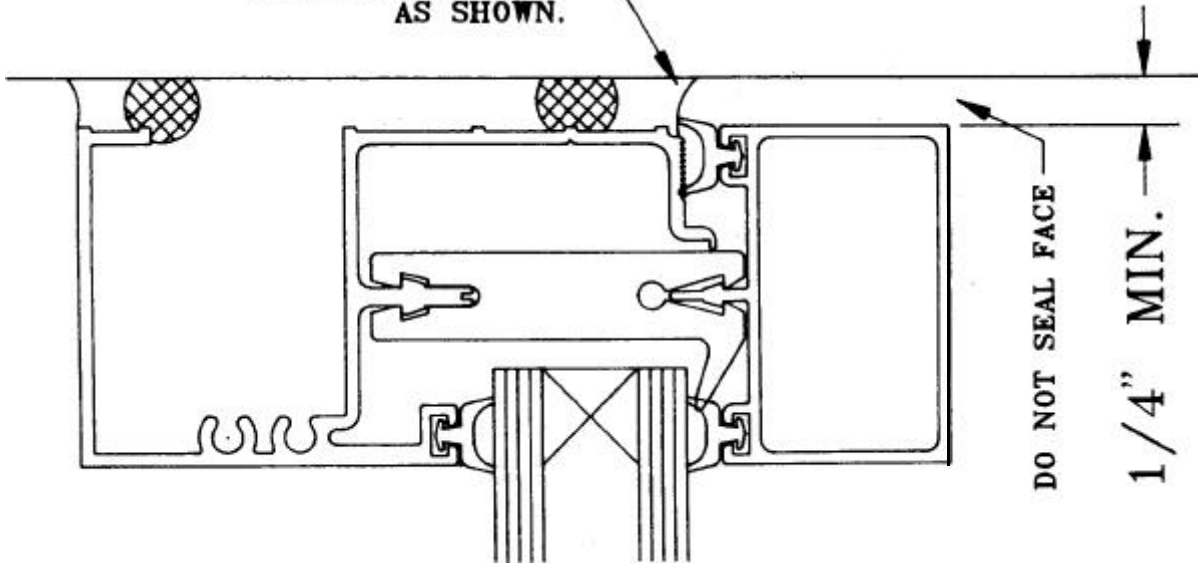

HIGH PERF.  
MULLION

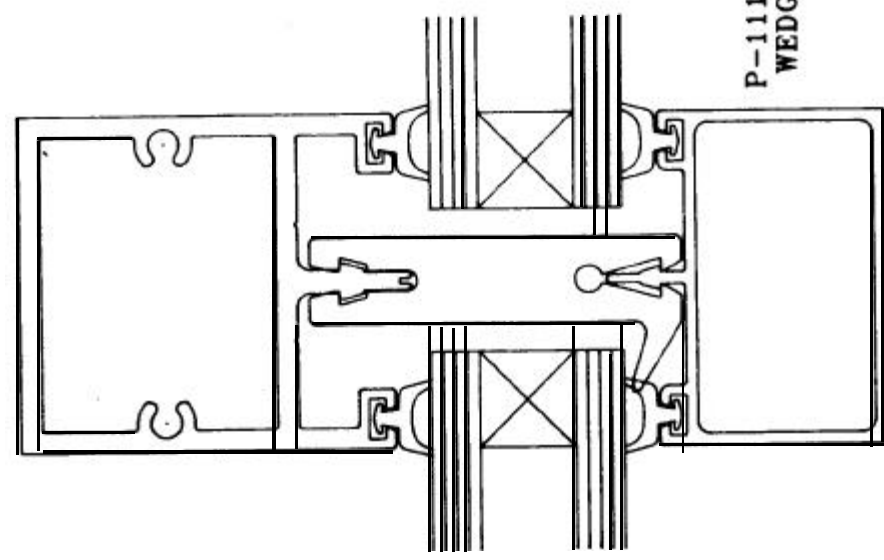

# Typical Vertical Details

# Glazing Combinations

1-3/4" SYSTEM

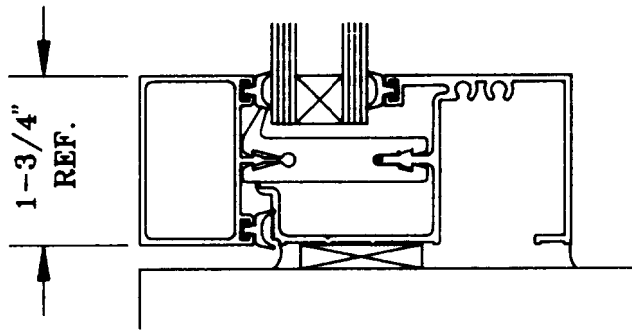

1-1/4" SYSTEM

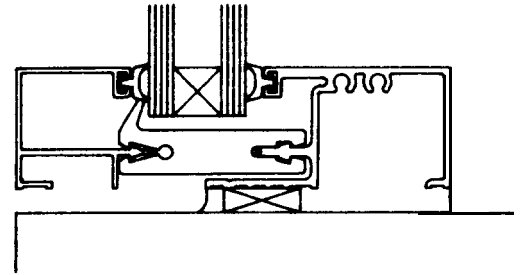

1" GLAZING

1/4" GLAZING

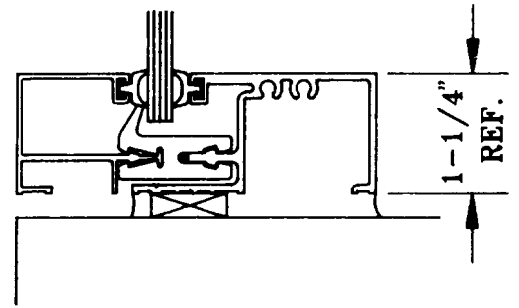
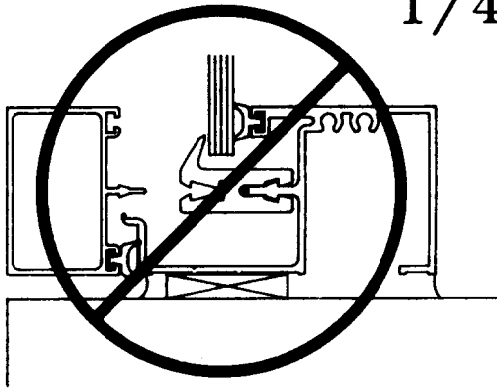

NOTE: THE P-1707 GLAZING CLIP IS NOT COMPATIBLE WITH 1-3/4" PERIMETERS (E-2858, E-2888 & E-2898). TO USE 1/4" INFILL WITH THESE MEMBERS YOU MUST USE THE P-1708 CLIP AND THE E-2867 REDUCER THROUGHOUT.

