

**NFRC U-FACTOR, SHGC, VT, &
CONDENSATION RESISTANCE
COMPUTER SIMULATION REPORT**

**Rendered to:
TUBELITE, INC.**

**SERIES/MODEL:
HW3700**

<i>Baseline Product for Validation Testing</i>	
Simulated Thermal Transmittance (U-Factor)	0.440
Unit Size:	59.00 inches wide by 23.63 inches high
Glazing Layer 1:	1/4" PPG Solarban 60 (e=0.035,#2)
Gap 1:	0.470 inch Technoform TGI Wave Spacer (TS-D) - 90% Argon Gas Fill
Glazing Layer 2:	1/4" Clear
Gap 2:	
Glazing Layer 3:	
Notes:	

Report Number: A4282.02-116-45
Report Date: 10/21/10
Expiration Date: 10/21/14

**NFRC U-FACTOR, SHGC, VT, & CONDENSATION RESISTANCE
COMPUTER SIMULATION REPORT**

Rendered to:
TUBELITE, INC.
4878 Mackinaw Trail
Reed City, Michigan 49677

Report Number: A4282.02-116-45
Simulation Date: 10/21/10
Report Date: 10/21/10
Expiration Date: 10/21/14

Project Summary:

Architectural Testing, Inc. was contracted to perform U-Factor, Solar Heat Gain Coefficient, Visible Transmittance, and Condensation Resistance* computer simulations in accordance with the National Fenestration Rating Council (NFRC). The products were evaluated in full compliance with NFRC requirements to the standards listed below.

**NFRC's Condensation Resistance rating is NOT equivalent to a Condensation Resistance Factor (CRF) determined in accordance with AAMA 1503.*

Standards:

NFRC 100-2010: Procedure for Determining Fenestration Product U-Factors
NFRC 200-2010: Procedure for Determining Fenestration Product Solar Heat Gain Coefficient and Visible Transmittance at Normal Incidence
NFRC 500-2010: Procedure for Determining Fenestration Product Condensation Resistance Values

Software:

Frame and Edge Modeling: THERM 5.2.14
Center-of-Glass Modeling: WINDOW 5.2.17
Total Product Calculations: WINDOW 5.2.17
Spectral Data Library: 17.5

Simulations Specimen Description:

Series/Model: HW3700
Type: Projected , Awning
Frame Material: AT Aluminum w/ Thermal Breaks - All Members
Sash Material: AT Aluminum w/ Thermal Breaks - All Members
Standard Size: 1500mm x 600mm

Technical Interpretations:

None

Modeling Assumptions:

- 1) To prevent air infiltration, tape was applied to all interior sash crack locations.

Specialty Products Table:

The specialty products method allow the manufacturer to determine the overall product SHGC and VT for any glazing option. The center of glass SHGC and/or VT must be determined using WINDOW 5.2. The method gives overall product SHGC and VT indexed on center of glass properties. All values used in the calculations are truncated to six decimal place precision.

	No Dividers	Dividers < 1	Dividers > 1
SHGC0	0.017296	0.019438	0.021474
SHGC1	0.700407	0.637058	0.576830
VT0	0.000000	0.000000	0.000000
VT1	0.683111	0.617621	0.555356

$$SHGC = SHGC0 + SHGCc (SHGC1 - SHGC0)$$

$$VT = VT0 + VTc (VT1 - VT0)$$

Validation Matrix:

The following products are part of a validation matrix. Only one is required for validation

<i>Product Line</i>	<i>Report Number</i>
None	-

Spacer Option Description

<i>Spacer Type</i>	<i>Sealant</i>		
	<i>Primary</i>	<i>Secondary</i>	<i>Desiccant</i>
Aluminum Spacer	Butyl Rubber	Butyl Rubber	Yes
Technoform TGI Wave Spacer	Polyisobutylene	Silicone	Yes

Grid Option Description

<i>Grid Size</i>	<i>Grid Type</i>	<i>Grid Pattern</i>
None	-	-

Reinforcement Option Description

<i>Location</i>	<i>Material</i>
None	-

Gas Filling Technique Description

<i>Fill Type</i>	<i>Method</i>
60.8% Argon	Single Probe Timed
62.4% Argon	Single Probe Timed
65% Argon	Single Probe Timed
74.7% Argon	Single Probe Timed
76.1% Argon	Single Probe Timed
81.7% Xenon	Single Probe Timed
83% Argon	Single Probe Timed
84.8% Xenon	Single Probe Timed
85.8% Argon	Single Probe Timed
86% Argon	Single Probe Timed
87.4% Argon	Single Probe Timed
88.7% Argon	Single Probe Timed

Edge-of-Glass Construction

<i>Interior Condition</i>	EPDM Gasket
<i>Exterior Condition</i>	Butyl tape

Weatherstripping

<i>Type</i>	<i>Quantity</i>	<i>Location</i>
Bulb gasket	2 rows	Sash perimeter

Frame/Sash Materials Finish

<i>Interior</i>	Painted Aluminum
<i>Exterior</i>	Painted Aluminum

**NFRC 100/200/500 Summary Sheet
HW3700**

ID	Pane Thickness 1	Gap Width 1	Pane Thickness 2	Gap Width 2	Pane Thickness 3	Gap Width 3	Pane Thickness 4	Gap Fill	Low-e (Surface#)	Tint	Spacer	Grid Type
	U-Factor			Solar Heat Gain Coefficient (SHGC) Grids (None / <1 / >=1)				Visible Transmittance (VT) Grids (None / <1 / >=1)			Condensation Resistance	
1	Center of Glass=0.4400											
	0.222	0.500	0.225					XEN84.48		CL	A1-D	N
	U-Factor 0.59			SHGC (N) 0.48				VT (N) 0.50			CR 33	
2	Center of Glass=0.4200											
	0.222	0.500	0.225					ARG76.09	0.652(#2)	GY	A1-D	N
	U-Factor 0.58			SHGC (N) 0.19				VT (N) 0.16			CR 34	
3	Center of Glass=0.4000											
	0.220	0.500	0.225					ARG85.82	0.566(#2)	GY	A1-D	N
	U-Factor 0.56			SHGC (N) 0.19				VT (N) 0.14			CR 34	
4	Center of Glass=0.3800											
	0.226	0.500	0.225					ARG83.03	0.471(#2)	AZ	A1-D	N
	U-Factor 0.55			SHGC (N) 0.14				VT (N) 0.11			CR 34	
5	Center of Glass=0.3600											
	0.220	0.500	0.225					ARG88.65	0.395(#2)	GY	A1-D	N
	U-Factor 0.54			SHGC (N) 0.11				VT (N) 0.05			CR 34	
6	Center of Glass=0.3400											
	0.232	0.500	0.225					ARG87.42	0.318(#2)	CL	A1-D	N
	U-Factor 0.53			SHGC (N) 0.33				VT (N) 0.39			CR 34	
7	Center of Glass=0.3200											
	0.223	0.500	0.225					ARG64.98	0.215(#2)	CL	A1-D	N
	U-Factor 0.51			SHGC (N) 0.44				VT (N) 0.50			CR 34	
8	Center of Glass=0.3000											
	0.233	0.500	0.225					ARG74.7	0.166(#2)	CL	A1-D	N
	U-Factor 0.50			SHGC (N) 0.32				VT (N) 0.36			CR 34	
9	Center of Glass=0.2800											
	0.223	0.500	0.225					ARG60.79	0.087(#2)	CL	A1-D	N
	U-Factor 0.49			SHGC (N) 0.39				VT (N) 0.52			CR 35	
10	Center of Glass=0.2600											
	0.223	0.500	0.225					ARG62.42	0.035(#2)	CL	A1-D	N
	U-Factor 0.48			SHGC (N) 0.28				VT (N) 0.48			CR 35	

**NFRC 100/200/500 Summary Sheet
HW3700**

ID	Pane Thickness 1	Gap Width 1	Pane Thickness 2	Gap Width 2	Pane Thickness 3	Gap Width 3	Pane Thickness 4	Gap Fill	Low-e (Surface#)	Tint	Spacer	Grid Type
	U-Factor			Solar Heat Gain Coefficient (SHGC) Grids (None / <1 / >=1)				Visible Transmittance (VT) Grids (None / <1 / >=1)			Condensation Resistance	
11	Center of Glass=0.2400											
	0.223	0.500	0.223					ARG86.02	0.035(#2) / 0.035(#3)	CL	A1-D	N
	U-Factor 0.46			SHGC (N) 0.26				VT (N) 0.43			CR	35
12	Center of Glass=0.2200											
	0.223	0.500	0.223					XEN81.67	0.018(#2) / 0.018(#3)	CL	A1-D	N
	U-Factor 0.45			SHGC (N) 0.19				VT (N) 0.36			CR	35

The Condensation Resistance results obtained from this procedure are for controlled laboratory conditions and do not include the effects of air movement through the specimen, solar radiation, and the thermal bridging that may occur due to the specific design and construction of the fenestration system opening.

Ratings values included in this report are for submittals to an NFRC-licensed IA and are not meant to be used directly for labeling purposes. Only those values identified on a valid Certification Authorization Report (CAR) by an NFRC accredited Inspection Agency (IA) are to be used for labeling purposes. The ratings values were rounded in accordance to NFRC 601, NFRC Unit and Measurement Policy.

Architectural Testing is an NFRC accredited simulation laboratory and all simulations were conducted in full compliance with NFRC approved procedures and specifications. The NFRC procedure requires that the computational results be verified through actual test results.

Detailed drawings, simulation data files, a copy of this report, or other pertinent project documentation will be retained by Architectural Testing, Inc. for a period of four years from the original test date. At the end of this retention period, such materials shall be discarded without notice and the service life of this report will expire. Results obtained are simulated values and were secured by using the designated test methods. This report does not constitute certification of this product nor an opinion or endorsement by this laboratory. It is the exclusive property of the client so named herein and relates only to the product simulated. This report may not be reproduced, except in full, without the written approval of Architectural Testing, Inc.

For ARCHITECTURAL TESTING, INC.:

SIMULATED BY:

REVIEWED BY:

Kevin S. Louder
Project Engineer

Kristen L. Livelsberger
Senior Simulation Technician
Simulator-In-Responsible-Charge

KSL:ksl
A4282.02-116-45

Attachments (pages): This report is complete only when all attachments listed are included.
Appendix A: Drawings and Bills of Material (7)

Revision Log

<u>Rev. #</u>	<u>Date</u>	<u>Page(s)</u>	<u>Revision(s)</u>
.02 R0	10/21/2010	All	Original Report Issue



All drawings and Bills of Material used to simulate this product are enclosed in this Appendix

Appendix A

A4282.02-116-45

ATI

Report # A4282-116-45

Date 10/18/10

Simulator *Ken Lamb*

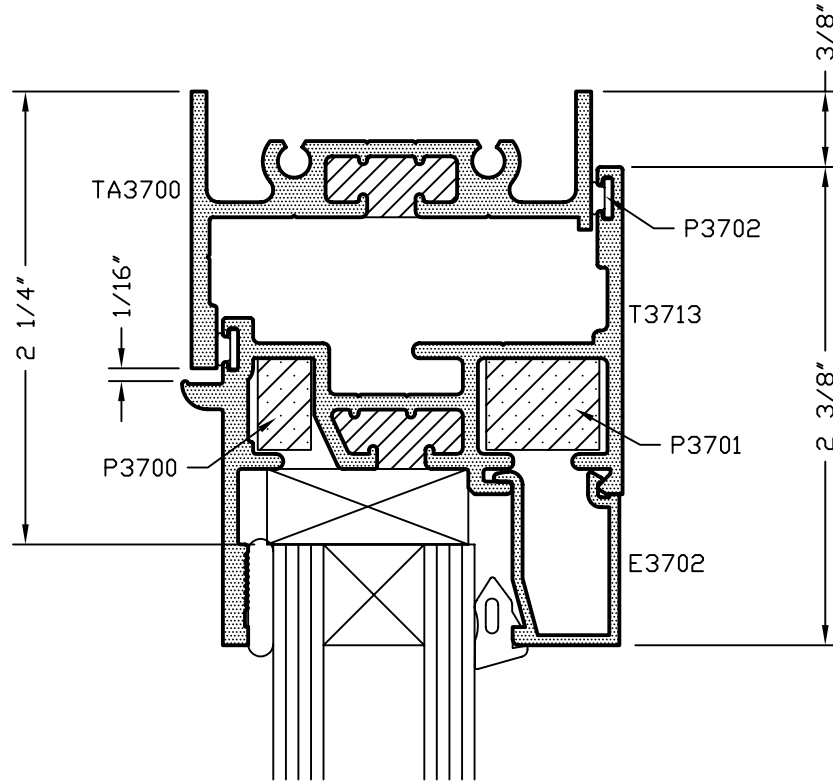

TUBELITE®
 STOREFRONT, CURTAINWALL & ENTRANCES
 DEPENDABLE

HW3700 HOPPER VENT WINDOW
 THERMAL PERFORMANCE TEST
 HEAD DETAIL

DRAWN BY JEM	DRWG DATE 10/08/10	APPV'D BY	DATE APPV'D	REV
DRWG SCALE 1"=1"	PRODUCT CODE 120	T962-1		

T962-2

ATI
 Report # A4282-116-45
 Date 10/18/10
 Simulator *Ken Lamb*

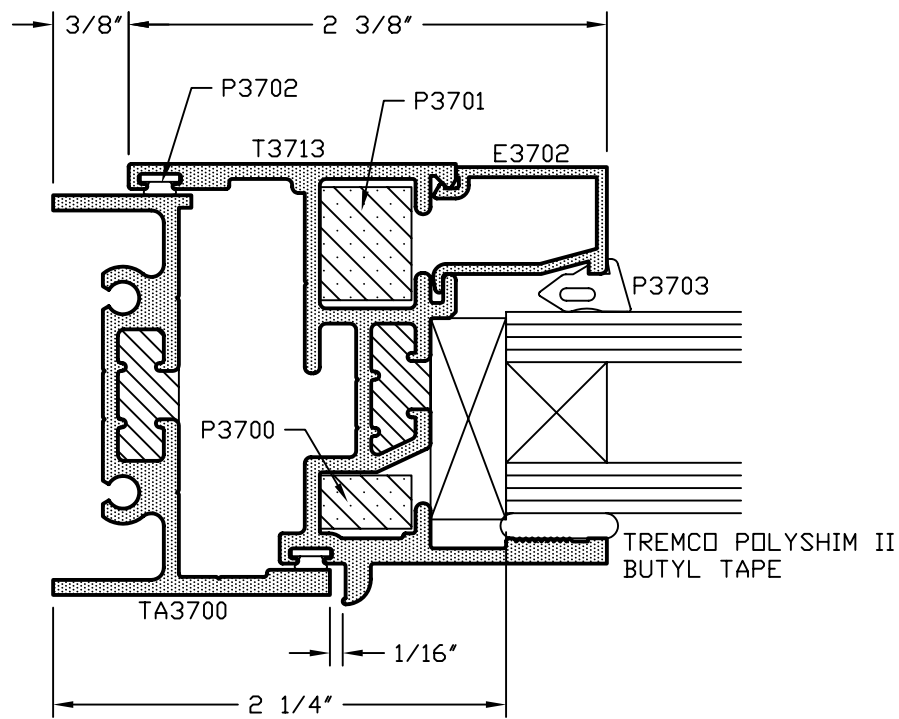

TUBELITE[®]
 STOREFRONT, CURTAINWALL & ENTRANCES
 DEPENDABLE

HW3700 HOPPER VENT WINDOW
 THERMAL PERFORMANCE TEST
 JAMB DETAIL

DRAWN BY JEM	DRWG DATE 10/08/10	APPV'D BY	DATE APPV'D	REV
DRWG SCALE 1"=1"	PRODUCT CODE 120	T962-2		

ATI

Report # A4282-116-45

Date 10/18/10

Simulator *Ken Lamb*

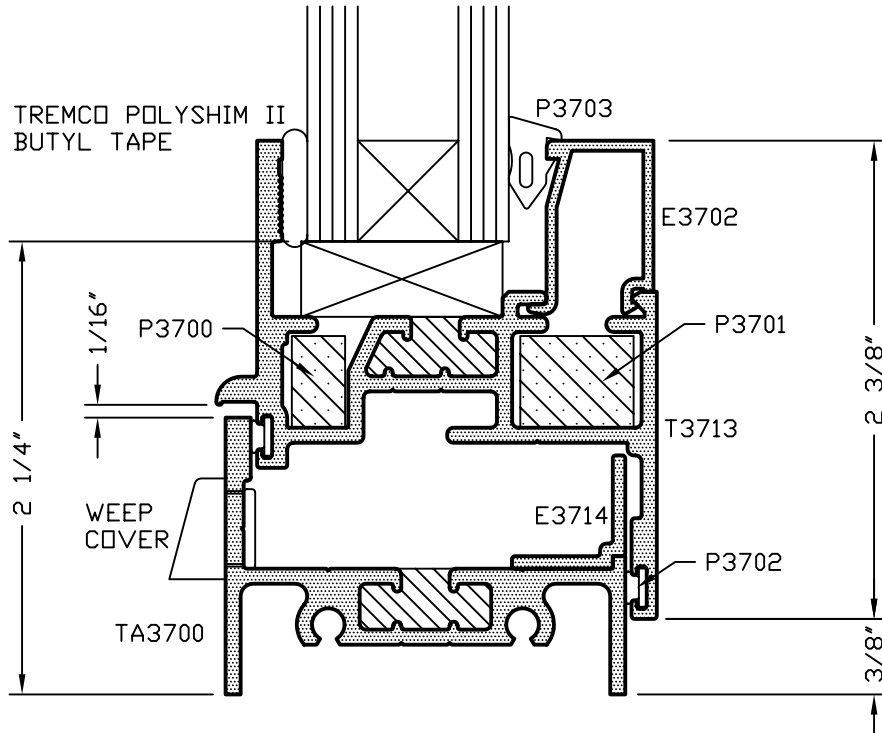

TUBELITE®
 STOREFRONT, CURTAINWALL & ENTRANCES
 DEPENDABLE

HW3700 HOPPER VENT WINDOW
 THERMAL PERFORMANCE TEST
 SILL DETAIL

DRAWN BY JEM	DRWG DATE 10/08/10	APPV'D BY	DATE APPV'D	REV
DRWG SCALE 1"=1"	PRODUCT CODE 120	T962-3		

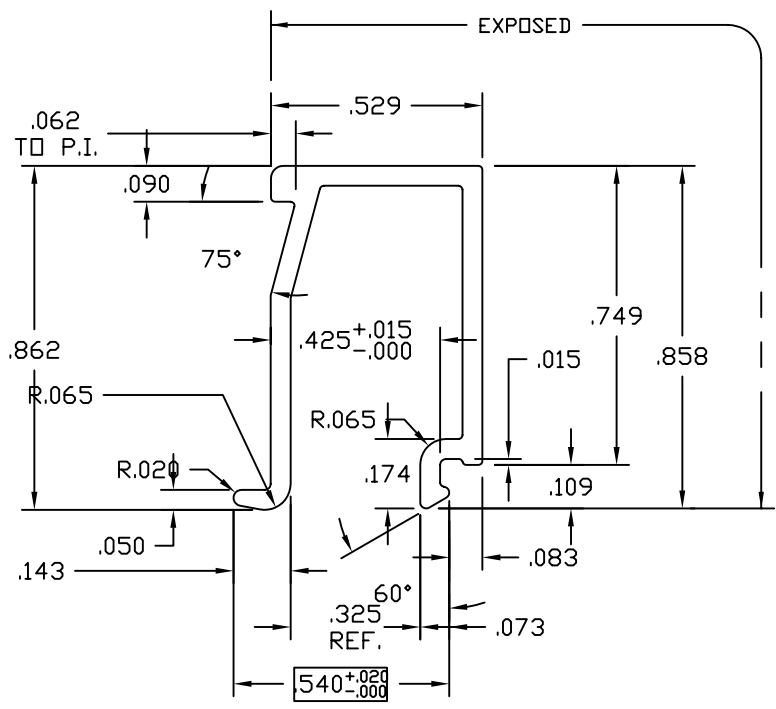

TWO TIMES SCALE

ATI

Report # A4282-116-45

Date 10/18/10

Simulator *Ken Lamb*

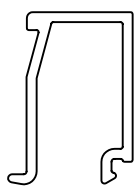

FULL SCALE

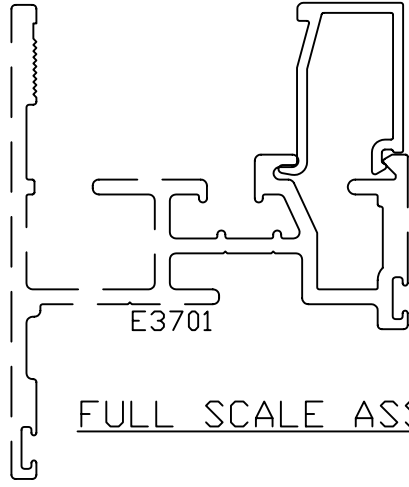

FULL SCALE ASSEMBLY

MATES WITH E3701

© 2006 TUBELITE INC. ALL RIGHTS RESERVED
 ALUMINUM ASSOCIATION STANDARD TOLERANCES APPLY UNLESS NOTED
 ALL UNSPECIFIED RADII .015
 * INDICATES .031 RADIUS

TUBELITE
 DEPENDABLE
 LEADERS IN ECO-EFFICIENT STOREFRONT, CURTAINWALL AND ENTRANCE SYSTEMS

3056 WALKER RIDGE NW, SUITE G
 WALKER, MICHIGAN 49544

WALL THK. .050	SECTION CLASS S	MAT'L 6063-T5	RATIO 464:1
PERIMETER OUT (TOTAL) 4.737	AREA .119	WGT/FT .140	
FACTOR 34	CIRCLE SIZE 1.043	INFILL VOLUME N/A	

RXX .215	SXX .020	IXX .006	CXX .351
RYY .286	SYX .026	IYY .010	CYY .490

GLASS STOP FOR 1" GLASS VENT WINDOWS

DENOTES CRITICAL DIMENSION
 ALL DIES PROPERTY OF TUBELITE

REV	DATE	DESCRIPTION	INTL
	08/25/00	RELEASE FOR TOOLING	CRH
	09/15/00	PART NUMBER WAS E9080001	CRH
	02/13/02	PART NUMBER WAS E908A01	SRD

DRAWN BY CRH	DRWG DATE 08/17/00	APPV'D BY	DATE APPV'D
DWG SCALE NOTED	PRODUCT CODE 120	E3702	
			REV

Aluminum Spacer

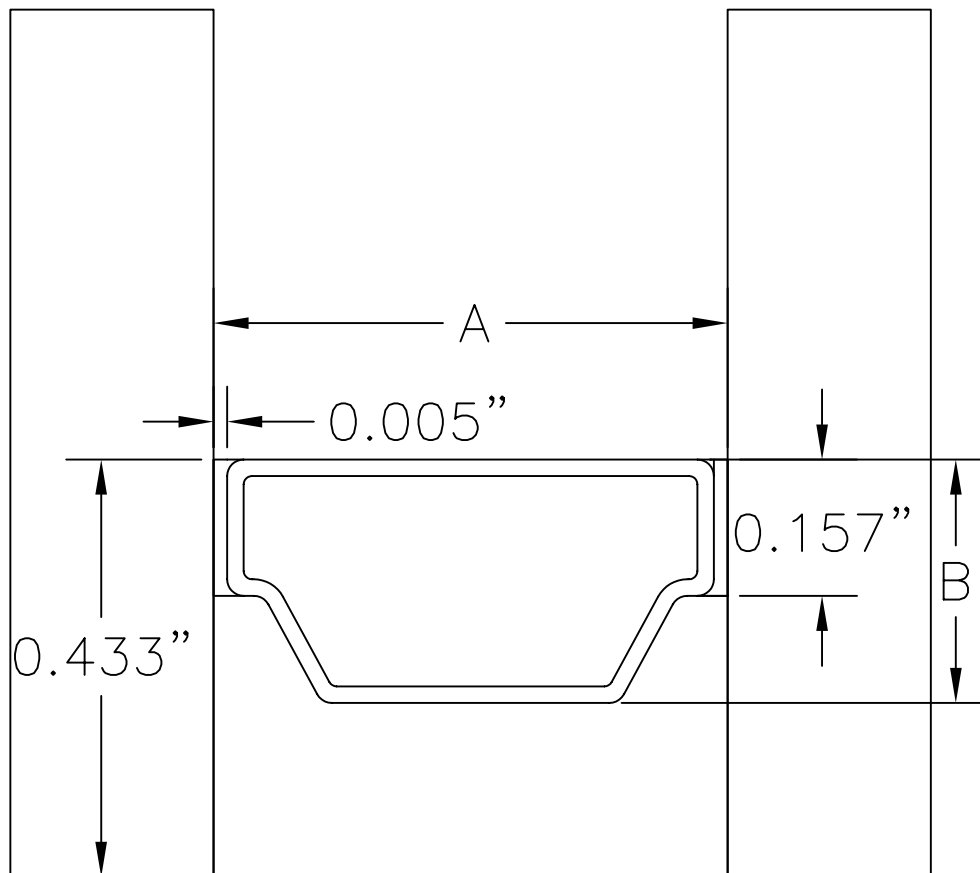

Finish Anodized
Offset: None
Primary Sealant: Butyl Rubber
Secondary Sealant: Butyl Rubber
Material: Aluminum
Width (A): 0.500
Height (B): 0.295
Wall Thickness: 0.016

ATI
Report # A4282-116-45
Date 10/18/10
Simulator Ken Land



Technoform Informational Bulletin

Master Part Chart List

Information Bulletin: 20060102PARTIB

Dated: 09/25/2007

Description: The current Technoform product line is listed in the following document. The products available include a nylon fixed corner key, a steel straight connector, a folding locking corner key and the Box and Wave I-SPACER™ (based on size). Additionally, in this document you will find the methodology for generating the part numbers to be used when ordering any of the products in our inventory.

Spacer Type	Spacer Width			Part Number			
	Fraction	Millimeters	Inches	Spacer	90° Keys	Folding Locking Key	Steel Connector
Box	7/32	5.56	0.2189	IS0732	CK0732F	NA	NA
Box	1/4	6.25	0.2461	IS0104	CK0104F	NA	SC0104S
Box	17/64	6.65	0.2618	IS1764	CK1764F	CK1764(1)	NA
Box	9/32	7.14	0.2811	IS0932	CK0932F	CK0932(1)	NA
Box	5/16	7.84	0.3087	IS0516	CK0516F	NA	SC0516S
Box	21/64	8.33	0.3300	IS2164	CK2164F	CK2164LK(1)	NA
Box	3/8	9.43	0.3713	IS0308	CK0308F	NA	SC0308S
Wave	13/32	10.22	0.4024	IS1332	CK1332F	CK1332LK	SC1332
Wave	7/16	11.01	0.4335	IS0716	CK0716F	NA	SC0716S
Wave	15/32	11.91	0.4689	IS1532	CK1532F	CK1532LK	SC1532S
Wave	1/2	12.60	0.4961	IS0102	CK0102F	NA	SC0102S
Wave	17/32	13.49	0.5272	IS1732	CK1732F	CK1732LK	SC1732S
Wave	9/16	14.19	0.5587	IS0916	CK0916F	NA	SC0916S
Wave	19/32	15.08	0.5937	IS1932	CK1932F	CL1932LK	SC1932S
Wave	5/8	15.87	0.6248	IS0508	CK0508F	NA	SC0508S
Wave	16/25	16.16	0.6362	IS1625	CK1625F	NA	SC1625S
Wave	21/32	16.67	0.6563	IS2132	CK2132F	CK2132LK	SC2132S
Wave	17/25	17.17	0.6760	IS1725	CK1725F	NA	SC1725S
Wave	23/32	18.26	0.7189	IS2332	CK2332F	CK2332LK	SC2332S
Wave	3/4	18.95	0.7461	IS0304	CK0304F	NA	SC0304S
Wave	25/32	19.74	0.7772	IS2532	CK2532F	CK2532LK	SC2532S

Nomenclature Rules: The following outlines the structure used to create part numbers.

Part Build → **Product** + **Size** + **Type** + **Color** = **Product ID**

Examples:

I-Spacer	IS	1532		LG	IS1532LG
Corner Key	CK	1532	F	--	CK1532F

Abbreviations:

IS	I-Spacer	LG	Light Gray	F	Fixed	S	Steel
CK	Corner Key	B	Black	LK	Folding Locking	P	Plastic
SC	Straight Connector	W	White				
		BR	Bronze				

Spacer width is the actual width as measured across the top of the thermoplastic blend.

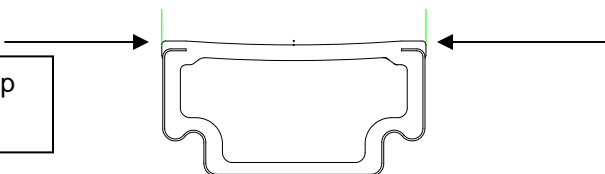

Technoform North America
 1755 Enterprise Parkway, Suite 300
 Helpline: 330.487.6600
 www.technoform.us

ATI

Report # A4282-116-45

Date 10/18/10

Simulator *Ken Lind*

